

Grantham Floods Commission of Inquiry

Report

October 2015

Grantham Floods Commission of Inquiry

www.granthaminquiry.qld.gov.au

© Grantham Floods Commission of Inquiry 2015

The Grantham Floods Commission of Inquiry supports and encourages the dissemination and exchange of information. However, copyright protects material in this report. The Commission has no objection to this material being reproduced but asserts its right to be recognised as author of its original material and the right to have its material remain unaltered.

Grantham Floods Commission of Inquiry

7 October 2015

The Honourable Anastacia Palaszczuk MP
Premier and Minister for the Arts
PO Box 15185
CITY EAST QLD 4002

Dear Premier

In accordance with Commissions of Inquiry Order (No 3) 2015, I present the report of the Grantham Floods Commission of Inquiry.

Yours sincerely



Walter Sofronoff QC
Commissioner
Grantham Floods Commission of Inquiry

Table of Contents

Chapter 1: What happened on 10 January 2011?	1
Chapter 2: What now?	43
Chapter 3: Was the flooding “unprecedented”?	47
History of Grantham and the railway line.....	47
Chapter 4: The landscape and its history	53
The Lockyer Valley	53
The Grantham sand plant	54
History of the sand plant.....	54
Terms of Reference and the eastern bund.....	55
History of the bunds	56
The conditions of approval	61
Chapter 5: What caused the Grantham flood	64
The rain on 10 January 2011.....	64
The flooding on 11 January 2011	66
The nature of the flooding of Grantham and its surrounds on 10 January 2011	66
Expert investigations	70
Assistance of experts and the use of computer modelling	70
Why the flooding of Grantham happened in the way that it did.....	71
The effect of the bunds before they were overtopped.....	71
The effect of the bunds being overtopped and eroded	72
The cause of the western overbank flow	76
The cause of the south-western overbank flow.....	80
The effect of the railway line.....	80
The effect of the Grantham quarry on evacuation	82
The effect of the quarry on damage to property	82
Cause of the flooding of Grantham	86
Conclusion	88
Chapter 6: The initial investigation and how eyewitness accounts were dealt with	91
Establishment of Taskforce Galaxy and scope of the investigation	91
Taskforce Galaxy’s investigation.....	92
The handling of evidence by Taskforce Galaxy	92
The exclusion zone at Grantham.....	94
Ability of Mr Daniel McGuire to contact friends, relatives or the media immediately after 10 January 2011	96

Treatment of Grantham residents by Queensland Police Service officers.....	96
A final consideration.....	100
Appendix A: Expert reports – geotechnical advice.....	101
Mr Starr’s qualifications and experience.....	101
Scope of work performed by Mr Starr.....	101
Starr main report	101
Starr first supplementary report.....	101
Starr second supplementary report	102
Methodology used by Mr Starr to make his findings	102
LiDAR surveys.....	102
Aerial photography.....	102
Satellite images	103
Photographs and plans provided in witness statements and submissions.....	103
Site inspections	103
Opinions expressed in Starr main report.....	104
Assessment of pre-quarry terrain.....	104
Assessment of the nature of the bunds surrounding the Grantham quarry	106
Assessment of the method of construction of the bunds surrounding the Grantham Quarry.....	107
Assessment of the timing of construction of the bunds surrounding the Grantham Quarry.....	107
Opinion as to the broken pole	114
Overall conclusions expressed in Starr second supplementary report.....	115
Issues raised regarding Mr Starr’s findings.....	116
The likely height of the western embankment as at January 2011.....	116
The likely period over which the bunds were constructed	118
Reliability of Mr Starr’s opinion.....	119
Appendix B: Expert advice – Investigation of failed timber utility pole.....	121
Mr MacKenzie’s qualifications and experience.....	121
Scope of work performed by Mr MacKenzie	121
Key information relied on by Mr MacKenzie.....	121
Location and properties of the broken pole.....	122
Location of the broken pole	122
Properties of the broken pole.....	122
Assessment of likely causes of failure of the broken pole	123
Reliability of Mr MacKenzie’s opinion.....	124

Appendix C: Expert reports – hydrological reports	125
Evidence of Dr John Macintosh.....	125
Scope of work performed by Dr Macintosh.....	125
Terminology adopted by Dr Macintosh.....	125
Key Information relied upon by Dr Macintosh.....	126
Setup of Dr Macintosh’s GFCOI Model	127
The LVRC Models	127
Suitability of the LVRC Models.....	127
Adaptation of the LVRC Models.....	128
Corroboration of Dr Macintosh’s GFCOI Model	138
Corroboration to eyewitness accounts	138
Corroboration to peak survey levels.....	140
Dr Macintosh’s assessment of the chronology of the January 2011 flood in Grantham	140
Dr Macintosh’s assessment of the impact of the Grantham quarry	152
Grantham quarry model scenarios	152
Assessment of the Grantham quarry scenarios.....	156
Assessment of impact on evacuation.....	165
Dr Macintosh’s assessment of the impact of the railway embankment.....	166
No railway embankment scenarios.....	166
Assessment of railway embankment scenarios.....	168
Overall conclusions reached by Dr Macintosh.....	171
Evidence of Mr Stefan Szykarski	171
Szykarski report to the Commission	172
Issues considered by Mr Szykarski.....	172
Mr Szykarski’s opinion as to the flooding in Grantham.....	173
Evidence of Dr David Newton	174
Scope of work performed by Dr Newton.....	174
Key Information relied upon by Dr Newton.....	175
Preparation of Dr Newton’s Model	176
Validation of Dr Newton’s Model.....	181
Dr Newton’s assessment of the impact of the Grantham Quarry.....	185
Summary of Conclusions reached by expert hydrologists.....	189
Issues raised regarding the hydraulic modelling	190
Submissions by parties with leave to appear	190
Conclusions regarding issues raised by parties with leave to appear	195

Submissions by interested persons without leave to appear	195
Appendix D: Expert advice Hazard of flood waters	209
Mr Smith’s qualifications and experience.....	209
Scope of work performed by Mr Smith.....	209
Velocity of floodwaters	209
The hazardous nature of floodwaters	210
Mr Smith’s opinion as to the effect of the 10 January 2011 flood on people, vehicles and buildings.....	211
Reliability of Mr Smith’s opinion.....	212
Use of Mr Smith’s opinion to understand other flooding effects	212
Appendix E: Matters outside the terms of reference	215
The allegation the State refused offers of assistance from the Australian Defence Force to deploy Blackhawk helicopters to rescue Grantham residents.....	215
The claim there were more missing and deceased people than were reported to the State Coroner.....	216
Allegations about property damage caused during searches of Grantham after 10 January 2011	217
The claim that on the day of the flood 000 received a call warning about a wall of water heading to Grantham but that it was disregarded by the State Disaster Coordination Centre	217
The timing of the State Emergency Service response to flooding in Grantham on 10 January 2011	218
The claim about removal of Acting Senior Sergeant Bernie Wilce from the Local Disaster Management Group immediately after the floods.....	218
Appendix F: Terms of Reference	221
Appendix G: Specific findings with respect to the Terms of Reference	223
Appendix H: Expert reports	224
Appendix I: Parties granted leave to appear.....	225
Appendix J: Exhibits, witnesses, public submissions and statements	226
Exhibits	226
Witness appearances.....	226
Public Submissions	227
Statements	228
Appendix K: Commission staff.....	231
Appendix L: Glossary of terms	232
Nomenclature	236

Chapter 1: what happened on 10 January 2011?

1. The second half of 2010 was the wettest period July to December on record in Australia. In Queensland, December saw the greatest rainfall ever.
2. The township of Grantham is in the Lockyer Valley in Queensland between Brisbane and Toowoomba. In 2001 it had a population of about 500 people. Lockyer Creek runs past it. On its eastern end Sandy Creek joins Lockyer Creek.



3. Because Grantham is situated in a low-lying area between these two creeks it floods periodically. These floods are, on the whole, harmless. At least, the people of Grantham have grown used to them. They can predict their occurrence in good time and they make preparations accordingly. These floods happen because when it rains heavily upstream of Grantham, Lockyer Creek rises and causes Sandy Creek to back up so that it breaks its banks. The waters of Sandy Creek slowly rise to flood the eastern side of Grantham and low-lying areas of the western side of Grantham, closest to the creek. This rise of water is slow and predictable. The Lockyer Creek itself does not break its banks.
4. December 2010 and the early part of January 2011 saw floods of just this kind. As usual, not all houses in Grantham were affected. But those people who expected flooding on their properties moved their vehicles to nearby high ground which is owned by Queensland Rail and moved valuable articles in their houses to high points. As more than one witness at the public hearings explained to me, such floods were also a kind of social event for some who would gather together and have a few drinks on someone's veranda and watch the waters rise and then recede.
5. In December 2010 and January 2011 Daniel McGuire was living at Grantham on Gatton-Helidon Road with his wife Llync Clarke-Jibson and their children, Garry who was 12, Zachary who was seven, and Jocelyn who was six. He and his family had moved to Grantham in 2006 from Canungra. Mr McGuire was an experienced Rural Fire Brigade member. He had been a volunteer Rural Fire Fighter for almost a quarter of a century. He had first joined the Rurals, as they are called, in St George; after moving to New South Wales he joined that State's Rurals and was a member there for about another 15 years. Then he moved to Canungra in Queensland in 1999 where he joined the Rurals again. As he has explained, when you move locations, your membership of the Rurals must be renewed with the local Brigade. Upon moving to Grantham, in accordance with this practice, he reapplied and joined the

Grantham Rural Fire Brigade. His wife, Ms Clarke-Jibson was also a member of the Rurals. In addition, both of them had been trained in swift water rescue when they were members of the Rurals in New South Wales.

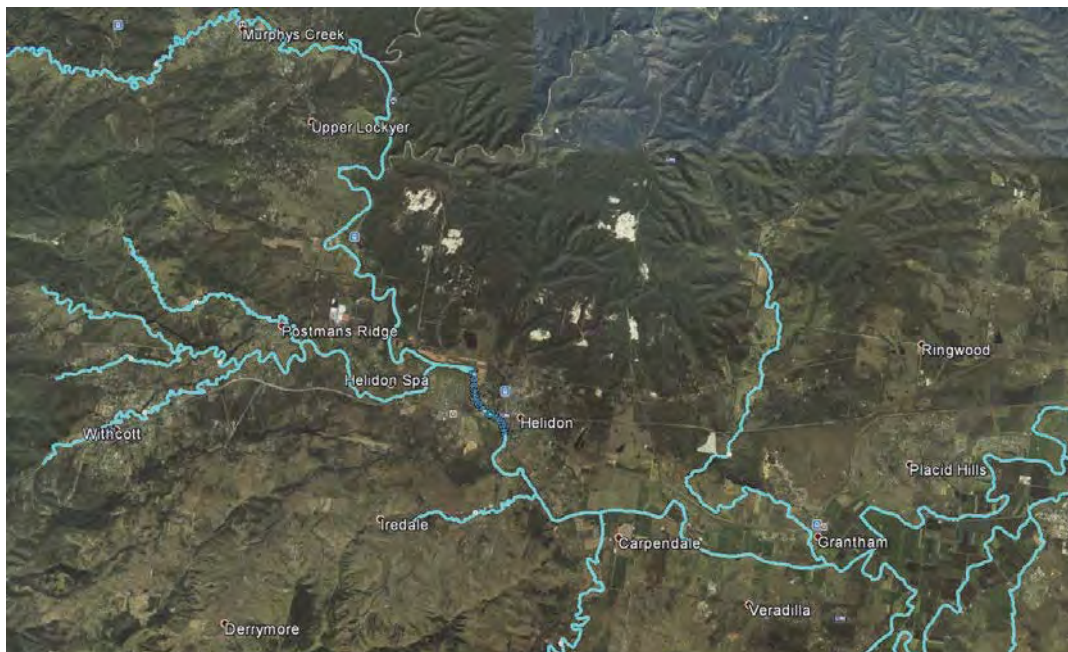

6. Between 2006, when Mr McGuire arrived in Grantham with his family, and until 2010, Grantham had not experienced any flooding of the kind I have described. So the flooding in December 2010 was new to Mr McGuire although it was familiar to long-time residents of Grantham. It rained steadily during December. On Christmas Day Sandy Creek overflowed in the afternoon in its usual way and the floodwaters then receded a few hours later. The overflow from the creek flooded Mr McGuire's property. On the next day Sandy Creek flooded again and once more Mr McGuire's property as well as others in the town were inundated. The water came into his yard from the east and flowed south out to the table drain outside his property from where it re-entered Sandy Creek.
7. This pattern repeated itself in early January although on 2 January 2011 Mr McGuire noticed that the floodwaters were higher than previously so that parts of Gatton-Helidon Road, Harris Street and Railway Street had water over them.
8. Mr McGuire operated a first aid and heavy vehicle recovery business. For that purpose he had acquired some "Road Closed" and "Water Over Road" signs. Of his own initiative he put up these signs outside his house and stayed with them to alert road users. He advised his superior at the Rurals that he had done this. He also advised the police in Helidon of the situation in Grantham and what he had done.
9. This was the start of a busy period for Mr McGuire. When the water went down at around lunchtime on 2 January, Mr McGuire removed the signs and, together with other members of the Rurals, assisted in filling sandbags at the Council depot at Gatton. He delivered these to residents in Grantham.
10. Late on the afternoon of 2 January, Sandy Creek flooded again and this time the water depth at the eastern end of the town was about three feet and Mr McGuire put his signs up again. He was then asked by the Rurals to deliver some insulin to a resident on Gatton-Helidon Road. Because he carried this drug as part of his paramedic equipment, he was able to do this promptly. Late that afternoon he took one of the Rurals' trucks, an Isuzu 4WD called "Grantham 51", to Gatton to pick up his supervisor and a senior fire officer to bring them to Grantham so that they could see the situation for themselves. When he returned home the waters were still high and he and Ms Clarke-Jibson stayed up for most of the night to man the road closure signs and to keep an eye on the floodwaters.

On the other side of the floodwaters, Gatton police were performing a similar task. There was also a police station at Helidon, which is a town about 10 kilometres west of Grantham. But Grantham was too small to justify a police station of its own. So, Mr McGuire found himself performing these tasks.

11. By mid-morning of the next day the road was clear of water and Mr McGuire and his wife took the signs down. However, they had been warned by the Rurals that much more rain was expected and, indeed, Sandy Creek again flooded in the afternoon. Again he and his wife blocked the road outside their house and, again, Mr McGuire rang Helidon police to inform them of the situation and what he had done. I should observe that the police officer at Helidon was on his own and was performing his own duties and was not in a position also to attend to these tasks in Grantham so, if Mr McGuire and Ms Clarke-Jibson had not performed these tasks, they would have been left undone.

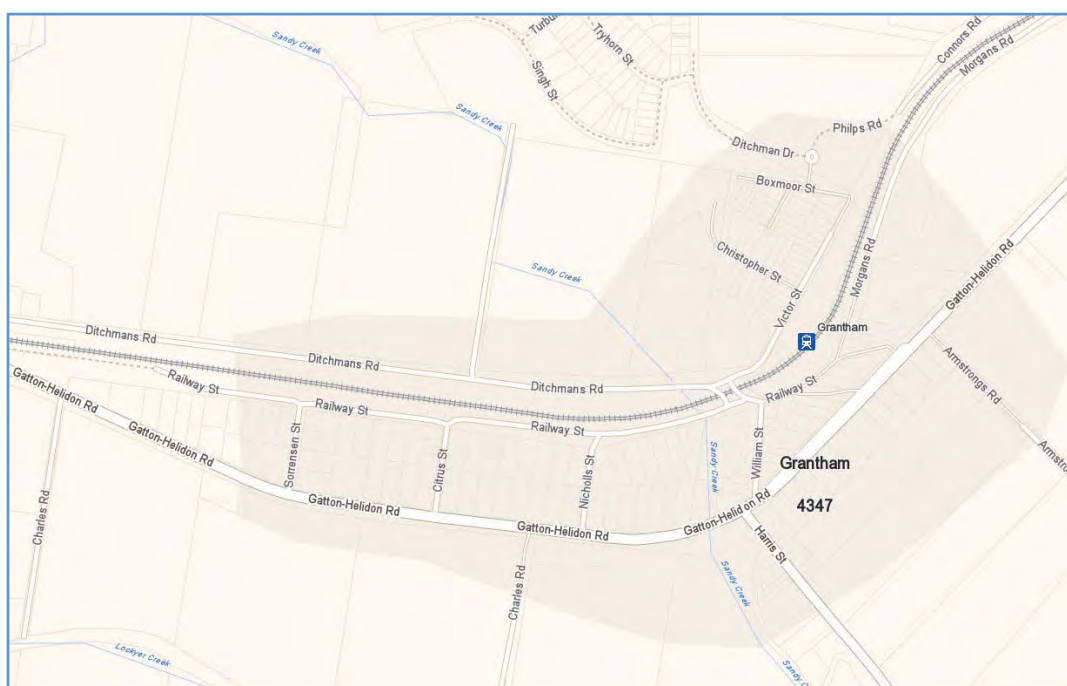

12. Periodically between 3 January and 9 January Sandy Creek broke its banks, flooded the eastern part of Grantham, and then receded. Mr McGuire and Ms Clarke-Jibson responded accordingly.
13. On the morning of 9 January Mr McGuire's supervisor informed him that the Rural Fire Brigade Control Centre, which is situated in Kedron in Brisbane, had issued an order that no Rurals' vehicles were to be used in floodwaters. Mr McGuire understood that the reason for this order was that Rurals' members had not been trained in swift water rescue and so those in charge considered the use of vehicles in flood waters to be too risky. Mr McGuire did not agree with this order. He and his wife had been trained in swift water techniques in New South Wales although Mr McGuire understands that that qualification is not recognised in Queensland. In his view, the flood waters in Grantham at that time were not high enough nor moving swiftly enough to constitute any risk to Grantham 51 or to himself. Mr McGuire's judgment was that the vehicle that he used, Grantham 51, could safely travel through floodwaters up to a point and that he could judge that point before it came. It was his opinion that if it was necessary for him to use the vehicle to aid people in distress, and if he could do so safely, then he would do so whether or not he had to drive through flood waters. He was also aware that there were no State Emergency Services members in the town or nearby who could give necessary aid if he did not. For this reason, he continued to work and to use his truck to do so and, in the result, assisted a number of people over the next 24 hours.

14. On 9 January 2011, Lisa Spierling was living in Grantham with her husband Stephen and four of their five children, Hahns aged 12, Klaus aged 10, Aerna aged eight and Ilsa aged four. Their oldest daughter Niah, who was 18 years old, had moved to Gatton the week before. The Spierlings operated a cut flower business from their address in Grantham. That day they dropped their youngest child at Niah's home in Gatton and went to their farm at West Haldon, some 35 kilometres from Grantham. After spending the day there, the family returned home in the evening with their children. Ms Spierling arranged with Niah to bring Ilsa to a park between Gatton and the turnoff to Placid Hills where Ms Spierling could collect her. She was concerned that if she took the time to go to Gatton herself, she might not have been able to cross Sandy Creek Bridge again if the water in Sandy Creek continued to rise as it appeared to be doing. Ms Spierling collected Ilsa and on her return journey she observed that Sandy Creek was about to overtop the bridge. At home, Mr Spierling, assisted by his sons and wife, raised the freezers which they kept in sheds on their property onto three pavers to secure them against any flood waters. Ms Spierling saw that there was ankle deep water in her yard. This had never happened before.
15. They then decided to drive down to Sandy Creek with the children to look at conditions there. They saw a woman stopped in flood waters about 20 metres west of the Sandy Creek Bridge. The water was half way up the doors of her car. Ms Spierling looked into the car and saw that the water was over the driver's lap. They and other locals pushed the car to the side of the road.
16. Around mid-afternoon on 9 January, Mr McGuire saw a 4WD vehicle towing a Blue Care bus backwards out of floodwaters into Harris Street. Mr McGuire drove through the waters from his house to where the bus was parked in Harris Street and found that there were eight or nine elderly people on board. The bus could not be started. He towed the bus out of town east to Placid Hills and arranged for the passengers' further transport. On his way back he saw that two police vehicles were stuck in floodwaters on Gatton-Helidon Road east of Grantham. He helped the police tow their vehicles up to dry land. One of the police officers at the scene had been instructed to go into Grantham to view the situation. To ensure the officer's safety, Mr McGuire followed in his utility through Grantham to ensure that it was able to complete its trip.



17. When Mr McGuire had completed this task he received a phone call from some local residents to say that some people were stuck in their cars on Railway Street in Grantham which had flooded. Mr McGuire was working on his own. None of his fellow Rurals was prepared to defy the order from Brisbane not to use vehicles in floodwaters. Mr McGuire felt overwhelmed by the demands upon him and so he rang his group officer, Stuart Damrow, to request help.
18. Mr McGuire then assisted in recovering a Kombi van from under the railway bridge on Railway Street. This vehicle had floated with the rising floodwaters and was jammed under the railway bridge. Mr McGuire helped to shift the Kombi van to dry ground. He then received a phone call from Mr Damrow who asked him to come to Gatton to

collect him and a senior officer from Bundaberg and to bring them to Grantham to inspect the situation. He did this. As they drove through Grantham, Mr McGuire observed that the water was still rising. For this reason, after returning Mr Damrow and the other officer to Gatton, he decided to return to his house by means of the Warrego Highway on the Gatton Bypass. He finally got home on the evening of 9 January, but later that night he was asked by the Rurals to attend to a medical emergency at Roberts Street, Grantham. To do this he had to travel back using the Gatton Bypass again. He reached the address and in Grantham 51 he carried two people in need of medical assistance through flooded waters to Withcott, a town at the foot of the escarpment below Toowoomba, where he gave them into the care of the Queensland Ambulance Service. Once again, he travelled back home along Gatton-Helidon Road. At Dinner Corner, on the western side of Grantham, he saw that the road had about two feet of water over it.

19. In the meantime, Ms Clarke-Jibson had also been working, assisting a stranded motorist who had attempted to cross flooded waters at Sandy Creek. This was probably the same woman whom Ms Spierling had seen trapped in a car with flood water up to her waist.
20. Things became busier. Members of the Helidon Auxiliary Fire Brigade arrived at the McGuire house to tell Mr McGuire two swift water rescuers had been summoned from the Gold Coast to assist but would be unable to arrive for another two hours.
21. As I have said, Mr McGuire had not previously experienced any flooding in Grantham. For him, all of this was a new experience. Long-time residents took these events as a matter of course. Perhaps because of this difference in experience, Mr McGuire became concerned about all of Grantham becoming flooded and about the possibility that many more people were going to require help and that he and his wife, as just two members of the Rurals, might not be able to cope if things got worse.
22. He took a drive around the town to check on water levels. It was close to midnight on 9 January and he saw that the water coming down Sandy Creek was flowing fast and that it was higher than it had been since Christmas Day. In Railway Street the water had actually risen to a height that reached two or three inches above the floor of the cab of Grantham 51.
23. Mr McGuire called Mr Damrow and told him that he thought the Rurals should evacuate the low lying areas of Grantham while it was still possible. He understood that Mr Damrow contacted his own superiors about this but was informed that it was not possible to force any evacuations. Of course that was true but, as I understood Mr McGuire, he was thinking about the Rurals advising residents to evacuate rather than forcing them to do so. Mr McGuire was instructed to stand down and return home and he did that. Members of the Auxiliary Fire Brigade were still there when he arrived, still waiting for the arrival of the swift water rescue team and he stayed awake into the night waiting with them. By now it was about two in the morning.
24. Things stayed busy even at this hour. A resident of Harris Street arrived and said that he wanted to drive through the floodwaters to his home where his young son was alone. Mr McGuire persuaded him not to do this. In the meantime, a radio message came to inform him that Grantham 52, occupied by two other Rurals, had been washed off the southern side of the Gatton-Helidon Road near the Grantham Hotel. The swift water rescue team then arrived with a boat and evacuated the crew of Grantham 52 and delivered the father of the boy to his residence in Harris Street.
25. The swift water rescue crew and the Auxiliaries then left. But Mr McGuire received a phone call from police who asked him if he was willing to continue to man the road-block outside his house to ensure that traffic from the west did not enter floodwaters. Mr McGuire parked Grantham 51 across the road and sent his wife to bed, while he sat in the cab of Grantham 51.

26. On the morning of 10 January the water was still as high as it had been the night before. Mr McGuire reported in to his superior and informed him that he was “Code 5” which meant that he had come off duty but was contactable by phone or radio. Nevertheless, he stayed and dozed in the seat of his truck parked across Gatton-Helidon Road.
27. That morning Ms Spierling drove to Gatton to buy groceries and to attend to some work. Knowing that the road through Grantham itself was impassable, she travelled by way of the Gatton by-pass. She then returned home the same way and spent the day baking.
28. At 10.30 am Mr McGuire, asleep in Grantham 51 parked across Gatton-Helidon Road, was woken by a Helidon police officer who had just arrived. He informed Mr McGuire that the water had gone down sufficiently to remove the “Road Closed” signs. Mr McGuire did this and moved his truck onto his property and went to bed. He was awoken shortly afterwards by two other Rurals who asked for his help to recover Grantham 52 from where it had been stranded the day before. Together they drove down in Grantham 51 and recovered the other vehicle. Mr McGuire towed it to his own property and informed the Rurals that he had done so. He had been working for many, many hours without sleep until this time. Again, he went to bed.
29. Martin Warburton had been living in the Grantham area for 25 years. He was the owner of Marnell Village Petroleum at 28 Anzac Avenue, Grantham. He had been running this business since 1993. It was a small convenience store and fuel depot. He was familiar with the pattern of flooding in Grantham. In December, when he realised that there would be a flood, he had parked his car on high ground at the railway line. He observed the flooding between Christmas and 10 January. He also kept an eye on the Bureau of Meteorology website. This confirmed his own opinion that there would be more flooding to come. On 9 January, calculating that the waters would overtop Sandy Creek, he drove from his residence to his business at 28 Anzac Avenue to prepare it in his usual way by placing items that might be damaged by water at higher levels. As he had expected, by 5 pm on 9 January the water had flooded through his shop. He sat on a chair at the front of his premises and watched the flood. He observed the swift water rescue team that Mr McGuire had been awaiting arrive from the direction of Placid Hills in the east in a canoe and a tinny. He gave them advice about how to enter the town. By then, the water in his shop was knee-deep and he saw that if he walked further out onto Anzac Avenue the flow was so severe that it would have dragged him away. Mr Warburton stayed at his petrol station all night. At about 8 pm the water rose again. He observed that it overtopped the flooding of 1996 by a couple of inches.
30. By daylight on 10 January Mr Warburton saw that the water was receding and, by 9 am, there was no water in his shop and it had stopped flowing down Anzac Avenue. There was no rain and he began to clean his shop. Then it began to rain again.
31. Late on the morning of the 10th, Mr Warburton went for a walk around the town to see what damage the flood had done and to have a look at the water level in the creek. He saw that the water was lapping the top of the culvert on the bridge over Sandy Creek on Gatton-Helidon Road. At about midday he went to the Grantham pub on Anzac Avenue to have lunch. He and some other local residents helped Lance Richardson, who ran the pub, to unload his stock. Mr Richardson had bought stock for his hotel as usual in Toowoomba and needed to put it away. It began to rain heavily.
32. Mr Warburton walked back over to the bridge again. He saw debris backing up against the culverts. He walked up to the railway line from where he could see that the water was too deep across the access road for a car to get from the western side of Railway Street across Sandy Creek to the eastern side, but it was still possible to get underneath the Railway Bridge to go up to Victor Street up past the school. He saw water flowing backwards up Sandy Creek from Lockyer Creek; that is to say, the flow in Lockyer Creek was so furious that the waters in Sandy Creek could not penetrate them and were backing up. Mr Warburton put rocks down on the roadway of Railway Street as indicators to see how fast the water was rising and saw that it was rising quickly.

33. Henry Stephenson, known as Bob, has also been a long-time resident of the area. On 10 January at mid-morning he had received a call from his brother-in-law who lived near the creek at Helidon. His brother-in-law told Mr Stephenson that an enormous amount of water was flowing down the creek and that the people in Grantham would be in trouble. Mr Stephenson who had long experience of flooding in Grantham, none of which had been dangerous, had difficulty accepting what his brother-in-law had told him.
34. Mr Warburton also received a similar piece of information. Early in the afternoon he received a call from his friend, Tim Pickering, who told him that he had seen the water lapping the bridge at the park on the Warrego Highway near Helidon. The height of the bridge over the creek at this point is in the order of twenty metres, as I have myself observed. Mr Warburton found it difficult to believe that water in Lockyer Creek could reach that height. Mr Pickering told him to get out of Grantham because there was a big wall of water coming and that Grantham was going to go under.
35. Then Mr Warburton's wife, Janelle, rang him from home to say that Ma Ma Creek, which lay on the western side of Grantham, was banking up, as was Flagstone Creek. She told him that Lockyer Creek was about to break its banks.
36. Wayne Lack was another long-time resident of Grantham. In January 2011 he lived with his wife, Christine, on Anzac Avenue. He had experienced the 1996 floods in Grantham as well as the floods between Christmas 2010 and 9 January 2011. He knew how the creeks normally behaved. On 9 January the water had risen to about three inches beneath his house, which is a two-storey dwelling and open underneath.
37. There is a general store on Anzac Avenue. It opened at about 2 pm on 10 January. The joint owner of the store, Sandy Halliday, was there as well as Mr Lack and his wife. Mr Lack was helping Ms Halliday place her fridge and other items up as high as possible to avoid damage from the floodwaters. While they were doing this a woman came in and said that the water was over the Helidon Bridge. Someone else then arrived and repeated this information. This was, of course, the same information which Mr Warburton had received. Mr Lack was also incredulous; water rising in Lockyer Creek to a level of twenty metres under that bridge was unimaginable. It was beyond all local experience.
38. Another long-time resident of the area was Steven Whitehouse. At about 1:30 pm on 10 January he was driving to Gatton from his residence at Carpendale, which is on the western side of Grantham, to return some videos. He knew that the road into Grantham was flooded so he drove from his house in Gormans Road, Carpendale, towards Flagstone Creek Road. As he went over Mahons Bridge on Carpendale Road he saw that Flagstone Creek was swollen. It was running backwards to the south from Lockyer Creek. The water was lapping the bridge. He decided to return home because he was concerned that he might not be able to get back if the water rose further. By the time he turned around and had crossed the bridge to return home, the water was already over the bridge itself. It had risen more quickly than he had ever seen. Normally the water flows from Flagstone Creek into Lockyer Creek in a northerly direction but now it was flowing backwards blocked by the force and speed of water in Lockyer Creek. Within five minutes he saw that the farm at the intersection of Flagstone Creek Road and Carpendale Road, which was bordered by Lockyer and Flagstone Creeks, was flooded.
39. Jonathan Sippel was living on Gatton-Helidon Road with his wife Annaka and their two sons. In January 2011, the two boys were two and a half years old and nine months old respectively. Mr Sippel had grown up in the area. The Sippels' property is adjacent to Lockyer Creek on the northern side of a horseshoe bend which the creek forms at that point. Within the horseshoe bend is the Grantham quarry about which I will say more later.
40. Mr Sippel had seen Lockyer Creek running heavily between Christmas and 10 January. He and his family went to Toowoomba on the morning of 10 January to buy gumboots. Afterwards they went to Mr Sippel's parents' house in Tenthill, on the western side of Grantham, for lunch. Although the former owners of his property had told Mr Sippel that the property had never flooded in the 30 years that they had owned it, Mr Sippel was still concerned by

the heavy rainfall. In particular, he was aware of the existence of a tall embankment on the western side of the quarry pit abutting the creek. He was worried that that embankment might divert water along the creek onto his property.

41. The Sippels returned home from Mr Sippel's parents' house along Mt Sylvia Road, onto Gatton-Clifton Road and then down Grantham-Winwill Road across the Thistlethwaite Bridge into Harris Street and finally along Gatton-Helidon Road to their home. The roads were passable. They put their children to sleep and prepared to spend a relaxing afternoon.
42. The intensity of the rainfall on 9 and 10 January 2011 caused dangerous flash flooding to occur in Toowoomba. On 10 January the situation became serious. Torrents of water through the centre of the city cut it in half. It was difficult for traffic to move and impossible in some areas. Early in the afternoon the New England Highway to the north of Toowoomba was cut at Mount Kynock by a landslide. Then the Warrego Highway to the east was cut by flooding preventing police accessing the Lockyer Valley from Toowoomba. Because of the fog and rain, for a period helicopters could not fly into Toowoomba or over the Murphys Creek and Postmans Ridge area. The flooding in Toowoomba immediately resulted in calls being made upon police for assistance.
43. The Lockyer Valley area falls within the Toowoomba Police District. Gatton and Helidon are two of the divisions within that district, both overlapping Grantham. Brett Schafferius was a Detective Inspector attached to the Toowoomba Police District in January 2011. In that month he was Acting Superintendent of the district. In that position he was also the District Disaster Coordinator for the relevant area under the *Disaster Management Act 2003*.
44. An indication of overwhelming strain upon police resources caused by the floods in Toowoomba can be inferred from the fact that whereas, on a typical Monday the 000 line at Toowoomba receives about 60 calls, on this day 883 such calls were received.
45. Using his available resources, Acting Superintendent Schafferius appointed senior officers within the district to perform particular roles.
46. As to the situation in Grantham, at 8 am on 10 January Senior Sergeant Jamie Deacon, who was the Executive Officer of the Toowoomba District Disaster Management Group, had spoken with the Lockyer Valley Regional Council Mayor, Steve Jones. Mr Jones told Senior Sergeant Deacon that, although floodwaters were still flowing, they were now receding. It was not raining and if there was no further rainfall then no further issues were to be expected. Senior Sergeant Deacon received similar information from Gatton just before 10 am. He was told that the only issue was Sandy Creek at Forest Hill which was rising.
47. In Toowoomba there was a meeting of the Toowoomba Disaster Management Group at 1 pm. During the course of the meeting its members were informed about the landslide at Mount Kynock and also one on the Toowoomba Range. The District Disaster Centre was then activated. The running sheet for the District Disaster Centre started to record an almost minute by minute series of emergencies arising, including children being washed away, cars being washed away in the Toowoomba CBD area containing unknown numbers of occupants and a house being swept away at Murphys Creek.
48. In these circumstances it is understandable that Grantham was not yet at the forefront of anybody's attention on the morning of 10 January 2011.



49. Mr Sippel's sister, Amy, rang from Toowoomba to tell him that she needed help because her house was being flooded. He said that if they had had so much rain up there it would not be possible for him to get up the Range or to return.
50. He realised that the water referred to by his sister was going to come down the escarpment towards Grantham. Phone records show that this conversation took place at 2:20 pm.
51. Mr Sippel went outside and looked at the creek. It was flowing normally.
52. Harry Castle is in his 80s and has lived on Gatton-Helidon Road for many years. He raises cattle and conducts a farming business on a property which borders Lockyer Creek. At about 2 pm on 10 January he saw that there was a considerable amount of debris starting to flow down the creek. He immediately rang 000 and advised the operator that he thought there was going to be a major flood. He thought the high voltage power lines would go under water.
53. Another long-term resident of the area was Gavin Zischke. For 17 years he has lived on Lockyer Creek Road, Helidon. That location is about five kilometres west of the quarry and above Flagstone Creek Road near Kapernick's Bridge. Lockyer Creek runs past his property. Mr Zischke's wife, Kelly, returned home from Toowoomba at about 2:30 pm. At that time the creek had not yet broken its banks. Very shortly afterwards it did so. Mr Zischke saw that the creek was muddy and full of debris. It rose swiftly and by 3 pm it had broken its banks so that the water had gone past his shed. Within 12 minutes it had risen further and flooded his dog kennels. His dogs were treading water. At the shed the water was waist high and Mr Zischke had to lean against the flow to prevent being swept away. He saw waves coming down the creek, each a few minutes apart from the earlier one. With each wave the water level became higher and higher and spread further onto his property. By 3:17 pm he could see the creek carrying away boats and massive trees. By 3:24 pm his shed was completely under water. Two tanks full of rainwater were sucked out of the ground by the force of the flowing floodwater. His tractor was swept aside and his shed was ripped out of the ground.
54. Anthony McIntosh lived on Klucks Road, Carpendale. This is situated to the west of Grantham and to the west of the quarry. On 10 January he was at home with his daughter, Hope, and her boyfriend. They had left home at mid-morning to keep a dentist's appointment in Toowoomba. Before they reached their destination, Mr McIntosh received a phone call. His friend, Peter Campbell, in Toowoomba told him that there had been 200 millimetres of rain in Toowoomba and the creek was flooding. He decided to head home and turned around at the Postmans

Ridge turnoff about two kilometres east of Withcott. By then traffic had backed up for about one kilometre. About half a kilometre before Helidon Spa he could see that the creek had risen two to three metres in the 10 or 12 minutes that had elapsed since he had driven past it earlier.



55. Lockyer Creek runs past Mr McIntosh's house. When he arrived home and saw the level of water in the creek he formed the view that Grantham would be in trouble. At 3:09 pm he began to make a series of phone calls to warn people. At 3:22 pm he spoke to a police officer. He informed him that floodwater was going to hit Grantham in a very short time. He said that the water had come down faster than he had ever seen it before and people should be warned. While he was making these calls he saw Lockyer Creek break its banks and flood the area of land between his house and the creek. Phone records show that this happened at about 3.18 pm. Within five to 10 minutes the water had reached the level of the windows of his house. In his judgment the water rose about a metre every few minutes. Looking west he could see that water was pouring over Kapernick's Bridge.
56. The warnings that had been given were all true and the water in Lockyer Creek continued to move towards Grantham.
57. Kathleen Mahon has lived in Grantham all her life. She was familiar with the patterns of flooding and knew that there would always be time to prepare. On 10 January her daughters, Jessica and Andrea, together with Andrea's two sons, Liam and Lachlan, had come to her home for lunch. It was not raining. Andrea's partner was in Toowoomba. He rang her to say that his workplace in Toowoomba was flooding and that she might have trouble getting home. They all went down to have a look at Sandy Creek at the railway bridge. The water by that stage had risen considerably from the levels at lunchtime. Andrea and Jessica decided to drive back to Toowoomba and Ms Mahon and her husband returned home, but upon arriving at home, Andrea reached them on their car's two-way radio and asked her parents to join her. She was concerned about the level of water. Ms Mahon and her husband drove up to the corner of Flagstone Creek and Gatton-Helidon Road. There was water over the right hand side of the road. Some people who had just driven down from Toowoomba said that Withcott was flooding and nobody should drive in that direction. Together they drove back down Gatton-Helidon Road. At Dinner Corner Mr Mahon said "Look at the creek, I can see the creek". This was remarkable because the creek was normally not visible from Dinner Corner.
58. Somebody reported over the car's two-way radio that the water was over the bridge at Helidon. Mr Mahon's reaction was "Bullshit, it never goes over that bridge".

59. Closer to Grantham, Jonathan Sippel was still watching the creek. Mr Sippel's neighbour is Neville Mallon. They were calling each other repeatedly that afternoon after 3:00 pm to discuss the situation and to consider the significance of the embankment at the quarry. Mr Sippel asked Neville Mallon what he could see the creek doing around the back of the quarry. Mr Mallon said the water was rising. A great amount of debris was coming down the creek and the roar of the water was astonishing. Mr Mallon said that he had been watching the water and had observed that it was backing up near the embankment and was starting to spill over into the quarry.
60. Mr Sippel called his neighbour, Tom Friend. Mr Friend was very familiar with the area. He had lived at Quarry Access Road for 11 years. He had seen the area around Quarry Access Road change from a flat paddock to the quarry that it ultimately became. He had experienced the 1974 flood when the quarry had not yet been developed. When Mr Sippel rang him, Mr Friend was on holidays at Hervey Bay. He advised Mr Sippel that there was nothing to worry about because even in the 1974 floods the water had never reached the Sippels' property.
61. Mr Sippel received a phone call from Steven Kluck who asked him what was happening in the creek. Mr Sippel said that it was rising. Mr Kluck told him to leave immediately. Mr Kluck said that he had seen a power line washed into the creek and he was beginning to worry. Mr Kluck told him that at Kapernick's Bridge, west of Grantham, the water had reached a level about a foot under the bridge. Mr Sippel knew that that meant that the water was about three metres higher than he had seen it on Boxing Day 2010. He knew then that the creek would break its banks. Kapernick's Bridge was only two kilometres away and he saw that he would not have much time to evacuate his family. Mrs Sippel was astonished and shocked at the news. In her experience the water had never had come even to a half way point between the base of the creek and Kapernick's Bridge.
62. Mr Sippel continued to communicate with Neville Mallon while considering what to do. At 3:39 pm he again rang Mr Friend. By then the creek had broken its banks. Mr Friend's cows were agisted in Mr Sippel's property and Mr Sippel asked what he wanted done with them. Mr Sippel let Mr Friend's cows out and rang his parents at 3:42 pm and it was they who advised him to leave immediately.
63. Mr Sippel recalls telling his wife to collect whatever was necessary in case they had to evacuate the property. They looked towards the creek and saw that the water had started moving towards the back of their house.
64. Ms Mahon had been receiving further warnings. Her other daughter, Rachele, phoned her to say that she had seen a warning on television about a "wall of water in Toowoomba". Rachele told her mother to get home and get as high as she could. Ms Mahon remembers that she wasn't really paying attention and so her daughter was shouting at her "Mum, can you please listen to me, get as high as you can". It seemed to her that her daughter was beginning to panic. Then Ms Mahon's nephew, Michael, rang to say that he was at the bridge at Helidon. He said the water was going over the bridge and everyone had been saying that there's going to be a "wall of water"; he urged Ms Mahon to get to higher ground. Ms Mahon was at her own mother's house at Grantham at that point. She was trying to persuade her mother to come with them but her mother refused. The Mahons, their daughters and two grandsons then went home. The phone rang as Ms Mahon arrived home. It was her neighbour, David James. She told him about the information concerning the wall of water coming to Grantham. He was disbelieving and commented that she sounded as though she was panicking.
65. Mr Warburton walked down William Street and Anzac Avenue. There was no water over the road. He stopped at the general store and spoke to Sandy Halliday. She too was concerned about the water height in Helidon. Mr Warburton said that in his opinion they should evacuate. In his view it was likely that the water would be chest deep through town. Ms Halliday closed her shop. Mr Warburton returned to his petrol station.
66. At about this time Michael Darlington had received a phone call from his son who had been unable to cross Kapernick's Bridge because of water over it. Mr Darlington went for a drive in his truck along Railway Street and turned left into William Street. When he began his trip the water level appeared to resemble the normal flood

pattern in Grantham. But when he reached Gatton-Helidon Road he saw that the water was rising fast. He panicked and turned around and drove his truck to high ground near the railway station. He heard a call over his two-way radio from someone who said that it looked like a dam wall had burst. He walked back to his house. When he arrived at his home on Anzac Avenue the water was three feet deep in his yard. In the time it took to walk the length of a Pantehnicon trailer parked in his yard, which was 45 feet long, the water rose a foot. He worked to lift his possessions to higher ground. His wife tied his two boats to secure them.



67. Conditions deteriorated rapidly from this point.
68. Ms Spierling did not have any of this information. She had not yet received any warnings from anybody. In the early afternoon, at about 2:30 pm, she and her children had driven to Gatton to attend to some banking. Mr Spierling had gone back to the farm. Ms Spierling rang the general store to find out if the road through Grantham was open. It was clear and so they travelled on it, passing Sandy Creek Bridge where she saw that the water level had reached just under the bridge itself. They returned home just after 3 pm. Ms Spierling drove down Citrus Street past her home to examine conditions on Railway Street. There was water at the bottom of Railway Street, near the creek, but this was completely normal. She took her children home and continued baking. Her husband phoned at about 3:10 pm to say that he was coming home because there was too much rain at the farm.
69. On his way home Mr Spierling phoned home again twice. His final call was at 3:39 pm. He said that he was on the Toowoomba Range and the road was closed. At about the same time, Neil Robertson was at Withcott. He saw that traffic was stalled. Facing west he could see water coming through Withcott at a height of five to six feet.
70. Frances Arndt and her husband, Kenley, were at home on Gatton-Helidon Road. They had lived in Grantham for almost 20 years. Between 3 pm and 3:30 pm Mr Arndt's daughter, Kym Evans, rang to warn them that they had to get out quickly. Kym was standing on high ground on Carpendale Road. She could see that the Lockyer Creek had broken its banks and water was spreading out across farmland, heading for Grantham.

71. Janet Crust and her partner, Ian Pinkerton, lived across the street from the Arndts. Ms Crust, phoned Ms Arndt to get Mr McGuire's number. Ms Arndt gave her the number. Ms Crust was speaking from her back deck and could see to the south. She saw that Lockyer Creek had broken its banks. A foot of water was crossing the flat land from the creek towards her, from south-west to the north-east. As she watched, the level of the water grew higher. Ms Arndt heard her say "Oh, my God! The Lockyer Creek has broke its bank".
72. Nearby at Quarry Access Road, Graham and Helen Besley had been watching the nearby Lockyer Creek rising and were growing more and more concerned. At 3 pm the power had gone off. At about 3:30 pm they had walked over to the edge of their property to look at what they thought was the Lockyer Creek but in fact was the gravel roadway running down to the plant area of the Grantham sand plant. The creek had already broken its banks and water was running down the roadway. The water had risen to the base of a fence which was level with Quarry Access Road. As they watched, in the space of three or four minutes the water had risen to the top of the fence, a height of just over a metre. The water had another metre and a half to rise before it would be running onto their property. They decided to leave. Ms Besley gathered some important valuables and went to meet Mr Besley who had gone to get the car. Within minutes, the water was up to her ankles.
73. Zelda Jamieson also lives on Gatton-Helidon Road, about two kilometres north-east of the township itself. From her property she has a good and uninterrupted view to the south-west across flat country towards Grantham. Lockyer Creek runs west to east across the rear of her property. At about 3:30 pm her husband had received a phone call from a friend living on a property on Flagstone Creek. He said that a big wall of water was coming down from Toowoomba which was likely to affect Grantham. Ms Jamieson and her husband went outside to look. The Lockyer Creek near their property was high but had not yet broken its banks. Towards Grantham, however, she could see what looked like a white strip of water travelling in her direction. In 46 years she had never seen anything like this. She could see that this wave of water was flowing very strongly and was full of debris.
74. At the same time Mr McIntosh was still at his property watching the water flow from west to east. He estimated that it was rising by a metre every few minutes. He could see well established trees snapping under the force of the water.



75. Very shortly after Ms Spierling had spoken to her husband at 3:39 pm, her son Klaus informed her that a neighbour, Robert Wilkin, wanted to speak to her. Mr Wilkin told her that he had heard that the water was rising and suggested that she might want to move her car to higher ground. Ms Spierling decided to do that. There was no sense of danger. However that changed almost immediately. Mr Wilkin returned and said "Get the fuck out!" He

picked up the youngest child, four year old Ilsa, and Ms Spierling and her two sons and other daughter followed him out of the house to his ute outside. Ms Wilkin and her three girls, one of them just a baby, were already in the front seat. Mr Wilkin's house was on the corner of Citrus and Railway Streets. He had come back towards the floodwaters to collect Ms Spierling and her children. Mr Wilkin put Ilsa in the cab of the ute. Ms Spierling and her sons jumped into the ute's tray and Mr Wilkin backed quickly out of the driveway. Ms Spierling could see water rolling across the landscape towards them from the direction of Lockyer Creek in the south; it was like a wave rolling in at the beach. At that moment, she could still see land clear of flood water between this wave and Citrus Street. She and her children shouted to Mr Wilkin to hurry.

76. Mr McGuire had been asleep and had been woken by his wife because Mr Arndt was asking for him. Mr McGuire went outside and met Mr Arndt who pointed towards Lockyer Creek in the south. The wave was coming.
77. Jonathan Sippel ran to his work shed, got into his ute and drove it across his block towards the front gate in an attempt to save it. The ute became bogged and he left it. He ran back to his wife and children. The water was about a half metre deep under the side steps of his wife's 4WD Challenger vehicle. He told her to wake the boys. He ran upstairs and picked up his two year old son and quickly put him in the car. He went back and collected his nine month old son and also put him in the car and drove out of the driveway whilst Ms Sippel got into their other car, a Triton. It was already surrounded by rising water. They both drove out of the roadway. Jonathan left his car and ran back to see if he could save his work ute. He could hear his dog yelping from his pen. He rescued the dog and brought him back to the car before trying again to save his ute. It wouldn't budge. When he got back to the roadway he found that his wife had already moved both cars to a higher point. They then drove to Dinner Corner, a relatively high part of Gatton-Helidon Road.
78. The Besleys had managed to get into their car. Mr Besley reversed it into his driveway with the rear of his car facing west. He then drove east and then north following his driveway around the house. Ms Besley rang 000 and was connected. Records show that this happened at 3:47 pm. As they came around the front of the dwelling a massive wave of water engulfed the car. It picked up the vehicle and pushed it across the property and over a wire fence. The car began to fill with water. Neither of them could now open the doors against the pressure of the water outside. Miraculously, the electric window switches still worked and they were able to bring the windows down. They each climbed out and stood on the window sills holding onto each other over the top of the car, anchoring each other in place. Wave after wave broke over their heads straining them. They saw the sheds on their property collapse like a pack of cards. They grew exhausted and a wave at last washed them off the roof of their car. Ms Besley managed to dog paddle to the wreckage of the sheds. Mr Besley was carried away. Ms Besley saw him go as she held on for her life.





79. Ms Besley didn't know whether her husband was alive or dead or where he was. But by some inexplicable and miraculous train of events the water which had been flowing eastwards looped back and brought him close to where she was clinging to the wreckage of their sheds. She scrambled towards him. As she explained it, she bullied at him, yelled at him and screamed at him to climb higher. He was exhausted and struggling. The force of the water had stripped his clothes off. Nevertheless, he managed to climb a little higher and to survive.
80. Ms Arndt did not panic. She collected her mobile phone and that of her husband. She took the time to make an entry on her Facebook page to advise her family that they might have to be evacuated. She walked out to where her husband was standing on the street in front of their house. He was talking to Mr McGuire. She said, "Let's get out of here. Kym's been on the phone yelling for us to get out of here". By this time she too could see across the paddock south towards Lockyer Creek that a large sheet of water was heading towards them. This is consistent with the view that Ms Jamieson had from her property to the east of Grantham and also with what Ms Crust had seen. Ms Arndt described it as being like a wave at the beach as it comes up the sand.
81. Mr McGuire saw a wave about one metre high coming over the paddock filled with debris. The water was coming fast and he remembers seeing a house being pushed by the floodwaters in a north-easterly direction. He called out to his wife and children to "Get in the bloody truck, hurry up".





82. Ms Arndt and her husband got into their ute. As they were about to drive off, Ms Arndt can remember looking over to Ms Crust's house and seeing her running from her front yard into her own house. She could see that the water was by then already covering the tyres of the vehicles at Ms Crust's house. Mr Arndt drove off along Gatton-Helidon Road towards the west. He knew, of course, that the road was flooded by Sandy Creek in the east and so did not consider driving that way.
83. Mr McGuire's fire truck, Grantham 51, was parked in his driveway facing Railway Street. It was still attached to Grantham 52 which Mr McGuire had towed to his house. He cut the snatch strap connecting the two vehicles and turned Grantham 51 around in his yard to face the Gatton-Helidon Road. He saw that Mr and Ms Arndt were driving out of their property and starting to head west on Gatton-Helidon Road.
84. The wave from Lockyer Creek had now reached Ms Crust's home. Her sister and brother-in-law, Mandy and James Shannon-Cooper and their two children, Katieann, aged 19 and Maddison, aged 14, were staying with them. Ms Crust recalls that she was telling them that it was normal for it to flood in Grantham and that the water would not affect them in the house. As a matter of prudence, they moved furniture and other articles to higher position although nobody expected that conditions would worsen. They were taking the time to video the rising waters.
85. But the water was still rising and as it rose its force was so great that it smashed a panel in a glass sliding door. By then the flood around the house was over a metre high. Ms Crust, her sister and her sister's two children were now sheltering upstairs. Mr Pinkerton and Mr Shannon-Cooper were still downstairs and the water was now up to their chests. They too went up to the first floor, but soon the water had reached even the veranda. Mr Shannon-Cooper climbed up onto the roof. Mr Pinkerton arranged the outdoor furniture so that they could all clamber onto the roof.



86. Mr Wilkin, with Ms Spierling and her children in the ute, drove up Citrus Street away from the water and stopped the car outside his house. Ms Wilkin rushed into their house to collect baby necessities and a phone. Ms Spierling picked up the Wilkins' baby and, carrying four year old Ilsa on her hip, she and the other five children ran towards the railway embankment that runs parallel with Railway Street. It was the only relatively high ground within reach. The children were screaming in fear. She could see that behind her Mr Wilkin and his brother Jim had launched Mr Wilkin's small power boat and were helping an elderly neighbour, Marcus Casalegno, into the boat. Mr Casalegno had been trying to go back down Citrus Street towards his home and towards the flood believing his wife was still in their home.
87. As Ms Spierling described it in oral evidence, her two sons reached the top of the embankment first and she "threw the children at them onto the railway line" to safety. She then climbed up herself.
88. The water was coming still swiftly across the paddocks from the south-west. As it hit the table drain at the edge of the road it burst into an even higher wave as it came towards Mr McGuire. He thought that Mr and Ms Arndt would be in serious trouble. He immediately called the Rural Fire Brigade on his radio asking for urgent assistance. This call is recorded as having been made at 4:01 pm. He said that Grantham west bound had been inundated and that the Lockyer Creek had burst its banks. He said 35 to 40 people would need evacuation. A few minutes later, at 4:05 pm he reported that his neighbours, the Arndts, would need assistance. He used the mobile phones, his own and his wife's, to ring 000 with a warning. As he was doing this his wife and his children got into the truck. The water was in his front yard running fast. Llync told him that a 44 gallon drum had wedged itself under the bullbar in the front of the truck. He moved off. The truck dipped into the table drain and was below the level of the roadway. At the same time, the water coming from the south hit the lip of the road again and that lifted it up over the truck, like a big wave. It went over the top of Grantham 51. He called on the radio for help.
89. Andrea Foyle was at her parents' house on Gatton-Helidon Road. She was there with her children, her sister and her mother. The water had trapped them in the house. As the waters rose she called her husband, Matthew, to say goodbye. She thought that they would all die. Her small sons were standing on the breakfast bar. The water was gushing in through the front bay windows of the house facing the road. The force was so great that the water pushed the refrigerator over. She and her sister decided to get on the roof. Her sister climbed up first and Andrea passed her sons up. Then she clambered up herself.



90. Allan Marshall lived at Harris Street. His neighbour, George McEwan, who lived across the street, had received a call after 3 pm in which he had been told that the water in Lockyer Creek had risen over the guard rail of the Helidon Bridge. He told Mr Marshall about this. At the time Harris Street was dry and it had not been raining. He and Mr McEwan dismissed the information. However, they had moved their vehicles to the high ground at the railway yard. By the time they returned to Harris Street there was a foot of water on the road. Within a few minutes it had risen to over a metre. Water was now going through Mr Marshall's house. He joined Mr McEwan and his wife at their house and they watched the water rising. He saw his own house lifted off its stumps, tilted around as the water rose to the level of the gutters. They crawled into the roof cavity of Mr McEwan's house and smashed a hole through the roof sheeting. They looked through the opening towards the west. As far as they could see the country was flooded. The water flowed carrying cars and other heavy objects.
91. Allan Marshall's father, Bruce, was 66 years old. In January 2011 he too lived on Gatton-Helidon Road with his wife, Shirley, and his other son, Aaron. Mr Marshall had a number of health problems and was not able to walk without assistance. At about lunch time Ms Marshall and Aaron had gone to Toowoomba leaving him home alone. Their daughter, Fiona Latz, lived in Oakey. She rang her father and asked him whether he was watching the creek. He said, "Don't bloody worry about it. It doesn't come up that high". They spoke for a while longer. Her father said, "The power's gone out". Ms Latz asked him whether he had paid the electricity bill and he said he had. Mr Marshall said, "The water is up to the top step of the house. Now it's coming through the bloody floorboards. I'm looking out the front and all I can see is a bloody lake of water across to the meatworks. I've got to go and ring SES".

92. Ms Latz then rang her brother, Allan Marshall. She asked him to go and help their father. Allan could not possibly do so. At that very moment he was desperately trying to break into the ceiling of Mr McEwan's house to get his wife and children to safety.
93. Bruce Marshall used his mobile phone to ring 000. He told the operator that the water was up to his waist and that he needed help or he would drown. The operator attempted to transfer his call to police communications but the call dropped out. This call was made at 4:11 pm. A minute later Mr Marshall again rang 000. He was transferred to Ipswich Police. Again he said the water was up to his waist. There was only about three feet left until it reached the ceiling. He asked for help.
94. Wendy Hodda lived on Gatton-Helidon Road in a low set brick house. On 10 January Ms Hodda's mother, Reinskje Van der Werff, was also at the house. She was 86 years old.
95. Ms Hodda's 10 year son John was also there. That morning Ms Hodda's daughter had dropped off her own three children and had gone to work. These were Elisha aged seven, Corban aged five, and Mercedes aged two.
96. At about 3 pm Ms Hodda received a phone call from her daughter's husband, Anthony Tonner. He said that he had heard that there was a torrent of water at Withcott. He called again about 20 minutes later and said, "Wendy, I want you to get the kids on the roof!"
97. He told her to get a ladder and get everyone up. Ms Hodda said, "What about Oma?" This was a reference to her mother. Ms Van der Werff's medical condition was poor and she lacked mobility. It was not possible to bring her onto the roof.
98. Mr Tonner said, "Put her up as high as you can, there's a lot of water coming".
99. Ms Hodda ran to the shed and brought a ladder back to the house. She leaned the ladder up against lattice work and secured it. She went back into the house. Her mother was sitting in her room. She spoke to her son, at ten years the eldest, and said, "John, I need your help, I need to get the children on the roof, I need you to help me".
100. She told the children they had to get on the roof. She asked John to climb up the ladder onto the roof and to help her with the other children. Ms Hodda went inside and picked Elisha off the table where she had placed her and put her on the roof. John climbed onto the roof and helped Elisha over the top. Ms Hodda went back and got Corban and put him on the ladder. The ladder was too low for him to reach the roof. Ms Hodda pushed him up and John pulled him up from the roof to safety.
101. Ms Hodda went back inside. Her mother had come out of her room with her walking aid and asked what was happening. Ms Hodda said she needed to get onto the table. Ms Van der Werff tried to get up using a chair but was not able to do so. Ms Hodda obtained a stool for her to use to step onto the chair. Her mother was still unable to get fully onto the table. She used the stool and chair and was able to sit on the table.
102. Ms Van der Werff said, "This is far enough, Wendy. If it gets any deeper than this I'll swim". They both laughed.
103. The water began to come into the house. Ms Hodda said, "Oma, I have to go".
104. Ms Van der Werff said, "Where are you going?"
105. "I have to go on the roof with the children."
106. Ms Hodda picked up two year old Mercedes off the table where she had left her and ran around to the ladder. John helped her lift Mercedes onto the roof and she followed. The water rose very fast until it was about a foot below the

height of the pergola outside the house. She and the children remained on the roof. It began to get dark. She had earlier thrown up a woollen blanket and she put this over the children's back and heads to protect them against the rain and cold.

107. Ms Hodda's mother died inside the house.



108. Jean Gurr lived on Gatton-Helidon Road. She was 88 years old. She had undergone spinal surgery and had received a hip replacement. She had limited mobility. She lived alone. She was last seen at the newsagency on the morning of 9 January 2011.

109. Telephone records show that she made two telephone calls on 10 January to the home of her daughter-in-law. These were at 4:05 pm and 4:10 pm. Neither call was answered. At 4:41 pm her son, Andrew, called his mother but only heard an engaged signal.

110. Ms Gurr was later found dead inside the house. Marks on the walls of the house showed that the floodwater had reached a height of six feet.

111. In January 2011, Rodney Minns, who was a sergeant of police attached to the first year program at the Oxley Police Academy, happened to be living in Grantham with his wife and son. This was because his wife was the principal of Grantham State School. He had woken early on the morning of 10 January to find that both access points out of town had been cut by floodwaters from Sandy Creek. For that reason he did not go to work on that day.

112. At about 4:15 pm he could hear the sound of rushing water behind his house on Victor Street. He went down to the rear of his property to investigate and saw a woman running down Christopher Street towards the school, calling out words to the effect of "there are people on the roof of a car". He immediately rang 000 on his mobile phone. It was a while before he could get through. He then passed on the information he had concerning the flood and the report of the woman who had called out.

113. He told his wife to stay inside the house with their son. He then went back to the rail bridge where he saw a large volume of water crashing against the bridge and spilling over it. People nearby were in panic. Some were saving others from the water. He identified himself as a police officer and told the people around him not to risk their lives by entering the water and told them to move up to high ground to the school buildings.

114. As Marie and Peter Van Straten watched the water rise to the height of the steps of their house, the chance to leave was lost. Ms Van Straten saw their car pulled by the force of water out of the shed and against a tree. The house itself was creaking and groaning under the strain of the force of the water. The toilet and back porch were swept away. The sheds on their property collapsed and were swept away. A tree crashed into the remains of the bathroom and Ms Van Straten was pushed under water. She managed to get out and back into the dining room. The water was up to Mr Van Straten's waist and up to Ms Van Straten's neck where she was standing. The water shattered the back windows. The kitchen, the bathroom and all four bedrooms had been destroyed and swept away. The remains of the house to which Mr and Ms Van Straten still held on was swept away a distance of about 3kms to the market gardens.



115. Kenley and Frances Arndt did not get far. A wave of water hit their car head on as they attempted to go down Gatton-Helidon Road. The car began to float and shift sideways off the road towards the northern railway line. Mr Arndt was worried that the water might roll the car over. Water began to enter the car. It reached up to their necks. The car began to sink. They struggled to open the doors but could not. Mr Arndt told his wife to push the window button to open her window. He himself did so and his window went down. The window on Ms Arndt's side only went down half way and she struggled to climb out, severely bruising herself.
116. As they got out the car sank to the bottom. Mr Arndt called out to his wife to swim with the flow of the water and to try to get to the nearby trees. He feared that if they were swept past the trees they would be washed onto the railway line and killed.
117. Mr Arndt's daughter, Kym Evans, lived at Veradilla, south of Grantham on the other side of Lockyer Creek. She had been informed about the coming flood water. Together with her husband Wesley she had driven onto Carpendale Road to a point from which they could see Lockyer Creek and Gatton-Helidon Road. It was from there that she had phoned her frantic warning to Ms Arndt. Now she and Mr Evans drove over to Roses Road, near the piggery at the top of a rise, in time to see her father driving west along Gatton-Helidon Road. She rang her father's phone and spoke briefly to him before the water swamped the car. She could hear Ms Arndt shouting, "There's water coming in, there's water coming in," before the connection ended. She thought that she had seen them both die.
118. Having brought her terrified flock of children up the steep railway embankment onto the tracks, Ms Spierling was straining to keep them together and focussed on escape. She ordered them to stay in place, believing that the water

would be coming from the east, from Sandy Creek, as it normally did although never at this intensity. Standing there, she saw that the water was now a torrent below her. It had first come from the south. It hit the embankment and now turned to flow east along it.



119. In January 2011 Matthew and Stacey Keep lived on Railway Street with their three children, Madison, who was five, Jacob, who was four, and Jessica who was almost two. Ms Keep's mother, Dawn Radke, also lived there. On 10 January 2011 Mr Keep's mother, Pauline Magner, was also at the house. She lived at Harris Street adjacent to the creek and had come to her son's house believing it would be safer. Ms Keep was heavily pregnant with her fourth child.
120. That afternoon Mr Keep had taken his family down to the shop in Grantham to buy chocolate. As he drove home he could see water coming up over the paddocks from Lockyer Creek in the south. He drove down to his brother's house on Citrus Street to tell him what he had seen. By the time the Keep family returned home the water was about four inches deep around their own house. Mr Keep called the SES from his mobile phone and informed them that a wall of water was coming into his house. His mother and his wife were putting towels at the foot of the doors to try to stop the water from coming in.
121. Within two or three minutes the water was a foot and a half deep inside the house. Mr and Ms Keep put their three children onto the island bench in the kitchen. The flood was coming quickly. It burst the rear glass doors of the house. The water rushed into the kitchen and washed the children off the bench. Mr Keep was able to find Madison at the front door and flung her onto the lounge. Ms Keep found Jessica and screamed as Jacob was washed away. Mr Keep saw his son being washed through a partition in the living room. He went to search for him but could not find him. He went into the garage. Ms Magner followed him and was swept through the garage door. He was also washed out of the garage and swept away to a house on the corner of Sorrenson and Railway Streets. He held on to an air-conditioning duct.
122. Inside the house, Ms Keep got hold of Jessica and began to look for Jacob. She could not find him and thought that she had lost him. She saw Mr Keep and his mother go to the garage and washed into it and then away outside.
123. The lounge on which Madison was sitting was beginning to float away and Ms Radke was desperately trying to reach it. The water kept pouring into the house. Ms Keep fought her way through to the garage and found a big piece of plasterboard that was floating there. It was not moving and she put Jessica on top of it. She went back to help her mother with Madison but couldn't fight the force of the water. She returned and picked up Jessica. She could see that the garage door was bent. She was trying to work out a way to get herself and her daughter onto the roof away from the rising water. She placed Jessica onto the garage door and tried to heave herself up. Then the water hit her and she lost her grip. She grabbed her daughter and together they were pushed around the side of the house where Ms Keep was able to grab onto a downpipe. She clung to the pipe getting more and more tired. She looked about to see if there was a place of safety which she and her daughter could reach. She saw a house nearby. She let go hoping that the water would take her there. It was too deep to stand. Ms Keep struggled to keep herself and Jessica above the water. The water washed them up onto the railway tracks. Her legs got stuck and she and her child were pulled under. The strength of the water ripped Jessica out of her arms. Ms Keep felt herself passing out but then a current lifted her to a point where she was able to hang onto a pile of sleepers.
124. Mr Keep hung onto the air-conditioning duct of the house to which he had been swept as the water tried to pull him off. He heard screaming from inside the house and pulled his way in through a window. There he found two women and two children. He helped them onto the roof and climbed up himself.
125. Ms Spierling had watched as Brad and Natasha Long were smashed by the flood against the two metre high wire railway fence. By now, the water was flowing only about a foot below the top of the embankment.



126. At this moment, Hahns called out to his mother and pointed west. Ms Spierling looked towards the west along the railway tracks and saw that the flood waters were now coming fast from that direction and a wave was sweeping towards them over the railway line itself. She quickly ordered her group to run to the east, along the track towards the State School on high ground. Other people had now reached the embankment and were fleeing to the east. As Ms Spierling was encouraging and cajoling her group of children on their way to safety, she saw a red Commodore being swept east by the flood waters. A man was clinging to the roof. This was John King.
127. Mr Frank King lived with his wife Therese on Railway Street. He had built the house himself and, in doing so, had ensured that it would be proof against any possible flood. He had himself obtained long thick poles from the Gatton State Forest and had embedded them two metres into the ground. On this foundation he had built his house.
128. On 10 January his son John, a recent graduate of Duntroon Military College, was visiting his parents for the holidays. Mr King closely monitored the weather and the state of the surrounding waterways by referring to various websites. He had stayed up all night on 9 January because of the possibility of flood. After a short sleep on the morning of 10 January, and after lunch, he decided to walk down to Sandy Creek to observe conditions there. Mr King saw water rising fast from the direction of Sandy Creek and decided to go back home. A neighbour of his was driving his ute out of his property and shouted to Mr King whether he knew that there were 13 metres of water at Helidon. Mr King had not known that. He hurried home and told John what he had learned. Together, they

began to move articles to higher places in the home. After looking at the Bureau of Meteorology website again, he and John decided to move their cars to high ground.

129. When Mr King came out of his house he saw that the street outside was under water. The water was coming from the south. He saw his son begin to run towards his car, a red Commodore, get inside it and start the engine. John put the window down. Before he could move the car, a wave of water broke over it. He hurriedly climbed out of the window. Mr King was also hurrying through the knee deep water to the car. When he reached it, it was already floating and being pushed eastwards by the force of the water. By now, Mr King was treading water. His son's car was wet and slippery and he had trouble getting a firm grip. He clung to the car's window pillar as best he could. The car jammed against a tree where it stopped. John was lying flat on the car's roof, and grabbed onto his father's right arm. Surges of water swept over Mr King. The current brought debris with it, which hit him and, at one stage, wrapped itself around him threatening to drag him under. Mr King believed then, and believes now, that being too weak to fight the water and the flotsam hitting him, he would have drowned but for the determination and strength of his son who gripped his father and, in the end, brought him to a safe stance on the window sill.
130. The strength of the water and the weight of debris which it brought, including even heavy railway sleepers, finally broke the tree which had trapped the car and, as it was swept away, John called to his father to jump and to try to get to nearby trees. Mr King and John were sent away in different directions. Mr King managed to grab onto the trunk of a tree. The force of the current was so great that it stripped the clothes off his body. As he hung on for his life, Mr King could see people running to safety along the railway embankment. He saw Mr Wilkin and his family. He saw Ms Spierling and the children. Hanging on to his tree as the water and floating junk attacked him, he called out encouragement to them, not knowing if they heard him. There he hung on while waves broke over his head, straining him to the point of collapse, not knowing if at any moment a heavy object would strike him and kill him only having his old hat with which to protect his head. Around him he could hear the screams of other people trying to survive the rising water.



131. John also grabbed the branch of a tree but it snapped under his weight and the force of the current. He was swept down the road and tried to swim with the current. Cars were carried past him almost hitting him. Eventually he managed to swim to the front yard of his parents' house. He held onto a tree and called out to his mother and younger brother inside the house. He could not hear a reply. He managed to get to the house itself and went inside

where he found them safe. He stood on the front porch, watching people in peril unable to do anything. In this way he saw Gilbert Kilah and two young women swept past the house on the roof of a car and then into the water itself.

132. Rebecca Sparkes, on the roof of her house on Railway Street, had seen Mr King and his son on the roof of their car and now she saw him again hanging onto the tree. She called out to him that she had notified 000 about his situation and that they would come and save him. He replied, "I'm alright." He told her not to worry, that he was safe, there were others more in need of that kind of assistance.
133. Brenda Ross lived on Anzac Avenue. Her partner, Christopher Face and her sister, Elizabeth Fraser, lived there with her. Joshua Ross, Brenda's son, lived in a house behind theirs.
134. Ms Ross's health was not good. She was an insulin dependent diabetic. She was obese and had high blood pressure. Various illnesses and conditions had seen her in hospital. She needed a walking frame to move about her house and a wheelchair if she went outside.
135. The flooding between Christmas and 10 January had damaged many articles in the house and Ms Fraser and Joshua Ross were busy that afternoon putting valuable articles into high positions. Mr Face had taken his car to the railway yards and had walked back to the house.
136. Ms Ross used to drive but had recently surrendered her licence due to ill-health. In the afternoon, Mr Fraser drove Ms Ross's car up to the railway yards.
137. While she was up at the railway yards, Ms Fraser received a call from her sister. Ms Ross said the water was up to her knees. She was sitting on her bed. Joshua was with her. He spoke to his aunty. He sounded frightened. He said the lounge room was falling apart. The house was "creeping and the walls are shaking".
138. Ms Fraser knew that this meant that the height of the water above ground was over seven feet and that there was now nothing she could do. When she rang back there was no answer.
139. Lance Richardson was still at the Grantham pub next door to the Ross residence on Anzac Avenue. Mr Richardson was standing on the verandah of the hotel and heard a loud crack. He looked around and saw the Ross house collapse into the water.



140. Brenda Ross, Joshua Ross and Christopher Face were killed inside the house.

141. At 4:18 pm an operator from Toowoomba Police called Bruce Marshall on his mobile phone. Mr Marshall said that the water was now up to his shoulders. He was in the house and was unable to get out. Toowoomba Police advised him to try to get to the highest part of the house but not to go outside as the current would sweep him away. Mr Marshall said he thought he might be alright and the call ended.
142. Mr Marshall died inside the house.
143. Janet Crust and Ian Pinkerton and their family could not get away. The water had reached the second level of their house and it was still rising. She and her family could see an ocean of water outside. They could see people clinging to the roofs of their houses. They stayed on the roof of their house.



144. Raymond Van Dijk had worked late as a security guard on the previous night. He had returned home in the morning and had gone to sleep in his house on Harris Street. His daughter and her two children were also there as well as a tenant, Daniel Moore. Mr Van Dijk's daughter woke him just before 3 pm. She was concerned about the rise of water outside. The level of water at his house suggested to Mr Van Dijk that something serious was happening. Mr Moore was asleep and Mr Van Dijk woke him. They decided to move a freezer which was under the house into a higher position. By the time they had done that the water had risen to chest height on the ground floor. They went upstairs and sat on the verandah to watch the water rise. Mr Van Dijk became worried. He tore the awning off the back verandah so that it did not block a path to the roof. By stacking furniture together he made a stairway and got his daughter and his two grandchildren to the safety of the roof.



145. Having escorted his wife and children to safety at Dinners Corner, Jonathan Sippel then returned to help his neighbour, Neville Mallon. Mr Mallon and his wife, Charmaine, were loading their animals into cages onto their tractor. They had managed to park their two cars on the road. The water began to pick up speed. Mr Sippel saw his own demountable office get washed away. Mr Mallon's tractor shifted sideways with the force of the water. It was pushed into a tree. The water that was running down the table drain on the southern side of the road near Mr Mallon's mailbox was about waist deep. Mr Sippel went into the Mallons' yard. He linked arms with Ms Mallon and in this way guided her to the main road. They fought the force of the water all the way. From there he walked back to his family. The water continued to flow pinning them in the right hand lane as it rose towards the centre line of Gatton-Helidon Road flowing from west to east.
146. At his petrol station in Anzac Avenue, Mr Warburton had seen the water rising fast and flowing fiercely. A shipping container had floated past him down the street and the water was waist high within his shop. He had never seen anything like this. He had planned to escape across towards the railway line if it became necessary but by now the situation there was worse. The water was flowing at a terrible pace, breaking like rapids over a stream. He ran into his shop to get some personal belongings in an attempt to get to the railway line. By the time he had done that a large surge of water went past the shop, came into the front door and smashed the two front windows inside. Mr Warburton began treading water.
147. There was no power and the water was blocking the daylight. He found himself about eight inches from the ceiling. He thought that he was going to die. He feared that even if he managed to get out of the shop the speed of the water would sweep him away and kill him.
148. In desperation, he dived under water and swam out of the door of the shop. The current caught him and swung him around to the east, smashing his hip into the door jamb. He managed to grab hold of a batten on the front awning of his shop. From there he pulled himself onto the roof and to safety.



149. As the water tore through Grantham, Mr Darlington at his home on Anzac Avenue, saw his two boats, that had been tied securely, swept away. He was returning from the railway yard where he had left his car. The depth and velocity of the water meant he couldn't get back to his house. He waded into his shed. He climbed to its mezzanine floor. He decided he should get his family out of the house. He laid a steel truss from the shed to the bathroom window of the house and escorted his family to the safety of the shed.
150. He called out to his neighbours, Wayne and Ann-Maree Geeves. When he got a response from them they said that they were up to their necks in water. He threw them a rope and they managed to pull themselves across to his shed and to safety.
151. In the meantime, Wayne Lack and his wife Christine, had returned from the general store in Anzac Avenue to their home nearby. They went to the upstairs section of their two-storey house and watched the flood from their verandah. The water kept rising. They saw the water rise two metres in a matter of seconds. He and his wife climbed onto their roof for safety. The water kept rising past the floorboards on the first floor of their house.



152. Ms Spierling had guided her children to safety, racing against the brown wave of water which was rushing down the track to the east. As soon as she was satisfied that the children in her care were safe, she looked back to the west and saw people struggling to run along the embankment. The water had risen by now so that, even on the bridge, it was over her feet. Having reached a point of safety, Ms Spierling then went back towards the approaching flood to encourage the group of stragglers who, she could see, were struggling to beat the wave that would take them.
153. The water filled the cab of his truck as Mr McGuire desperately continued to call for help over the radio and on his phone. Mr Pinkerton, who was on his roof at Gatton-Helidon Road, watched Mr McGuire in his truck. He saw Mr McGuire look up towards him with, as Mr Pinkerton described it, a look of resignation in his eyes. He saw the flood take the truck and spin it anticlockwise and push it to the east when he lost sight of it.
154. Inside the truck, Mr McGuire frantically threw his son, Zac, out of the open driver's side window towards some trees. He called at him to climb. Llync was screaming that she couldn't get her window down. The truck spun around again with the force of the floodwater and now faced west. The cabin of the truck filled completely. Mr McGuire tried to grab his daughter, Jocelyn, but as he did so, the water pulled him out of the driver's window of the truck and swept him against a tree. Unable to swim, Mr McGuire hung there watching 44 gallon drums, a green shipping container and cars washing past him. He didn't know where his family was. He couldn't see the truck or his wife or children. He called out for his son and eventually heard a faint answer. Zac was repeatedly calling for his mother. Mr McGuire encouraged him to hang on and to climb higher. He told him helicopters would come. But the water kept rising and Mr McGuire climbed with it. As he sat in the tree he saw the top of his truck in the distance. He and Zac stayed there, each of them clinging to a tree.
155. Frances and Kenley Arndt had also managed to climb into the branches of a small tree. When they had climbed as far as they could they were still in water up to their waists. There was no telling whether the floodwaters would keep rising. If they did, there was nowhere for the Arndts to go as they could not climb higher into the small tree to which they were clinging. They watched as heavy objects swept towards them. A car and then a shipping container surged towards them and turned at the last moment.



156. Ms Minns had opened up the school as soon as she had seen the flooding from the back of her property. She saw people standing on Victor Street. They appeared to be in shock. Many of them were in tears. Shandy Wilkin and her children were there. Ms Wilkin told Ms Minns that her house had been washed away. People were running up to the school from the railway bridge.
157. Ms Spierling was one of these. She was a member of the Army Reserve and had received first aid training. She identified herself to Sergeant Minns and she began to assist with giving first aid to injured persons. Sergeant Minns also connected with Brendan Shanks, a member of the SES, who began to assist. Jeff Purton, a member of the Rurals, set up his van in the school car park. The power in the area had failed by this stage and Mr Purton was able to furnish lighting for the school by means of the generator in his van. He was also able to use the radio in his van to communicate with Fire Communications and directly with the rescue helicopters which began to arrive.
158. Sergeant Minns continued to receive reports from people who had seen events occurring in the floodwaters including in relation to people being washed away or stranded. He served as a communications hub to pass such information on to those who could assist, including the helicopter rescue team.
159. With his wife, he established a sleeping area for the evacuated people and arranged for the collection of necessary supplies such as blankets, swags, doonas, dry clothes and food.
160. Ms Minns and her husband slept in the school office that night. Ms Spierling rendered first aid through the night.
161. The 000 calls which people in Grantham had been making were having an effect. A helicopter had been attending to the transfer of patients from Kilcoy. The pilot was Mark Kempton. Captain Kempton holds the position of Senior Helicopter Pilot with Emergency Management Queensland Helicopter Rescue. He is highly experienced and is a qualified instructor of pilots and crews. He had worked out of Archerfield for 11 years at the time of the flood. His co-pilot was Darren Parsons. They were attended by Mark Turner, a Rescue Crew Officer, and Ilya Selmes, a flight paramedic. Dr Glenn Ryan, a medical practitioner, is an emergency specialist and was also on the flight. While loading the patients on board at Kilcoy, Mr Parsons received a phone call. A police inspector informed him that a major flooding disaster was unfolding in Toowoomba. The helicopter had been planning to deliver one of the patients to Nambour and the other to Brisbane. Faced with the need to go to Toowoomba they decided to convey both patients instead to Princess Alexandra Hospital. They did this and flew to Archerfield to refuel and to make

plans. The weather was poor and, in the judgment of Captain Kempton, it would be impossible to get to Toowoomba because of the low cloud and heavy rain. By then the crew had received further information about the emergency in Grantham. In particular, they were informed that a fire truck with children on board had been washed away. This was, of course, a reference to Mr McGuire and his family. They were asked to go to Grantham immediately.

162. With the call sign "Rescue 500", Captain Kempton's helicopter lifted off from Archerfield at 4:28 pm. The cloud was low at 1,500 feet and there were heavy showers. They flew below the clouds. En route to Grantham the telephone on the aircraft devoted to tasking matters kept ringing. Each of these calls concerned the need to rescue people from roofs of houses. Upon arrival at Grantham the crew was shocked by the large number of people they could see on rooftops. They were unable to see anyone in the water. They first searched for the fire truck but could see nothing except water engulfing houses, cars and streets.



163. The crew decided to start at the western side of the town and work to the east to identify people in need. In the meantime they had to decide upon the rescue technique they would adopt. They decided to use a rescue collar to winch people aboard. The crew began to work. As the helicopter filled with those they had rescued, Captain Kempton looked for a suitable landing area. He saw a high point on a farm on Lawlers Road owned by John and

Betty Fullerton. They made this their triage centre. They delivered their first six patients to the farm and returned for others. Many of the survivors were injured. They were all cold and wet. Some of them had little clothing. The paramedic, Mr Selmes, remained in the helicopter at first, assisting with settling the rescued people. He then remained at the Fullertons' property with Dr Ryan to attend to those sheltering there.



164. Many times Captain Kempton was directed by people whom he was about to rescue to help other people instead whom he had been unable to see. In this way his attention was drawn to Ms Keep, who was winched up into the helicopter. She was severely distressed. They winched Matthew Keep and others from a nearby roof and brought them to the Fullerton's property. Ms Keep was taken to one of the bedrooms and immediately treated with intravenous fluids.



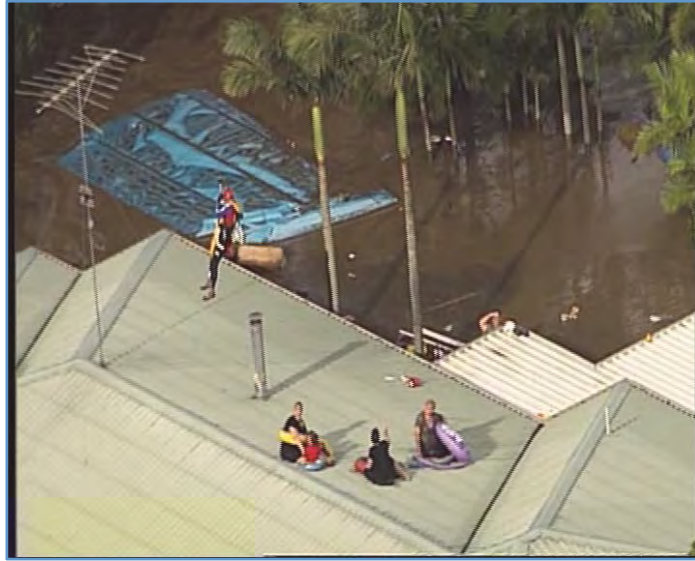

165. Back at Archerfield work was underway to assemble a crew and equipment for a second rescue helicopter. The pilot of this aircraft was Captain Peter Row, an experienced rescue pilot who had worked for Emergency Management Queensland Helicopter Rescue for 10 years by that time. His winch operator was Brett Knowles. Two Rescue Crew Operators, Stuart Wark and David Turnbull made up the rest of the crew. They knew that Rescue 500 needed fuel. This aircraft, whose call sign became Rescue 510, took off at 5:41 pm and flew to Grantham. Captain Kempton was still in the air. He made contact with Captain Row and directed him to the Fullertons' property where they both landed. Rescue 510 took some of the rescue gear from Rescue 500 for use. Rescue 500 returned to Archerfield for fuel. Captain Kempton and his crew had rescued 28 people (and one cat which had entered unnoticed by the crew).
166. At Archerfield Captain Kempton immediately began to work out whether it would be possible to continue rescue work using night vision goggles. The weather was worsening and this was impossible.
167. Captain Row flew over Grantham and his crew assessed the situation before beginning work winching people to safety. They saw many people in the water, some clinging to trees and others on rooftops.
168. The light starting fading and the helicopter was low on fuel. Captain Row decided that as soon as they had retrieved the last person off the roof over which they were then working they would return to Archerfield. Having winched that last person to safety, Captain Row performed a last sweep of the area using a powerful searchlight and spotted a man clinging to a tree. He was surrounded by fast flowing water. Captain Row decided that he had to be rescued. He too was winched into the helicopter.
169. At the Fullerton's property Dr Ryan and Mr Selmes were of the opinion that an elderly lady and Ms Keep were in urgent need of attention at a hospital. When Rescue 510 landed they spoke to the crew and told them of this situation. Because the aircraft was low on fuel it was only possible to take a single patient away. After consultation they decided that the elderly lady's case was not as urgent as that of Ms Keep. The crew carried her to the helicopter and flew to Amberley where an ambulance met her. Rescue 510 returned to Archerfield. The weather had deteriorated further and it was now dark. If the weather cleared up it would be possible to employ persons who were qualified in the use of night vision goggles to attempt night rescues. However, as they waited, the weather remained too bad to fly and at 9.30 pm the decision was made to postpone further work until the morning.
170. Captain Row and his crew had rescued 15 people in the hour and a half available to them.

171. A third helicopter was piloted by John McDermott. It had been tasked to transfer two swift water rescuers to Toowoomba. Mr McDermott was joined by his son, Simon, and by Benjamin Sutherland, a rural fire volunteer fire fighter attached to the Coomera Valley Rural Brigade who was trained as an air observer. As they tried to climb the range into Toowoomba they were met with violent weather and low cloud. Somehow Mr McDermott managed to bring his helicopter into Toowoomba. He had to fly low while avoiding high obstacles like power lines. They landed at Toowoomba airport and dropped off the swift water rescue team. In Mr McDermott's judgment they needed to leave quickly if they were to avoid the weather grounding them. They knew that there was a great need for helicopter rescue in the Lockyer Valley so they lifted off and headed back. As Mr Sutherland described it, while they were descending from Toowoomba into the valley they were experiencing conditions referred to by pilots as "the Hand of God". These were violent up and down drafts that shook the aircraft. Mr Sutherland and Mr McDermott decided that, having regard to the dangerous conditions, it would be advisable to have a second observer. Earlier they had dropped off Mr McDermott's son, Simon, at Withcott; now they picked him up and flew to Grantham. Like the earlier helicopters, they performed a primary search of the area to identify people in need and to make judgments.
172. Not equipped with winch gear, this helicopter served as an observation platform to identify those in desperate need so that the winch equipped helicopters could attend to them.
173. They landed after dark at Withcott Primary School lighting the way to permit Rescue 510 to follow them safely. Their work did not end then. It was necessary to engage in planning and preparation for the rescue work that would begin as early as possible the next day.
174. As soon as he had been brought to the Fullerton's farm by Rescue 500, Mr Keep frantically told Emergency staff that his daughter Madison might still be alive in the house. He was told that, because of the dangers and risk of injury, Emergency staff were not permitted to enter houses and that their priority was to rescue people off the roofs of houses. In a rage, Mr Keep immediately ran back to the flood waters.
175. The Besleys saw the water go down and were finally able to climb down from their position and walk to Gatton-Helidon Road.
176. Sitting in the house in Harris Street, Raymond Van Dijk and his friend Daniel Moore, having been victims of the flood, now became rescuers. They became worried about people in the houses nearby. It was dark. Mr Van Dijk's next door neighbours were an elderly couple. Mr Van Dijk and Mr Moore used long compressor hoses as ropes and fashioned a cable from their house to the next door house. The front door of their neighbour's house had been smashed open and the water had driven the furniture inside against the back door. One by one they brought Michael, who was 84, and his wife Kerry, who was 66, back to Mr Van Dijk's house. They were wet and in severe distress. But for Mr Van Dijk's and Mr Moore's efforts, it is likely that they would have died.
177. Mr Van Dijk could hear other people calling for help. Keeping his nerve, he got his canoe and paddled across to the house across the street. A woman was there with her three children sheltering on top of a bunk, all of them crying with fear.
178. This was Tina Smrecnik and her children. She was living on Harris Street with her daughters Jessica, aged four, Hayley, aged seven and her partner Mark Sutton and their baby daughter Torah aged six months. At some time after 2 pm, Ms Smrecnik began to receive text messages inquiring about her safety. Puzzled, she looked outside and saw that water was moving up the street from Sandy Creek. Mr Sutton went downstairs to turn off the electric power. The water was past his ankles. By the time he returned, it had risen to the level of his shorts. The water was now flowing strongly along the street. Ms Smrecnik saw a utility belonging to a neighbour being washed down the street by the force of the flood. Debris was being washed away and making loud noises. Ms Smrecnik put her daughters into their top bunk for safety. She dialled 000. She was now worried to the point of panic. She repeatedly

called 000 and was finally advised to climb onto the roof. She was told that helicopters were coming. Together, she and Mr Sutton broke an opening into their ceiling space and passed the children into the ceiling cavity. By then the water was entering the house. Mr Sutton recovered necessary items from the house and brought them into the ceiling cavity. He climbed onto the roof to survey the situation. After an hour or more, the channel 7 helicopter appeared and, some time later, an emergency services helicopter flew overhead. As the evening came, the water began to recede and the family moved back down into the house. Some time later, Mr Van Dijk and Mr Moore appeared in the street, pulling their canoe behind them. Mr Van Dijk warned that more water might come. Ms Smrechnik and her children were placed in the canoe and Mr Van Dijk and Mr Sutton escorted them to Mr Van Dijk's home, where they joined a number of other people who had been brought to safety.

179. Mr Keep had run back to the area near his house. He crossed the railway lines and entered the water, still flowing powerfully eastwards. He swam towards his house and, as he came close to it, began to scream out for his daughter. As he heard her voice he was washed past his house.
180. Johnathon Klaassen lived on Gatton Helidon Road. He was a 23 year old man. At about 3 pm he received a phone call from his brother, David, asking him to come to an address at Lawlers Road. The road was flooded but he walked the distance to meet his brother. Mr Klaassen began to phone people he knew in Grantham to find out if they were safe. He rang Ms Spierling but could not get through. He rang others. He and his brother walked up Lawlers Road and then up the railway tracks to a point where they could see the Spierling residence. At a point about level with Sorrenson Street they decided it was too dangerous to continue. As they began to walk back to Lawlers Road they met Mr Keep. He was in a shocked and excited state. He told them that his daughter was still in his house. Mr Keep got into the water and they saw him washed away immediately. Mr Klaassen gave his phone to his brother, David, and took his shirt off prepared to dive into the water to assist Mr Keep. Mr Keep shouted at him that the current was too strong and to remain where he was. Mr Klaassen did not do that. Instead, he ran about a 100 metres to the west up the railway tracks and got into the water at that point. He then allowed the current itself to sweep him towards the house that Mr Keep had pointed out to him. He reached the house and could hear the voices of children screaming from inside. He entered the house and saw Madison sitting on a couch wedged up against the wall. The water was a metre high. She was crying. She was wet and cold. He picked her up and attempted to calm her and took her outside. He could then hear the voice of another child coming from a back room.
181. Mr Keep had managed to regain his footing and get out of the water. Like Mr Klaassen he also ran upstream and entered the water, allowing it to sweep him towards his house. He was screaming out for his daughter. He met Mr Klaassen who told him that he had heard the voice of another child inside.
182. Mr Keep went inside the house and found his son alive in the shower next to the main bedroom. He picked him up and joined Mr Klaassen on the back portico. A helicopter arrived soon after and winched them up and flew them to safety.
183. After leaving his son and daughter in safe hands, Mr Keep again returned to Railway Street to give any further assistance he could. Johnathon and David Klaassen saw him go and joined him. Together they found an elderly lady in a house at Sorrenson and Railway Street. She was too old and frail to move. They ran to the highway where they found some fire officers. Mr Keep told them that they had found an elderly lady in a house and that they needed to get her out. Again he was informed that they could not help. As Mr Keep put it, he "then told them they had to help or it would be on". The fire officers, Mr Keep and the Klaassen brothers got into a truck and recovered the elderly lady.
184. Ms Sparkes and her baby were also rescued by helicopter from the roof of the house on Railway Street. A crew member of the helicopter was winched down to the roof where he strapped a harness to Ms Sparkes' body. Her

neighbour Kristy Kunde, who had earlier been swept away by flood waters and had managed to scramble to the stairs of Ms Sparkes' house, now handed Ms Sparkes' baby, Sophie, to her. The crew member said, "You're holding onto her for her life." Ms Sparkes has explained that she "snapped out of the emotional part and really focused on the fact that I had to hold her". The helicopter in which she found herself continued to hover over the house as the others were brought up one by one. It flew to other places and more victims of the flood were winched into its belly, from houses and from trees.

185. Frances and Kenley Arndt were also rescued in this way. As they held onto the top part of a small tree, they heard people on a roof nearby. The foliage of the tree meant that they could neither see these people nor be seen by them. They began to call out and learned that these were Justin Otto, his wife and grandson. Some time later, Ms Arndt heard a helicopter overhead. She knew it would be unable to see her through the leaves and branches of the tree, so she shook a nearby branch, breaking it and losing her hold. She fell into the water which was still too deep to stand. She managed to climb back into the tree. The helicopter could see the Otto family however, and hovered overhead to rescue them. Justin Otto instead signalled that he and his family were secure but there were people in the tree who were not safe. In this way, the crew of the helicopter were alerted to the position of the Arndts and a crew member descended into the water and swam over. Mr Arndt insisted that his wife be attended to first. The crew member secured a harness to Ms Arndt and the crew of the helicopter lifted her into the aircraft. The swimmer returned and picked up Mr Arndt.
186. He was utterly exhausted. He believes that if he had had to cling to the wreckage for another 10 minutes he would have had to let go. He was unable to move. The crew and another victim, John Mahon, had to pull him into a secure position.
187. Frank King could also not be seen by helicopter crews. He saw people being rescued from rooftops but had no way to alert them to his own presence. It was getting dark now. The water level was dropping quickly but there was no way of knowing whether or not this would be followed by further flooding. He decided to get down from his tree. He found he could just stand. The water was up to his shoulders. He forced his way across the flowing water onto Railway Street where he heard his son, John, call out to him. Until that moment, he did not know whether John was alive or dead. He was mentally and physically exhausted. John waded through the waist-deep flowing water to his father and, together, they slowly made their way home.
188. In January 2011 Bradley Wright was an inspector of police attached to the Special Emergency Response Team. He had experience in emergency assistance having performed a relieving role as a Disaster District Coordinator during the 2009 Ingham floods. He had participated in the development of national emergency management response policies and has performed duties at a high level in the Police Operations Centre.
189. On 10 January he was the Acting Superintendent of the Specialist Response Branch. Just before 4 pm he was informed that there had been a severe storm in Toowoomba and was asked to consider what resources the Specialist Response Branch might be able to provide to assist local police. He informed Acting Chief Superintendent Brian Codd that he and six of his staff were available. Just before 6 pm Acting Chief Superintendent Codd directed Inspector Wright and his team to go instead to the Lockyer Valley. He assembled his team and they collected the necessary equipment and drove to the BP service station on the Warrego Highway at Gatton. Acting Inspector Symes had been appointed Police Forward Commander and met Inspector Wright and his team there.
190. Together they made attempts to secure the services of a helicopter but were told that this was not going to be possible until daylight. Inspector Wright then decided that he had to attempt to get into Grantham by road. They drove towards Grantham and saw the devastation that the floods had caused. Some kilometres short of Grantham the road was blocked by part of a building, a shipping container and other rubbish. A 40 tonne end loader was there. Crews were using this to try to remove the debris. This was an end loader that was normally used at a

quarry. Allan Payne, Peter Van den Elsen, Christopher Forden and Iain Gray, who were employees of the quarry, were moving with the end loader towards Grantham to see what they could do to help. Inspector Wright arranged to meet them closer to Grantham.

191. He and his team arrived outside Grantham at about 9.30 pm. The road could take them no further. It was still raining heavily. There was no power and visibility was low. He could see that houses had been damaged. There was debris including aircraft and vehicles which had been overturned. Towards the centre of Grantham he could see that the water was deeper and still flowing rapidly.
192. There was a small number of Queensland Fire and Rescue Service officers and some uniformed police officers at the point where Inspector Wright had stopped. They told him that they had been locating and bringing people out and the police were transporting those rescued to Helidon. There were no flood boats available.
193. Inspector Wright saw a fire truck just off the highway. As he later learned, this was Danny McGuire's truck. Somebody told Inspector Wright that there were three bodies in the truck.
194. Inspector Wright spoke to them about the state of the bridge over Sandy Creek. They decided to move forward to assess what damage might have been caused to the bridge. If it was possible to cross then they would do so. The QFRS officers made a number of crossings by wading across the bridge. It appeared to them to be intact. Inspector Wright directed two of his own officers to move forward, with the end loader which had arrived, to assess the position in Grantham. At this point Acting Chief Superintendent Codd informed him that he was to take charge of the response and of the tasking of the Public Safety Response Team officers who had also been directed to attend under Acting Superintendent Stephen Dabinett.
195. Inspector Wright saw lights being flashed in some of the houses nearby. Three of his officers equipped themselves with lighting and began searching the nearby houses, wading through the water.
196. Inspector Wright was not a local. He was unfamiliar with Grantham. But he could see that there were many houses set well back from the road on the outskirts of town and that the flooding was over a wide area. At night he had no means to identify where houses might be or to locate them.
197. Nevertheless, the teams under his control began to search the town. People they found were rescued and brought back to him. Inspector Wright then directed Sergeant Andrews, who had been attached to the Ipswich Tactical Crime Squad, to coordinate the evacuation of rescued persons.
198. Inspector Wright received information that there were about 20 people trapped on a roof at 6 Harris Street and that the roof was at risk of collapsing. Harris Street had not yet been entered by any search crews. When the end loader crew had returned with rescued persons from the centre of town he directed the crew to attempt to access Harris Street. They were able to do so and brought stranded people back out in several trips. They also found people trapped in a number of other houses and these were also evacuated. These rescues from Harris Street took several hours.
199. During this time police from Gatton attended and provided rudimentary maps of Grantham to assist in the search and rescue. Slowly, as information came from search teams and from local police, a search strategy was formed and executed. This strategy involved the area to the south of the railway line from Sorrenson Street to Armstrong Road and Harris Street as far as possible. Instructions were given to officers to search all the areas as best they could in the darkness but to focus on finding people who were alive and required rescue. Information on any dead persons who were found were to be provided to Inspector Wright so that that could be attended to later.
200. Just before midnight, Inspector Wright requested another end loader and within a short time this arrived.

201. After midnight, Inspector Wright reviewed the search strategy together with the QFRS Controller. They decided to have officers who had searched the town confirm that the search was a complete search. If this could not be confirmed, then the crews would be sent back to clear all areas again.
202. Sometime later the end loader crew advised him that they were unable to travel any further along Harris Street as the water levels made it impossible. Further properties in that area could not be reached. It was obvious that the only way to check the more outlying properties and to evacuate the school itself, where there was a large number of people, was by helicopter. However, just after 1 am Inspector Wright was informed that two Blackhawk helicopters and two Sea King helicopters would only be available for that purpose in daylight.
203. The Public Safety Response Team officers, the QFRS officers and Inspector Wright's own men then conducted a confirmation search as far as that was possible. This was completed at 3 am.
204. At 3:30 am Inspector Wright spoke to Acting Inspector McDonald at Toowoomba and told him that his team would remain onsite and could manage their fatigue until about midday. He told Acting Inspector McDonald that a strategy had to be formulated for the next day which had to include a search for deceased persons.
205. As the early morning wore on, Inspector Wright was informed that 25 police would leave the Police Academy at Oxley at 8 am to take over from Inspector Wright's team. Inspector McDonald called from Toowoomba and advised that six police crews would be leaving Toowoomba at 6 am to assist. Inspector Wright called Sergeant Minns at the Grantham School just after 5 am and they discussed the evacuation of the school and the surrounding houses. He then drove back to Helidon and attended the evacuation centre there. A Care Flight doctor and rescue helicopter paramedic were at the evacuation centre.
206. A little later that morning Inspector Wright reported upon the situation to the Minister, the Commissioner and the Deputy Commissioner.
207. He then received information that the number of people at the school were more than had been thought. It had been intended to evacuate them by helicopter. However, just after 9 am on 11 January Inspector Wright learned of flooding crises developing at Laidley and Forest Hill. It was likely that the entire towns would require evacuation. He shifted his focus to the evacuation of known persons from Grantham, the establishment of security around the town to prevent entry from the outside and the development of a strategy to begin search and recovery of the dead.
208. Throughout this time he was receiving information about people who might be at risk. This included reports of people still on roofs. Some of this information was incorrect but all of it had to be checked and this took up time and precious manpower. A number of serious cases had to be taken quickly to Gatton Hospital under police escort. More storms were forecast. This meant that tasks had to be performed as quickly as possible while conditions permitted.
209. While all of this was being done it was important to maintain a record of persons, of their whereabouts and where they had been taken. Lists had to be prepared by somebody and maintained. Thus, Sergeant Minns had prepared a list of persons at Grantham School. Persons adjacent to the school had their names taken by officers under Inspector Wright and this list was then added to the school list. Persons at the Helidon evacuation centre were listed by the local priest, Father Marcus. Those evacuated from Grantham were listed by Sergeant Andrews. All of this had to be coordinated by Inspector Wright.
210. Finally, at 4:45 pm on 11 January, Inspector Wright was able to hand over control to Acting Inspector Russell Robson who had arrived with a number of his staff. Inspector Wright and his fellow officers had been on duty continuously for over 24 hours.

211. In order to allow such assistance to be given in Grantham, much unseen work was also being done by police. At the time, Stephan Gollschewski was the Assistant Commissioner, Southern Region, and was based in the Toowoomba Regional Office. He had the overall responsibility for the response by police to the flooding events both in Toowoomba and the Lockyer Valley on 10 January. He established a Major Incident Room to support the operational response. The log sheet kept for the operation reveals in dense detail the many, many tasks that were performed from the commencement of the MIR late on the night of 10 January. The first few entries concern the receipt of information about local weather, forecast weather and road closures. At 5:21 am on 11 January a request was put forward for counselling services to be made available at the Grantham evacuation centre. By 7.30 am, four divers had been assembled and arrangements had been made to fly them by helicopter to Grantham. Just before 9 am a decision was made to evacuate Forest Hill and Laidley. Forty police were coming by helicopter and by bus to those two towns. Landing zones were identified at Laidley and at Forest Hill and, at 9.05 am, two Sea King helicopters were waiting at Oakey ready for use. In the meantime, Inspector Isherwood, who was at the scene, was on the radio seeking further crews and a food drop. Two Black Hawk helicopters flew to Forest Hill and landed at the cricket ground. The two Black Hawks and a Sea King had begun ferrying people from Forest Hill to Gatton University. Rescue 510, with Captain Row, which had worked the day before, was also taking people from Grantham to Gatton University.
212. A report came from Oakey Hospital advising that there were 72 aged care patients there who required evacuation. This was arranged. There was flooding at Jondaryan. People had been evacuated to the Town Hall. People at properties neighbouring the creek were concerned and had requested evacuation.
213. And so the running sheet continues until it ends on 8 February 2011 with item number 561.
214. One by one the survivors were saved or saved themselves. The Besleys carefully picked their way to Gatton-Helidon Road through water that was still deep. A car carrying a driver and passenger stopped to pick them up. It was a ute that was heading into Grantham to reach the passenger's mother-in-law and four children who were still trapped on a roof. Even so, the passenger insisted to the driver that the car stop, back up and pick up the Besleys.
215. Others, including Michael Darlington in Anzac Avenue, were picked up in the bucket of the low loader. Three of these machines were put to use in this way on the night of 10 January. One had come from the quarry at Helidon and the other two were owned by the Council.
216. On 10 January Mark Kelly was the District Inspector for the Toowoomba District and was on leave. Having heard reports of the flooding, he called the Toowoomba District office on the morning of 11 January and went back to work.
217. He was designated to assist Acting Superintendent Schafferius. On the morning of 12 January he arrived at Grantham. As he described it in evidence:
- “... you started to see the carnage, cars turned on their side, ... unless you see it for yourself widespread damage is really indescribable.”
218. He established his command post at William Street. In the beginning this was just a police vehicle to act as a command vehicle. A team of 32 search coordinators had been assembled. Search coordinators are persons who have undertaken a course in search and rescue which is credentialed to a national standard. They undergo rigorous training and must pass examinations to qualify.
219. In the case of Grantham, the search was to be done on foot, from the air and also with machinery. Machinery had to be used because in some areas the debris was so thick and heavy that the only practical method to search it was by the use of machinery to move material.

220. Superintendent Kelly, as he now is, has explained that the international standard for searching expects a detection rate of 80 percent. The search at Grantham achieved a detection rate of 98 percent.
221. Of course, it was not only Grantham which was the subject of his search. An area of about 660 square kilometres had to be covered. This included 131 kilometres of creek line.
222. The Army was called in. Almost 100 soldiers arrived from Gallipoli Barracks at Enoggera on the morning of 13 January. A little later about another 100 arrived as well as an engineering group which brought equipment to assist with the search. In addition, divers were deployed in Lockyer Creek. In this way the creek between Spring Bluff and the Brisbane River was searched three times.
223. The search area was broken into sections from Postmans Ridge to Helidon, Helidon to Grantham, Grantham to Gatton, Gatton to the Brisbane River and the Brisbane River to Moreton Bay. The Grantham township and its immediate surrounding area was itself broken into 37 sectors. Superintendent Kelly consulted with the search coordinators who gave him advice. Superintendent Kelly then directed soldiers from the Australian Army, members of SES and police into groups under team leaders to search each sector. After reporting back, and with the benefit of information gained from the first search of a sector, a new plan would then be formulated based upon this new knowledge and a second team would then be sent to search the same sector. Thus, a search was repeated with fresh eyes and minds being applied to the same area. In the case of open fields, multiple teams would be deployed. Superintendent Kelly explained that the probability of detection increases the closer each searcher is to another one standing nearby. The slower the searchers move the more likely they are to find something.
224. Superintendent Kelly explained in evidence that, as one incident demonstrated, it is only by such repeated and meticulous searching that confidence can be obtained that a search is complete. The last person found in Grantham was in a house in Harris Street. This happened on 17 January. The property had been searched at least four times. Superintendent Kelly went to the location and was shown the body. He said that it was necessary to be 30 centimetres away from the body to be able to see it such was the effect of the flooding, the debris and the mud.
225. In order to attend to the searches in this way it was necessary to exclude anybody from entering the town. Locations were identified on the main roads at which road blocks could be placed safely to achieve this.
226. The whole area was, of course, full of unknown dangers. There were risks of electrocution from power lines and from solar power plants. There might be chemical spills or asbestos. There was danger from the broken buildings and washed up articles. Nevertheless, from the first day police were instructed to go inside premises to check, in particular, that there was no living person in any structure. For this reason even roof cavities had to be checked in case there was somebody unconscious there.
227. The great fear was that somebody would be missed. Superintendent Kelly also believed that it was important to ensure that when residents were permitted to return to their homes that there was no prospect of their finding a corpse that had been overlooked. The search was not easy. A dead person was found on 12 January in a house. Another was found in a field on 13 January. On 14 January somebody was found on the northern side of the railway line. Nobody was found on 15 January. On 16 January a person was found in a house that had been searched a number of times before. On 17 January a body was found in Harris Street, as I have described earlier, in a place that had been searched many times.
228. It was considered to be unacceptable to allow the possibility of bodies being swept up by earth movers along with debris and dumped like rubbish.
229. For these reasons the searches went on and residents were excluded from their homes for what felt like an intolerable period of time.

230. On 24 January 2011 Superintendent Kelly reported that he expected that the search of Grantham would be finished on that day. In other areas the search had to go on for much longer.
231. The flooding in Toowoomba and the Lockyer Valley on 10 January 2011 killed 21 people, 12 of them in Grantham. It was one of the most deadly natural disasters ever to hit Queensland.

Chapter 2: What now?

1. No description can capture the violence of the flood, the speed and the noise of the water that many witnesses described, the fear of death and the horrific experience of seeing the death of one's child, or father, or mother, or sister or friend. Nor can it capture the anguish that has been, and will continue to be, endured.
2. The health of many survivors has been permanently injured. The heartache experienced by Mr Daniel McGuire and his only surviving son has damaged them in a way that a lifetime of treatment might not repair. Mr Frank King has described how, even now, four years later, his arms still hurt from the effort of holding on for his life. Ms Besley's hip was broken. Mr Van Dijk was injured in his rescue work. Everybody involved has suffered harm.
3. As the witnesses each came forward to give evidence, and I do not exclude the professionals who came to the town to rescue, to care and to search, it was plain that every single one of them was emotionally overcome by having to remember and retell. Their pain and distress was obvious. Every single one of them has been changed by the experience.
4. But the horrors of that day also brought forward something else. In the course of giving evidence about dreadful things, many witnesses made reference, always in a casual and indifferent way, to acts of bravery of their own and of others. In some cases, in my opinion, these amounted to acts of real heroism.
5. The first witness to give evidence, Ms Lisa Spierling, gave the following evidence:

“Did you run with Ilsa all the way down to the railway line? --- Right towards – just before I got to the bridge, Mr Day ended up taking her off me, and that's **when I turned around and went back** to yell at some of the large people who weren't running fast enough.

This was some adults who were behind you? --- Yes.”
6. Ms Spierling attached no significance at all to her act of bravery in turning towards danger to encourage others to safety. Nor did her commitment end there. There being no paramedic at the State School, Ms Spierling applied her Army Reserve first aid knowledge to attend to the injured through that night while longing to be with her children.
7. Something that Mr King did was remarkable. As I have described, he was literally hanging on for his life as the water and the heavy floating objects tried to kill him. He was not a young man but he had found himself, in just a few minutes, changed from a man strolling with his son into a struggling, half-naked drowning man. It was in those circumstances that he said that this happened:

“I did see onto the railway line. I was alerted. I wasn't deliberately looking at the railway line but I was alerted to people coming past me. I saw Shandy, Wilkins as she was then, carrying a child and she had a phone to her ear and she had several children with her who were crying. I saw Lisa Spierling, Robby Wilkin and Jimmy Wilkin going along. I saw some other people who I wasn't really aware of who they were. **I did yell out encouragement to them to keep running. I don't know whether they heard me or not** ... at that stage the water was so vicious, I had my head down and was trying to protect myself ... you'd get a few seconds reprieve and then the next wave would hit you.”
8. As I listened to Mr King give this evidence, I was unable to grasp how a man in that predicament found the grit and spirit to give encouragement to others in danger.

9. Captain Kempton and Captain Row, who flew the rescue helicopters, have both told how, on a number of occasions, people they were about to rescue instead directed their attention to others who, they judged, were in greater need than they themselves. One of these people was Justin Otto, who directed a helicopter to Frances and Kenley Arndt, who were hanging invisibly to a tree. Having regard to the state of exhaustion of Mr Arndt, there can be little doubt that Mr Otto's act of selflessness saved his life. And it was very noteworthy that while at the limit of endurance, Mr Arndt still insisted that it was his wife who should be rescued before him.
10. Mr Raymond Van Dijk and his friend Mr Danny Moore ventured into the flooded darkness and into broken houses and unknown dangers at a time when they believed another flood could be imminent and that it might suddenly appear out of the night. In this way they brought over twenty people to safety.
11. Mr McGuire and his wife, Ms Llync Clarke-Jibson, remained in Grantham at a time when it was Mr McGuire's view that it would be wiser to evacuate. They worked at an intensity far beyond that which any duty required of them and they did so in order to serve and protect their friends and neighbours. As a result of this devotion to duty, Mr McGuire and his son have lost everything.
12. It was not only adults who exhibited courage that day. Ms Wendy Hodda was responsible for her 10 year old son, John, as well as her daughter's three children, aged seven, five and two. To save their lives she had to get them onto the roof but this was not possible without the help of another person. Despite the fear that must have been almost overpowering him, John stayed steady and alert and worked together with his mother to save the lives of the younger children, an act of true bravery.
13. The pilots and crews of the rescue helicopters performed their duty in flight conditions that put them at risk. Because of their coolness and exceptional skill, they were able to begin the work of rescue with a speed of response and an effectiveness that was astonishing. I observe that at the time that Captain Kempton was attending to those in peril at Grantham, he was obliged to neglect his own home, which as he knew, was at that very time being flooded in Brisbane.
14. To this catalogue of brave people must be added the officers of the Queensland Police Service, of the Rural Fire Service, of the other Fire Brigade members and the members of the State Emergency Service who rushed to the town as soon as they possibly could and in darkness, in pouring rain and through flood and in entirely unfamiliar surroundings went straight into danger and worked through the night and the next day to bring people to safety.
15. These are merely the cases of bravery that have emerged directly in the evidence. What they demonstrate, of course, is that there must have been many other such acts of selfless courage throughout the course of that day and the night that followed and which have not been documented and never will be.
16. The bravery and selflessness of the people of Grantham was just a matter of routine on 10 January 2011.
17. It is unjust to make comparisons between acts of courage. But, the statements which have been tendered and the recollections of the witnesses giving oral evidence have brought forward actions that were heroic in the real sense of that word, that is to say, they were acts which involved people deliberately submitting to imminent risk of death in order to save others.
18. Mr Matthew Keep was one such man. In the face of the refusal of officials to go into the town to search for his children, Mr Keep returned alone to the danger from which he had just been saved and plunged once more into the flood to save the lives of his son and his daughter.
19. In this he was helped by the exceptional courage of Mr Johnathan Klaassen, a young man who, seeing Mr Keep's frantic efforts to save his children, and after seeing him actually swept away by the rush of water then himself leapt

into the cataract, ignoring Mr Keep's cry to stay away. By taking this awful risk, he was able to find and save Madison Keep and to discover that her brother Jacob was also alive. By doing these things, Mr Keep and Mr Klaassen saved the lives of two children.

20. Mr Keep and Mr Klaassen did not stop their efforts there. Having rescued Mr Keep's two children, they and David Klaassen went back yet again to see if others needed their help and secured the safety of another person, an elderly lady.
21. The actions of Mr Robert Wilkin and Mr James Wilkin were also conspicuously courageous. It will be remembered that, after warning his neighbours about the approaching flood from the south, Robert Wilkin had placed his family and his neighbours in his car, ready to evacuate them, but then turned back towards the flood, which he knew was coming fast, in order also to save Ms Spierling and her children. Having taken all of these people to the relative safety of the railway embankment, Robert Wilkin then returned to the advancing flood. He joined his brother James and together, keeping their nerve, they made a plan and hooked up Robert's 18 foot motorized tinnie to his truck and drove it down to Railway Street. There they helped two adults and two children run to the safety of the railway embankment before the water finally reached them and their boat. James Wilkin has said that he thought the flood which then engulfed them was so strong they would die. Still, they brought another neighbour into the boat before Robert started the engine and steered it to the fence on Railway Street adjacent to the embankment. Mr Brendan Keep and his mother, Michelle, had been swept onto that fence. As Robert controlled the boat, James pulled Brendan and Michelle into it. Michelle had been forced to let go of the fence by the pressure of water and she would have been dragged away to, probably to her death, by the current but for what the Wilkins brothers did that day at great risk to themselves. Robert manoeuvred the tinnie to the railway embankment and they all fled along the track to safety.
22. The things that happened, and the things that people did, their courage as well as their suffering, all demand that some meaning be given to that day. The deaths in Grantham cannot be permitted to become a mere statistic. This raises the question, what significance can be attributed to this catastrophe? Can anything of value be taken from it?
23. This calamity can only produce something rewarding and constructive, something of meaning in our lives, if it can be used for the benefit of the people of the Lockyer Valley and the people of Grantham in particular.
24. It is the opinion of some that the only way to prevent such a catastrophe happening again is for nobody to live in or nearby Grantham ever again. I do not share that view. The part of the Lockyer Valley that can be affected by dangerous flooding is huge. It is not only Grantham itself that can be devastated by flooding but also many square kilometres around it where people live and work whatever the weather might bring.
25. There are many areas in Queensland and, indeed, in Australia in which there is always the chance of dangerous and destructive floods or bushfires or storms. But people do not, for that reason, quit those areas. They are merely reasons to study, to learn and to prepare. That is what people in such places do as a matter of course. Storms, floods and bushfires cannot be prevented. But loss of life or property can be prevented or, at least, mitigated.
26. In my respectful view, just because a flood could one day strike Grantham again is no reason why anybody should leave the area. But that can only be so on one condition.
27. The condition is that those who decide that they will live there must accept that, in doing so they necessarily undertake a duty to themselves, to their children, to their other dependents, to the animals they keep, as well as to the generations which will follow them as future residents. The duty is to look at the facts with cold objectivity; that is to say, without any emotion or prejudice. If people decide to continue to live there and, by doing so, indirectly influence their descendants and others to do the same in the future, I believe that that decision morally obliges them to understand their environment so that people do not die out of ignorance.

28. Having regard to the state of knowledge in 2011, nobody could have expected or predicted the flooding of Grantham that happened. But that can never again be true for the future.
29. I think that life saving wisdom can only come if the facts that explain the flood of 10 January 2011 and the deaths of 12 people are studied, candidly and fearlessly, to learn and to prepare.
30. In my respectful opinion, the evidence can leave nobody in any doubt that the people of Grantham have the character and self-reliance that can safeguard and sustain them through any catastrophe. The evidence has also shown that they also have the judgment and the wit to be able to make preparation, together as a community and as individuals, to meet any tribulation that strikes them. I believe that, if the people of Grantham and the Lockyer Valley are prepared to analyse dispassionately the evidence obtained by the Commission, and which is summarised in this report, they can decide upon steps to ensure their own safety and the safety of those who depend upon them - whatever the future might bring.
31. This Commission of Inquiry was established by the Queensland Government to investigate the causes of the flooding in Grantham, to discover why it happened and how so many people died and why so many have suffered. A great deal of work has been done by many people to examine the causes of the flood. No effort has been spared to make sense of the facts and to unravel cause and effect. The Government placed no restraint that could affect the success of this investigation. No arbitrary time limit was placed upon me or upon any experts. The experts engaged by the Commission have therefore been able to undertake a thorough and painstaking examination and analysis of every single fact and possibility, even those that might, as a matter of first impression, have no merit.
32. Not only have I had the assistance of such experts and of the Commission staff who have searched out all the possible relevant witnesses, I have also had available the thousands of files compiled by the Queensland Police Service which formed Taskforce Galaxy to investigate the flood.
33. In addition, I have had the indispensable help of counsel and solicitors who appeared for the parties at the hearing and whose own work at the hearings and afterwards has resulted in valuable submissions that have enabled me to understand the evidence better.
34. The product of all of that effort is now in this report so that the people of the Lockyer Valley and, in particular the people of Grantham who have been affected by the flood, can make a clear assessment for themselves about the causes of the flooding.

Chapter 3: Was the flooding “unprecedented”?

1. Experience shows that an event like the Grantham flood cannot be understood in isolation from its surrounding circumstances and, in particular, in isolation from the history of the people who have lived there.
2. The evidence of witnesses has established that the severity of the flooding on 10 January 2011 was unprecedented in living memory. It was a flood which was different from those which had been frequently experienced by residents of Grantham past and present. The difference was not only in its severity. It was also different in the volume of water which swept through and over the town and the direction from which that water came.
3. The expression “living memory” suggests a very long period. But in fact it only covers a relatively short period of time. Many residents of South East Queensland, including those in Grantham, can remember the widespread flooding of 1974. That was only 40 years ago. Recollections of events before that are more difficult to find although one witness gave evidence of historical family recollections which go back as far as the flood of 1893.
4. The apparently unprecedented character of the 2011 flood has given rise to concern and also to deep suspicion among residents of Grantham as to what the possible explanation for the flooding might be. The apparent absence from recorded history of any similar flooding has suggested that neither weather patterns nor the surrounding topography of the land could possibly furnish the explanation. The unique character of this flood has raised the possibility that something new, something that has changed in recent years, must have been the real cause. That is a natural line of reasoning and has given rise to a theory that an embankment, or several embankments, at the Grantham quarry caused the flooding or, at least, increased its severity to a death-dealing level. But, like any theory formed in a preliminary way, it must undergo testing and it might prove to be wrong after a thorough investigation.
5. The first step in most investigations, it seems to me, is to examine the history which preceded the event being investigated.
6. A study of the history of the Lockyer Valley and of Grantham itself reveals that a flood of this kind and of this severity is not unprecedented at all. There was a flood like this one, and perhaps worse than this one, in 1893. The effect upon Brisbane of the great flood of 1893 is well known. Less well known has been the effect the flood had on the area between Toowoomba and Ipswich and on Grantham in particular.

History of Grantham and the railway line

7. White settlement began in the Lockyer Valley only in 1841. A sheep station, named “Grantham” by its first owner Gershon Mocatta, was established in that year. It was a property of 30,000 acres with a grazing capacity of 8,000 sheep. Mocatta had moved his stock from Bathurst to Grantham in September 1842.
8. The first settlers, who were of British stock, were followed over the next 20 years by German immigrants who settled in what became Marburg and Minden and other surrounding areas. Laidley Cemetery, for example, evidences people called Arndt, Aischke and Sippel lived in the Lockyer Valley over one hundred years ago. Near Grantham they also settled at Mt Sylvia, Mt Whitestone, Ma Ma Creek, Ropley and Blenheim. Gatton was becoming established by the growth of businesses that serviced the local agriculture industry. A railway siding was established near the Grantham sheep station to service it. In 1868 the government established reserves of land for public purposes. It was at this time that land was reserved for public purposes in Gatton and Laidley.

The Flood at Northbrook (Fernvale).

Mr. F. T. Russell, a 3rd class passenger who, about eight months ago, purchased an...

The Late Floods in the Lockyer District.

As was feared, the receipt of news from various parts of our district (says the Lockyer War of Tuesday) brings with it a pitiful record of the damage done on Friday by the floods.

The same paper of Thursday says:—As further particulars come to hand and further observations are made, the severity of the floods over the Lockyer district become more apparent.

Lockyer Creek in the Laidley and Forest Hill districts made all the difference, though Laidley Creek and Sandy Creek have in themselves done a good deal of damage.

Advertisement for O. SUMMERS, AUCTIONEER, LAIDLLEY. Includes details of property sales and business assessments.

9. The government also arranged for land sales in 1886 with allotments between the Toowoomba Road and the railway line west of Sandy Creek. By then, a number of small businesses were already in existence in Grantham including a post office, fruit shop, hotel, blacksmith shop, a butcher and a grocer.
10. Indeed, when the siding was built in what is now Grantham, it was named "Sandy Creek". It was only some time later that the name "Grantham" came to be used in relation not only to the original sheep station established by Mocatta but also to the growing settlement. A platform was added in 1875. Sheep yards were added in 1882, and a goods shed and mailbag post erected in 1884.
11. In its edition of Saturday, 25 February 1893, the *Ipswich Herald and General Advertiser* newspaper reported that on Friday, 17 January 1893, a flood had swept through the Lockyer Valley. I have emphasised some parts of the report below that I think are particularly relevant and important:

"From Gatton to beyond Murphys Creek may be said to be one long stretch of desolation. Forest Hill and the plains thereabout, although suffering severely, have by no means had the inflictions thrust upon them that the above-named districts have. The absence of the Lockyer Creek in the Laidley and Forest Hill districts made all the difference, although Laidley Creek and Sandy Creek have by themselves done a great deal of damage. While Forest Hill plain presented one vast sheet of water, yet it is incomparable to the immense seas that ravaged the country from Gatton to Murphys Creek. From just beyond Gatton township to near Grantham there was but one vast sea, large landslips along the banks of the Lockyer and large banks of sand here and there showing the results of the accumulation and soakage of the waters. The '90 flood was eclipsed in places, while in others it was just the same in height. **Never in the memory of the older residents has such a flood taken place. From the Grantham railway station to within a mile of Gatton no idea can be formed of the tremendous body of water that accumulated from the overflow of the creek and rushed from the hillsides. At the present time the debris still hangs on the telegraph wires near Grantham, showing plainly that the waters exceeded in height the top of the wires, and therefore a body of water upwards of 30ft deep and miles in extent was the scene presented on Friday and Saturday last.** Paddocks on every side lie covered with sand and debris. Here the railway line suffered very much. For about 5 chains the permanent way was washed clean across into paddocks, and with great difficulty the line was replaced and ballast thrown in to permit of a train passing over on Tuesday. The effect of the rush of the waters at this place must be seen to allow any idea being formed of the damage done. Several of the Grantham

station paddocks have suffered severely. For about a mile from the railway station one paddock is almost covered with a deposit of sand. The fences have in places been swept clean away, while huge piles of logs and debris lie here and there. **Up the side of several of the ridges along the line lie heaps of logs and bushes, showing how high the water was, and touching land which has never previously been known to have been less than 15ft to 20ft of flood mark.** At Mr Scott's residence, Grantham, which is built on a hill near which no flood has ever been known to approach, the water on Friday almost reached the piles on which the house stands, the garden being nearly all covered. Along to Helidon painful evidences of the floodwaters are to be seen....**At the general store at Grantham the proprietor was compelled to sit on the roof all night while the seething waters rushed several feet round him, and the site of the proposed Grantham township was not to be seen for 24 hours. At Helidon, the Toowoomba Road bridge across the Lockyer is gone and two other bridges have also been swept away....Never have the waters been known to reach the limit they have on this occasion.** At Murphys Creek another record has been made. Here the road bridges have at instances been swept away, and others left standing in the midst of the areas while large bodies of water rush where the approaches once were. The fall of water from the ridges at Murphys Creek is described as terrific by the residents. Large gullies have been cut where none were before, and huge landslips are to be seen on every side. Here it is that the first railway block is to be met with. **The bridge over the Lockyer just beyond the station has been ruined. Two of the centre piers have been clean swept out of their beds, and the line hangs helplessly in the centre without support."**

12. The flooding was not confined to the Brisbane-Toowoomba region. *The Australian Town and Country Journal*, a newspaper published in Sydney, reported on 25 February 1893 that the wharves at Maryborough were six feet under water and parts of the town were flooded. All roads in the Burnett district were impassable and provisions were running short. On 16 February 1893 the river at Rockhampton was within 10 feet of “the great flood of 1887”. The Condamine River was three feet over the rails at Chinchilla. The newspaper said:

“The highest flood known was experienced in Toowoomba on February 17. The water was four feet deep in Russell Street and three feet deep in Ruthven Street. Several shops in Russell Street collapsed. The rush of water was fearful. There was no light in the town, as the gas works were flooded. Business was totally suspended all day. A man named John Cahill, while crossing Ruthven Street, was washed away and drowned, in the presence of hundreds of people.”

13. The same newspaper also reported that the water:

“... was quite four feet over Ruthven Street, falling with a tremendous noise eight feet over the embankment into Western Creek, making a cataract from the railway bridge to the Lake Hotel nearly 200 feet wide. Perth Street bridge over East Creek was washed away ...

Large landslips have occurred along the eastern side of the Range. Mr Apperman’s residence has gone down two chains, and is resting in a gully. A corner of Mr Brown’s verandah is hanging in mid-air. ...

At the height of the flood the water rose to the floor of the railway bridge, at the junction of East and West Creeks, 20 feet above its normal level. ...

The railways are literally paralysed. All along the flat country about Murphys Creek, Helidon, Laidley, Grantham and Grandchester the water is over the rails. At most of these places the embankments have given way.

At Goodna the starving people have been relieved by a boat load of provisions from Ipswich, taken by the Police Magistrate and others.

There is four feet of water in the main street at Laidley.

North Ipswich is almost totally submerged, only one half of the houses being visible.”

14. On 4 March 1893, *The Queenslander*, a Brisbane newspaper, reported:

“Yesterday week the Lockyer was rising with alarming rapidity, and continued to rise until about 3 pm, when it was within a couple of feet of the girders of the big railway bridge, and, after remaining nearly stationary for a few hours, it slowly subsided. ...

At Dinner Corner, Mr W Reynolds lost his barn, a quantity of harness, saddles and sundries, and his crop is also destroyed. At Helidon the damage done was chiefly confined to the bridges and large landslips. The new bridge over the Lockyer, at Helidon, was destroyed, and large slips have occurred at each side of where it stood. The bridge on the Flagstone Road is very badly damaged, and a large slip has also taken place at one end of it.

A portion of the permanent way was swept away near Ovena’s and near Dinner Corner.”

Grantham Floods Commission of Inquiry

THE TELEGRAPH, MONDAY EVENING, MARCH 20, 1931.

Thro' Flood Country. Horseback Journey. From Wide Bay District To the Darling Downs. Over Two Mountain Ranges. SWIMMING SWOLLEN RIVERS. Narrow Escapes—Extraordinary Experiences.

The following account of an adventurous ride on horseback from the Brisbane River Valley to Greenmount, on the Downs, during the late floods, gathered from a private letter received by Mr. A. H. Davis, from his father, should prove interesting, showing what difficulties a determined man and a good horse can overcome. Mr. Davis writes as follows: 'I started from Mambour station on January 28, intending to make my way home by Yabba, Mossdale, and Collington, but on my arrival at Mossdale it was raining heavily, and I found the creek was up. To have gone on that way I would have to cross the creek about 24 times. I found also that the Brisbane River was rising fast. On learning this rather discouraging news I made up my mind to retrace my steps and proceed on my way via Fowlow, Jimna, and Kilooy, and the Stanley River. Arriving at Fowlow, I found the creek here also very high, and it was raining in torrents. Luckily, having a good horse under me, I crossed in safety. The creek continued to rise, and the rain coming down with unabated severity had to stay here 10 days before I could make another start. Leaving Fowlow and the kind hospitality of Mr. Bolson, I entered again on my perilous journey through the Jimna goldfields, and here I found matters in a deplorable state, indeed. Everything was at a standstill, and some newly sunk shafts had caused in through continuous wet weather. The people were almost in a state of starvation—no tea or sugar, beef or flour on the ground. Actually they were living on bunya and oaten meal. Leaving this inhospitable region I proceeded and arrived at the foot of the range, about 10 miles from Jimna, that evening. Although it was raining heaven's hard, I was glad to say that I had very comfortable accommodation at the house of a farmer named Mr. Paton. Next morning it was still raining heavily, but I started for Kilooy, 15 miles away, and although I had a cross Sheepstation Creek, which was running strong and high, 13 or 14 times, my gallant horse landed me safely at the station about 3 p.m. I was in hope now that the greatest portion of my difficulties were at an end, but I assure you I found myself greatly mistaken. Being unable to cross the Stanley River, on the main road from Kilooy to Esk, I had to go round by Nicholson's sawmills, and here I saw what terrible destruction had been caused by the floods. The whole of the mill, timber, eight houses, and all belonging to them had been all washed away. Besides this fearful destruction of property I found, as I travelled along towards Mount Brisbane, six selectors completely washed away, outhouses, fences, crops, pigs, fowls, and all they had. After surmounting many difficulties, I arrived at Mount Brisbane, finding the creek a banker. The current was not very strong, so I put my horse to it, and the noble Kildare proved equal to the task, and landed me safely on the other side. Continuing my journey I arrived at Cross's Hotel, about 3 miles from the bridge crossing the Brisbane River, and stayed there for that night. Being unable to cross the Stanley River, on the main road from Kilooy to Esk, I had to go round by Nicholson's sawmills, and here I saw what terrible destruction had been caused by the floods. The whole of the mill, timber, eight houses, and all belonging to them had been all washed away. Besides this fearful destruction of property I found, as I travelled along towards Mount Brisbane, six selectors completely washed away, outhouses, fences, crops, pigs, fowls, and all they had. After surmounting many difficulties, I arrived at Mount Brisbane, finding the creek a banker. The current was not very strong, so I put my horse to it, and the noble Kildare proved equal to the task, and landed me safely on the other side. Continuing my journey I arrived at Cross's Hotel, about 3 miles from the bridge crossing the Brisbane River, and stayed there for that night. Being unable to cross the Stanley River, on the main road from Kilooy to Esk, I had to go round by Nicholson's sawmills, and here I saw what terrible destruction had been caused by the floods. The whole of the mill, timber, eight houses, and all belonging to them had been all washed away. Besides this fearful destruction of property I found, as I travelled along towards Mount Brisbane, six selectors completely washed away, outhouses, fences, crops, pigs, fowls, and all they had. After surmounting many difficulties, I arrived at Mount Brisbane, finding the creek a banker. The current was not very strong, so I put my horse to it, and the noble Kildare proved equal to the task, and landed me safely on the other side. Continuing my journey I arrived at Cross's Hotel, about 3 miles from the bridge crossing the Brisbane River, and stayed there for that night.

Lost and Found.

Lost and Found. Public Notices. Carriage. Public Notices.

Public Notices. Carriage. Public Notices. Carriage. Public Notices.

Carriage. Public Notices. Carriage. Public Notices. Carriage. Public Notices.

Public Notices. Carriage. Public Notices. Carriage. Public Notices. Carriage. Public Notices.

Public Notices. Carriage. Public Notices. Carriage. Public Notices. Carriage. Public Notices.

Public Notices. Carriage. Public Notices. Carriage. Public Notices. Carriage. Public Notices.

15. The flood of 1890, which was referred to in the report in the *Ipswich Advertiser*, had itself been the subject of a newspaper report in the *Darling Downs Gazette* of 12 March 1890. On that date the paper reported that a government official had managed to reach Toowoomba from Brisbane, travelling by rail as far as Gatton. Here too I have emphasised parts that I think are particularly important. The newspaper said:

“The whole country from Walloon to Gatton, a distance of 31 miles, may be succinctly described: it was under water. The floods were something terrible to see. All the low-lying lands were so inundated that their inhabitants had to remove long before. The Lockyer was in high flood and the bridge subjected to such a strain that Mr Stark [the government official] stopped the train at Gatton deeming it unsafe to cross. **Immense masses of debris had accumulated against the structure and every minute huge logs came down the swift current impinging against the mass with a force of a hundred battering rams, while the roaring of the stream could be heard for miles. ...**

Leaving Gatton, the line one and half mile this side was found washed away for 20 chains. **Grantham was found in places 10 feet under water**, and such was the state of the line and of the country that Mr Stark forwarded a recommendation to cancel all trains until further notice on account of the line being unsafe.”

16. There had been loss of life in Toowoomba and in Brisbane. Why was Grantham spared? The absence of any loss of life near Grantham is explained by the fact that it had not yet become an established township. Few people lived in Grantham itself at that time.

Chapter 4: The landscape and its history

The Lockyer Valley

1. In the upper Lockyer Valley, near the town of Murphys Creek, the Lockyer Creek is fed by its northern tributaries of Murphys Creek, Fifteen Mile Creek and Alice Creek. From there, the Lockyer Creek snakes down the valley heading generally east. Grantham sits near the bottom of the valley, more than 100 metres lower than the town of Murphys Creek.¹

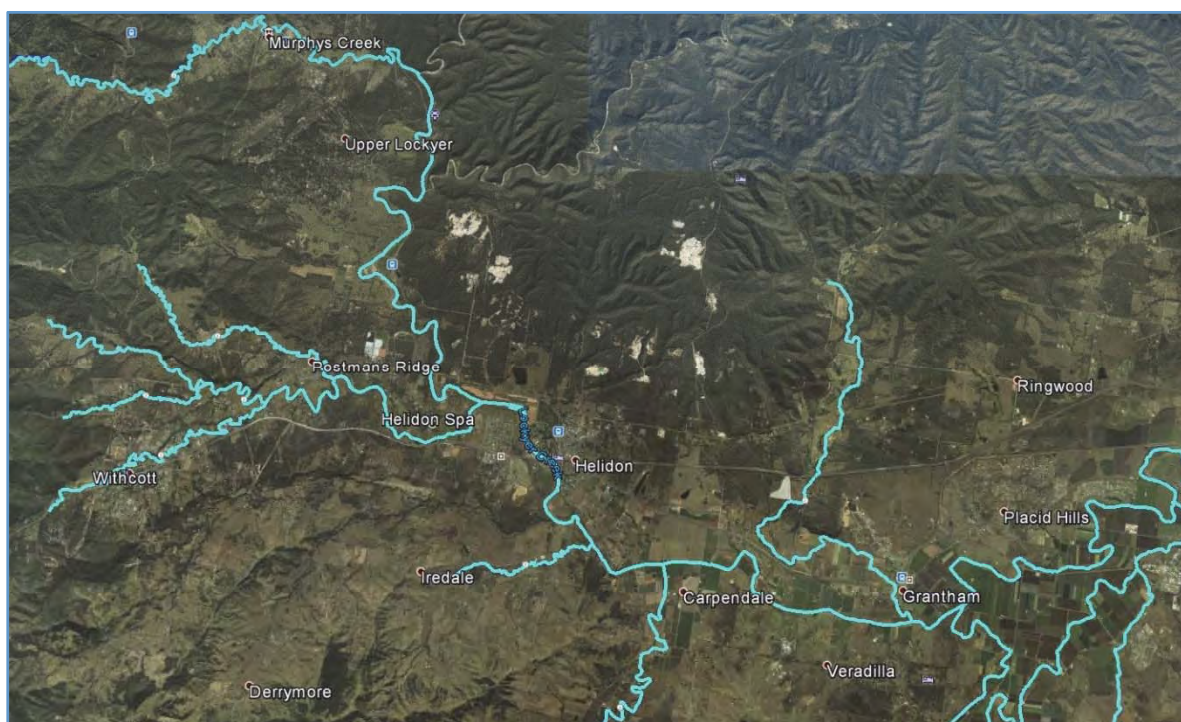

Figure 4.1: Map of the Lockyer Valley.

Source: Aerial imagery and watercourse information extracted from Queensland Globe (© State of Queensland 2015) and current as at 2013.

2. About three kilometres to the west of Grantham, the Lockyer Creek contorts itself to form a u-shaped bend. The Lockyer Creek cut that bend over a period of at least 10,000 years.² Since the early 1980s, the quarry pit for the Grantham sand plant has been excavated in the area within that bend.³ I return to the history of the Grantham sand plant below.
3. After it has completed the bend, the Lockyer Creek resumes its course to the east and glides past Grantham, which lies a few hundred metres to its north. As the Lockyer Creek passes Grantham, Sandy Creek feeds into it from the north. Sandy Creek bisects Grantham, as it travels south on the way to the Lockyer Creek.

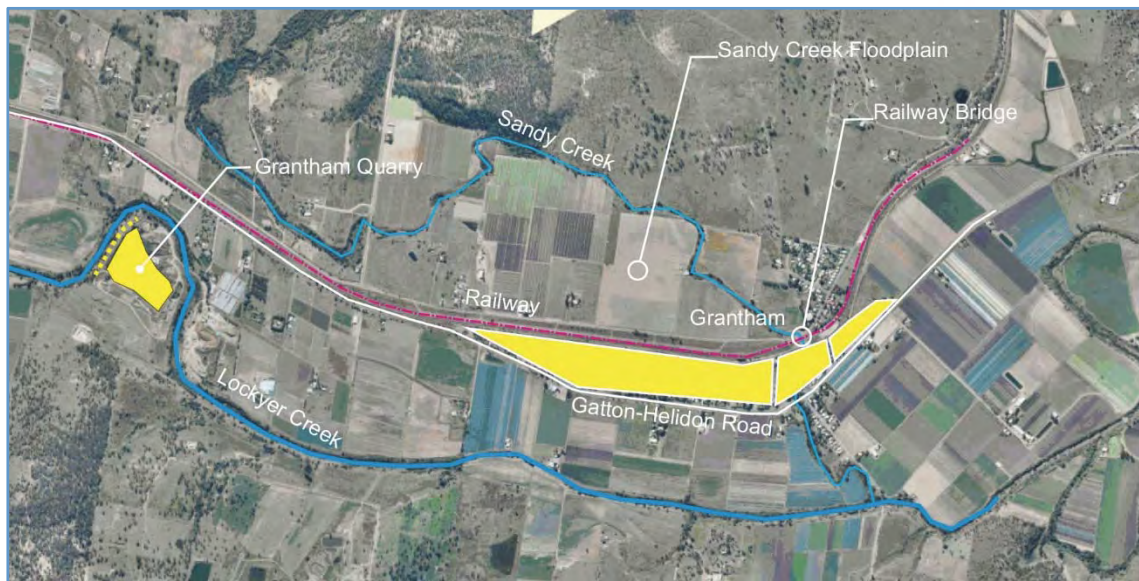

Figure 4.2: Image of the area between the Grantham Quarry and Grantham.

Source: Exhibit 144, Dr John Macintosh, *Expert Hydrology Report – 10 January 2011 Flood – Circumstances and Contributing Factors*, 11 August 2015 [p20: Figure 1.2].

4. The land between Helidon and Grantham slopes generally downwards from west to east, dropping about 15 metres⁴ over almost 10 kilometres. Between the quarry and Grantham there is a fall of about 10 metres over three kilometres.⁵ The main Toowoomba railway line runs past the Grantham quarry and through Grantham. In that area, the railway line has been built on an embankment that is up to two metres high.⁶

The Grantham sand plant

History of the sand plant

5. Beginning in about the mid-1940s, sand was extracted from the Lockyer Creek in the area where it makes the u-shaped bend near Grantham.⁷ Hence, the sand washing plant predates the quarry pit that now exists.
6. In January 1978, the Irrigation and Water Supply Commission⁸ advised the then-owner of the land, JG Martin & Son, that no more permits would be issued for the extraction of riverine quarry material from Lockyer Creek.⁹ JG Martin & Son continued to operate the sand washing plant by processing existing stockpiles before importing sand from its other quarries for processing.
7. In 1981, Gatton Shire Council granted town planning consent to Sullweis Pty Ltd for the sand extraction industry at the current site¹⁰ of the Grantham quarry, which was then agricultural land. Sullweis Pty Ltd had a close connection with JG Martin & Son although the exact relationship is not known.
8. In 1987, Sellars Holdings Ltd acquired the sand and gravel extraction operation and, in 1988, Sellars Holdings Ltd was acquired by CSR Readymix Ltd, although the sand plant continued to be operated under the Sellars Holdings Ltd name.
9. In 1990, Sellars Holdings Ltd was granted town planning consent by Gatton Shire Council to depart from the original approval in respect of certain conditions about the method of working the site and the extent of the site's restoration. The permitted changes were that less of the site would be excavated and worked than originally proposed and the

site would now only be partially rather than fully restored to create a body of water with batter slopes between the Lockyer Creek and the agricultural land to the south. A new office and weighbridge were also approved.¹¹

10. Town planning consent for the concrete batching plant was given by the Gatton Shire Council in 1991.¹²
11. Wagner Investments Pty Ltd acquired the land on which the sand and gravel business is located from CSR Readymix Ltd in November 1998 and Wagner Quarries Operations Pty Ltd commenced operating the business. This was one of a number of quarry and concrete operations owned by the Wagner companies (“Wagners”).¹³
12. In 2006, Wagners applied to Gatton Shire Council for a development permit for a material change of use to extend the existing approved activity to include the manufacturing of precast concrete elements.¹⁴ The Gatton Shire Council granted the development permit in 2007.¹⁵ However, it appears Wagners did not ultimately establish a precast concrete element business at the site.¹⁶
13. Boral Resources Qld Pty Ltd acquired the quarry from Wagners in November 2011 as part of a package of properties and equipment. The quarry was inspected by Boral Resources Qld Pty Ltd’s prior to its purchase and deemed to be exhausted of economically extractable sand resource for use in concrete.¹⁷ The quarry was not worked during Boral Resources Qld Pty Ltd’s ownership. ¹⁸ In June 2015, Boral Resources Qld Pty Ltd sold the Grantham quarry.
14. During the operation of the quarry, stockpiles of material had been placed inside the bend of the Lockyer Creek and around the quarry pit. On the western side of the quarry pit, between the pit and the Lockyer Creek, piles of material had been placed that formed what were described in the evidence as two bunds. There was an access track between the two bunds. The location of the bunds is marked by the dotted yellow line in Figure 4.2.
15. For many decades, the Grantham sand plant was a feature of the area, providing employment opportunities for people in the area and, no doubt, making an economic contribution to the Lockyer Valley.

Terms of Reference and the eastern bund

16. A matter of particular concern for some members of the Grantham community in the lead up to this Commission was whether the Grantham quarry had an effect on the flooding of Grantham. My Terms of Reference reflect this concern. Three of the five matters in respect of which I am required to make a full and careful inquiry expressly direct me to consider the possibility that the existence of the quarry caused or contributed to the flooding or the consequences of the flooding.
17. One of the reasons underlying the community concern was the belief of at least some members of the community that the working of the quarry had, over time, made a significant alteration to the natural landscape, and therefore the natural flow of water in a flood. In particular, some members of the community believed that material, which was of a significant height and of a significant length, had been built up on the western embankment after Wagners acquired the quarry in 1998. That would mean it was built up at a time after the 1996 flood, which had been the last big flood before 2011.
18. In addition, my first Term of Reference requires me to consider the contribution of natural or man-made features of the landscape to the flooding of Grantham. Necessarily, I must determine whether a relevant feature is natural or man-made and, to do so, I must consider the history of the feature to discern how it came to be.
19. Finally, my fifth Term of Reference requires me to consider how, among other things, the effect of the quarry on the flooding was first investigated. Part of the relevant context to the issues about the initial investigations is the community concerns that a bund had been built up to a significant height in recent years before the floods.

20. Unsurprisingly, given what I have said about my Terms of Reference, I heard a significant amount of evidence, both lay and expert, about whether and when the bunds on the western embankment were constructed. Indeed, in his opening address to the Commission, Wagners' counsel expressly submitted that one of the matters of controversy that I would need to determine was whether Wagners had added any material to the western side of the quarry. However, in its closing submissions, Wagners conceded the bunds on the western embankment were man-made but submitted I should not address when they were constructed.¹⁹ There were three reasons advanced in support of that submission.
21. The first reason was that it did not fall within the ambit of my Terms of Reference to consider when the bunds were constructed. For the reasons I have already outlined, this is not correct.
22. The second reason was that as Wagners now conceded the bunds were man-made, it was not necessary for me to consider how they came to be built. That is not correct. I have been commissioned to make full and careful inquiry into all of the matters identified in my Terms of Reference. I cannot proceed on the basis of an assumed fact because one or all of the parties given leave to appear accept, or encourage me to accept, that a particular matter is true. I must satisfy myself about that matter if it is relevant to my Terms of Reference. This proceeding is not a trial in which parties are at liberty to define the issues. The origin of the embankments has been a matter of serious community concern. It must be examined and the facts published.
23. The third reason was that Wagners had been subjected to many untruthful allegations by certain sections of the media and therefore I ought not consider whether Wagners added material to the bunds because it may encourage those same segments of the media to continue an untruthful campaign against Wagners. The spread of misinformation about the effect of the quarry on the flooding has been, and is, a matter of grave concern to me. One of the reasons it is important to understand the truth about the cause of the flooding is because planning in the Lockyer Valley, both for evacuation and development, must be undertaken on the basis of the truth about why the flooding occurred. However, the possibility that others may misrepresent my findings is not a reason to forgo an investigation in accordance with my Terms of Reference. Nevertheless, I emphasise the fact that I have made findings about the building up of the bunds should not encourage anyone to advance the theory that the quarry caused or materially contributed to the flooding of Grantham. To do so, having regard to the other findings I have made, could only have the consequence of mischievously spreading misinformation.

History of the bunds

24. Mr David Starr, the geotechnical engineer engaged by the Commission, provided a report detailing his assessment of the changes to the natural ground where the quarry is now located.
25. Prior to development of the quarry, the area within the bend was a gently sloping alluvial floodplain, bounded on three sides by the Lockyer Creek. During the operation of the quarry pit, stockpiles of material had been placed inside the bend of the Lockyer Creek and around the quarry pit. On the western side of the quarry pit, between the pit and the Lockyer Creek, piles of material had been placed that formed what were described in the evidence as two "bunds".
26. The location of the two bunds on the western side of the pit, referred to as the western bund and the eastern bund, as they were before they were overtopped by the floodwaters and washed away, are identified in Figure 4.3.



Figure 4.3: Image showing location of pre-flood bunds and the location of the main breach
 Source: Exhibit 144, Dr John Macintosh, *Expert Hydrology Report – 10 January 2011 Flood – Circumstances and Contributing Factors*, 11 August 2015 [p70: Figure 8.15] (amended).

27. The bunds on the western side of the quarry pit were each above natural ground level. Mr Starr’s examination of the bunds, including the digging of test pits, led him to the conclusion the eastern bund was generally three to four metres in height above the natural ground level, though it varied between two and six metres and dipped to close to natural ground level in two locations. The western bund was about two metres above natural ground level and ran only half of the length of the eastern bund.²⁰ However, the bunds were not, in Mr Starr’s opinion, engineered structures. Rather, they appear to have been made by the successive dumping of loads of fill, for example from a truck or a front-end loader.²¹
28. Mr Starr prepared a schematic of a cross-section at an illustrative point along the area between the Lockyer Creek and the western side of the quarry pit. That schematic is reproduced as Figure 4.4. The schematic shows heights in terms of metres Australian Height Datum (AHD).

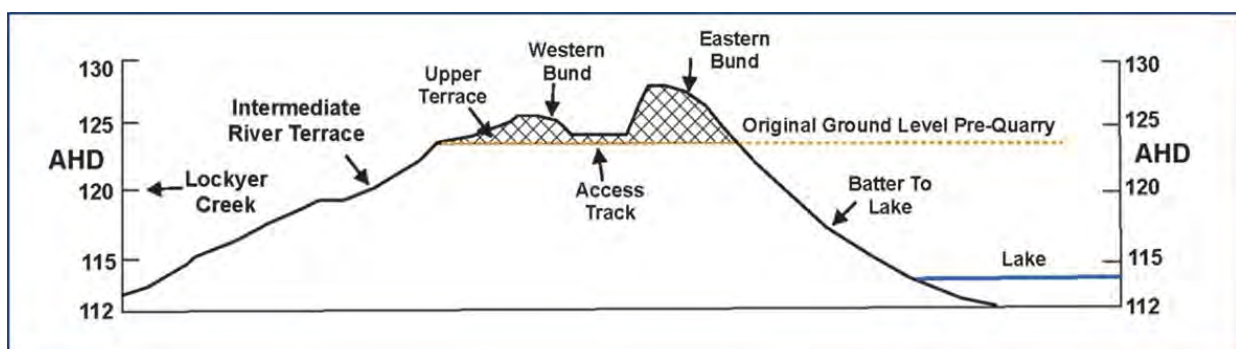

Figure 4.4: Schematic cross-section through area between the Lockyer Creek and the western side of the quarry pit
 Source: Exhibit 131, Mr David Starr, *Grantham Quarry – Geotechnical Investigations & Expert Opinion on Formation of Earthworks*, 28 July 2015 [p1: Plate 1].

29. Although there was no evidence from anybody directly engaged in building-up the bunds, I am satisfied the bunds were not placed in this position for the purpose of flood mitigation.

30. There are two reasons why I have come to that conclusion. First, because the height of the eastern bund varied significantly and was lowest in the area where the natural ground was lowest. That was, and would obviously have been, the first place to be overtopped if the Lockyer Creek rose substantially. It would make no sense to build the bunds for flood mitigation but not build up the lowest area. Secondly, there was an access track that ran down into the quarry pit between the southern end of the bund and a southern stockpile. Again, it would make no sense to have such an access track if the intention was to prevent the quarry pit flooding from the west when the Lockyer Creek rose.
31. No party given leave to appear any longer challenges the conclusion that the two bunds were each above natural ground level and therefore, necessarily, man-made²², nor submits that the bunds were built for the purposes of flood mitigation.²³
32. To determine when the bunds had come to be built, Mr Starr undertook an analysis of various photographs taken over time and examined stereographic pairs of photographs, taken at various times since 1982, under a stereograph to determine changes in heights of material along the area between the western edge of the quarry pit and the Lockyer Creek. The nature of his analysis is considered in detail in Appendix A: Expert reports - geotechnical investigations.
33. Based on this analysis, Mr Starr's opinion is that the construction of the bunds commenced after August 1997 and before June 2001, although it was possible that some additional stereo photographs from 1997 showed the level of the land to the east and west of the track being up to half a metre higher than the track itself. By June 2001, construction of the eastern bund had commenced but it was not as high as it was by the time of the floods in January 2011. It is possible the eastern bund had reached its full height in its pre-flood form by 2005, but this is not certain as there are no stereoscopic photos available for this time. However, it had certainly reached its full height by 2008 and this is confirmed by a 2008 survey which shows the bunds as being essentially in the same location and of the same height as they were by the time the August 2010 LiDAR survey was undertaken. There was also a change between 2001 and 2009 at the northern end of the bunds where the access track was changed and cut through the area of the western bund. This meant that by 2009 the northern end of the eastern bund was in a location where the western bund has been in 2001.²⁴
34. Mr Starr's opinion is consistent with the evidence of eyewitnesses.
35. There is no documentary evidence about the construction of the bunds. The Lockyer Valley Regional Council, which has a complaints-driven system for monitoring compliance with development approvals, has no record of any complaint being made about the bunds.²⁵ Due to the passage of time, information from owners prior to Wagners is also very limited. Martins, which operated the sand plant in the 1970s and 1980s, has ceased to exist and its records cannot be located. Sellars Holdings Ltd, which operated the quarry from 1988 to 1998 (the last year when owned by CSR Readymix Ltd) has also ceased to exist as an entity, and Holcim Pty Ltd, which inherited CSR Readymix Ltd's records, is unable to provide any advice about the operations²⁶.
36. However, eyewitnesses generally agreed that from the 1960s through to the early 1990s, the bunds were not present. Mr John Mahon recalls fishing in the adjacent creek as a child in 1964-1968, at which time the bunds did not exist and the site was flat.²⁷ Mr Tom Friend recalls that in the late 1970s and 1980s, the area where the quarry is now located was just a flat paddock, growing rock melons and grain.²⁸ Mr Kenley Arndt, who went fishing in the creek 30 years ago, also described it as "flat like a table",²⁹ and Mr Tony McIntosh, who as a teenager made pocket money picking crops on the farm that then occupied the site, described the creek terraces and the gradual slope on the land.³⁰
37. The evidence of those who worked at the site, including employees of Wagners, was also consistent with bunds, and in particular the eastern bund, having been substantially altered and increased in height after Wagners acquired the sand plant.

38. Mr John Johnson, who regularly visited the quarry as Sellars Holdings Ltd's Manager for Quarry Operations in 1987 and 1988, stated there were stockpiles of overburden dumped untidily, in an area "located to the west of the lucerne patch from a point about halfway up the bend of the Lockyer Creek heading north up to an area about level with the top of the two pits that were being dug". During examination, Mr Johnson agreed the piles he remembered appeared similar to the western bund that is visible in the 2001 aerial photograph³¹. However, his description of the location corresponds to the location of some stockpiles in the south-western corner of the site, identified by Mr Starr in the 1995 aerial photographs, which at some time before 1997 were compacted and levelled to form an access track, and did not form part of the eventual eastern or western bunds.
39. Mr Bob Stephenson worked at the sand plant from 1990 to 1998 when it was owned by CSR Readymix Ltd. He does not recall having deposited overburden around the quarry pit and testified there were no bunds around the pit at all during this time.³² This is consistent with the evidence of Mr Martin Warburton, who visited the sand plant in 1993, and described walking across the causeway and being able to look across the quarry flats and see the creek bank on the other side.³³ It is also supported by evidence from Mr John Gallagher who worked on the farm next to the quarry until 1996 and has continued to walk his dogs there until the present day. He testified there was nothing like the bunds in the area between the western side of the quarry pit and the Lockyer Creek prior to 1998.³⁴
40. Mr Dean Heit worked at the Grantham sand plant from 1998 to 2002. He recalled a bund two to three metres high in place on the western side of the quarry when he started work there in 1998,³⁵ but it was not where the eastern or western bunds are now located. Rather, it was on the edge between the upper and lower benches within the quarry pit itself.³⁶ The area of the upper bench was ultimately consumed as the excavation of the quarry pit continued. Mr Trevor Leishman, who worked at the quarry in 2001, went onto the embankment once or twice, where he saw a bund that was "not very high".³⁷
41. Mr John Stark was employed by Wagners as the General Manager for Quarries between 2002 and 2004. He recalled a safety bund on the western side of the Grantham quarry that was already there when he started in 2002.³⁸ He recalls it being at least one metre high but not so high that it was well over his head as he was walking along the access track.³⁹ It was certainly not three to four metres high and had it been, he would have noticed.⁴⁰
42. That evidence is consistent with construction of the eastern bund having commenced by 2001 but not yet being at its full height.
43. Only one witness reported having seen a bund on the embankment before the late 1990s. Mr McIntosh testified that in the 1970s and 1980s, an embankment was built between the quarry and the fence line (which is located on the creek bank terrace) along a 400 to 500 metre section of the creek. He testified the material "was compacted by machinery when laid down, and used as a track by trucks."⁴¹
44. No witness gave evidence that they saw the western and eastern bunds already in place and at their full height at the time that Wagners acquired the Grantham sand plant in 1998.
45. Several witnesses, however, reported they first observed the eastern bund in the late 1990s or early 2000s. Mr Friend described bunds being formed on the western and northern banks of the area of the quarry between 1996 and 2004 by pushing up dirt and rock.⁴² Mr Gallagher noticed changes from 2000 on, with material being placed on the western embankment in jagged heights, though in his statement he said it began in the late 1990s.⁴³ Mr McIntosh recalled that between 2000 and 2010, material was piled along the length of the western side of the quarry, creating a wall about five metres high.⁴⁴
46. A number of witnesses reported noticing the bunds at a substantial height from 2005 onwards. Mr Arndt testified he could see the bund from his fishing spot along the Lockyer Creek from 2005, and thought it could have been there earlier, but "little and low."⁴⁵

47. Jonathon and Annaka Sippel moved into their house, close to the quarry, in 2006. Sometime after this, Mr Sippel visited the site to repair a water pump and saw the eastern bund two and a half times higher than his utility. Giving evidence, he could not recall seeing the smaller western bund, but he mentions it in his statement.⁴⁶ Ms Sippel also saw the bund before 2008.⁴⁷
48. Mr Gallagher recalled that by 2005, the bund on the western side of the quarry was “massive”, while the dumps of material on the northern side of the quarry grew into a wall of uneven height.⁴⁸
49. Wagners employee, Mr Nicholas Duff, worked at the sand plant from 2007 to 2013 and recalled there was a bund that ran along the edge of the pit about three metres high, and a smaller bund along the creek about one and a half to two metres high, both of which were already there when he started.⁴⁹ Mr Athol Fowler worked at the sand plant from 2007, and Mr Cameron Coleman and Mr Phillip Gregory both started work with Wagners in management positions that involved visiting the sand plant regularly from 2010; all three saw the bund on the western side of the quarry pit.⁵⁰
50. None of the employees at Wagners who gave evidence reported ever seeing material being placed on the western embankment, and none reported placing material there themselves⁵¹.
51. Those witnesses who have or had management positions in relation to the Grantham sand plant (Mr Heit, Mr Fowler, Mr Gregory, Mr Coleman, Mr Stark, and Mr Denis Wagner) each stated, in effect, that to the best of their knowledge and belief, no material was added to or taken away from the western embankment.⁵² However, the managers rarely went over to the western embankment, concentrating their time and attention on the batching plant area and the quarry pit. Mr Heit was site manager from 1998 to 2002 but drove around on the access track “not even half a dozen times”;⁵³ Mr Stark was General Manager in 2002 to 2004 and visited the sand plant once a fortnight but does not remember ever driving along the access track;⁵⁴ Mr Fowler who was the manager of the sand plant in 2010 very rarely went out along the access track;⁵⁵ and Mr Wagner, while he was Manager of Quarries from 1998 until 2001, visited the sand plant weekly, but cannot recall walking around the pit.⁵⁶
52. Several reasons have been offered as to why it was probable that no material was placed there. First, as stated by several Wagners employees, Wagners policy was not to work under power lines. Mr Wagner testified that Wagners would not have placed fill on the western embankment due to the power line;⁵⁷ and Mr Gregory stated that work would not be done under power lines for safety reasons.⁵⁸ Mr Duff and Mr Fowler both stated that no stockpiles would be placed there in order to keep access to the poles for the power company.⁵⁹ Mr Wagner also gave evidence that the method of operation of the plant was to place waste material on the southern side of the quarry.⁶⁰
53. At an operational level, Mr Wagner said the site manager would generally be responsible for a decision to increase the height of a bund, or to start dumping material in a new location. The site manager would also be expected to raise any potential issues about proposed activities with the senior management of Wagners.⁶¹ However, the site manager would not ordinarily be aware of the development approval conditions,⁶² so a site manager considering dumping on the western embankment may not have known there were issues to raise in this regard, though they should, in any case, have raised the issue of the power line. It appears possible, if unlikely, that at some point in time, a site manager approved dumping of overburden on the western embankment without drawing it to the attention of senior managers. Another possibility is that they did raise it with their senior manager, and the work was agreed to proceed with the bunds placed to either side of the power line to maintain safety, but that no record was made of this conversation.
54. While the site manager would give instructions to staff on a day to day basis on the tasks to be done that day, it would not have been thought necessary to issue instructions to stop doing something that may have been an existing practice.⁶³ It is therefore also possible that operational staff may have continued to dispose of material in a location they found convenient, without it coming to the attention of the site manager.

55. Therefore, it is entirely feasible that over some period between 1998 and 2010, an employee or employees of Wagners was dumping material on the western embankment, despite the existence of the policies mentioned above. Indeed, given the weight of evidence that, at the very least, the height of the eastern bund altered and increased substantially during the time that Wagners owned and operated the quarry, some employee or employees of Wagners must have done so. I accept this must have been done without the knowledge of Wagners senior management.
56. Based on the evidence of the eyewitnesses, together with the expert opinion, I consider the two narrow bunds lying either side of the access track on the western embankment, as well as the stockpiles on the north-western, north-eastern and southern sides of the quarry pit, are man-made features. The bunds were not engineered structures, and were probably made by the successive dumping of loads of fill, for example from a truck or a front-end loader.
57. I have concluded that construction of the bunds in the location in which they were evident by 2011 had commenced by 2001. The bunds increased in height over the following years and likely reached their final height between 2005 and 2008, remaining largely unchanged until the 2011 flood event.

The conditions of approval

58. Evidence was put before the Commission as to the conditions of the development approvals granted with respect to the Grantham quarry. Ultimately, all parties given leave to appear agreed it was beyond my Terms of Reference to make findings as to whether there were breaches of the conditions of approval. I agree. My Terms of Reference do not expressly permit consideration of whether there was any breach of the conditions of approval and, unlike the question of whether the bunds were natural or man-made and how they came to be physically in place, it is not necessary for me to consider whether there was a breach of the conditions to fully and carefully investigate the matters in respect of which I am specifically directed to inquire.
59. It was submitted by one party that I ought to consider making comments about a regulatory system that would allow the unregulated building of structures which have the capacity to act as levee banks and make recommendations about changes to that system.⁶⁴ However, it would not be appropriate for me to do so. There are two reasons why that is so.
60. First, my Terms of Reference do not embrace inquiring into the adequacy of the regulation of levee banks and, consequently, I have not heard evidence about the competing considerations that would underlie, and be relevant to, the form of regulation as it existed in 2011 and as it exists now. I am also persuaded by the submission on behalf of the Lockyer Valley Regional Council that I do not have enough information available to comment on the adequacy of the system.⁶⁵
61. Second, the adequacy of the regulation of levees is a matter that was within the Terms of Reference of the Queensland Floods Commission of Inquiry. It made recommendations. The State Government has implemented legislative changes in response to those recommendations. The system that now applies to the regulation of the construction of levees is substantially different from the system that existed at or before January 2011. It is, for example, far more prescriptive. That highlights why it would not be appropriate for me to embark on commentary about the adequacy of the regulatory system. The system has changed. It has changed in response to the recommendations of a Commission specifically tasked with considering the adequacy of the system. I have no evidence before me that would put me in a position to consider the adequacy of the system and the bunds with which I am concerned were built before the new system came into effect.

- ¹ Survey Control Mark Report: Mark Number 66540; cf. Survey Control Mark Report: Mark Number 190245; Data obtained from Queensland Globe (© State of Queensland 2015).
- ² Transcript 6 August 2015: David Starr [p1002: lines 33-45].
- ³ Exhibit 51, Conditions of approval to sandmining operation dated 20 October 1981, 29 July 2015.
- ⁴ Survey Control Mark Report: Mark Number 57164; cf. Survey Control Mark Report: Mark Number 190245; Data obtained from Queensland Globe (© State of Queensland 2015).
- ⁵ Exhibit 255, Affidavit of Peter Todd, 30 July 2015 [p6: para 24(c)].
- ⁶ Exhibit 144, Dr John Macintosh, Expert Hydrology Report – 10 January 2011 Flood – Circumstances and Contributing Factors, 11 August 2015 [p31: para 52].
- ⁷ Exhibit 214, Affidavit of Stephen Johnston, 17 July 2015 [Exhibit 1, p2: para 13 - p3: para 14].
- ⁸ The Irrigation and Water Supply Commission was the predecessor to the Queensland Water Resources Commission.
- ⁹ Exhibit 214, Affidavit of Stephen Johnston, 17 July 2015 [Exhibit 1, p3: para 15].
- ¹⁰ Exhibit 51, Gatton Shire Council Town Planning Consent – Conditions of Approval for Sand Mining Operation, 20 October 1981.
- ¹¹ Exhibit 52, Application for Town Planning Consent by Sellars Holdings Ltd, off Warrego Highway, Grantham, 6 November 1989.
- ¹² Exhibit 300, Gatton Shire Council Town Planning Consent – development of a concrete batching plant (decision 13 March 1991), item 5, documents provided by Wagners on 5 June 2015.
- ¹³ Exhibit 50, Statutory declaration of Denis Wagner, 11 June 2015 [p1: para 7 - p2: para 10].
- ¹⁴ Submission on behalf of Wagner Investments Pty Ltd and Wagners Australian Operations Pty Ltd, 3 July 2015 [p16: para 52].
- ¹⁵ Submission on behalf of Wagner Investments Pty Ltd and Wagners Australian Operations Pty Ltd, 3 July 2015 [p16: para 53].
- ¹⁶ Submission on behalf of Wagner Investments Pty Ltd and Wagners Australian Operations Pty Ltd, 3 July 2015 [p16: para 53].
- ¹⁷ Exhibit 299, Statutory Declaration of Simon Jeffrey, 12 June 2015, Grantham Sand Quarry Site Inspector report, 25 June 2013 [Annexure A].
- ¹⁸ Exhibit 299, Statutory Declaration of Simon Jeffrey, 12 June 2015, Grantham Sand Quarry Site Inspector report, 25 June 2013 [Annexure D].
- ¹⁹ Transcript 14 September 2015 [p1491: line 24 - p1493: line 10].
- ²⁰ Exhibit 131, Mr David Starr, *Grantham quarry – geotechnical investigations and expert opinion on formation of earthworks*, 28 July 2015 [Section 10]; Transcript 6 August 2015: David Starr [p1033: lines 30–44].
- ²¹ Transcript 6 August 2015: David Starr [p1037: line 37 - p1038: line 6].
- ²² Written submissions made on behalf of Wagner Investments Pty Ltd and Wagners Australian Operations Pty Ltd, 14 September 2015; Written submissions made on behalf of Lockyer Valley Regional Council, 10 September 2015; Written submissions made on behalf of West Grantham residents, 2 September 2015; Written submissions made on behalf of Grantham families, 2 September 2015; Written submissions made on behalf of the State of Queensland, 28 August 2015; Written submissions made on behalf of Queensland Rail, 28 August 2015.
- ²³ Transcript 14 September 2015: Mr Tobin [p1435 lines 4 – 9], Mr Holt [p1457 lines 26 – 33]; Written submissions made on behalf of Wagner Investments Pty Ltd and Wagners Australian Operations Pty Ltd, 14 September 2015; Written submissions made on behalf of Lockyer Valley Regional Council, 10 September 2015; Written submissions made on behalf of West Grantham residents, 2 September 2015; Written submissions made on behalf of Grantham families, 2 September 2015; Written submissions made on behalf of the State of Queensland, 28 August 2015; Written submissions made on behalf of Queensland Rail, 28 August 2015.
- ²⁴ Transcript 6 August 2015: David Starr [p1010: line 45 – p1011: line 34].
- ²⁵ Exhibit 45, Statement of John Gallagher, 20 May 2015 [p3: para 9]; Exhibit 94, Statement of Ian Flint, 11 June 2015 [paras 7-9]; Transcript 5 August 2015: Ian Flint [p911: lines 32-45].
- ²⁶ Statement of Mark Campbell, 15 July 2015 [paras 5, 9 and 10].
- ²⁷ Exhibit 224, Statement of John Mahon, 7 July 2015 [p1: paras 5-6].
- ²⁸ Exhibit 47, Statement of Tom Friend, 1 July 2015 [p1: para 3].
- ²⁹ Exhibit 34, Statement of Kenley Arndt, 1 July 2015 [p1: para 3].
- ³⁰ Exhibit 48, Statement of Anthony McIntosh, 27 May 2015 [p2: para 6-8].
- ³¹ Transcript 30 July 2015: John Johnson [p679: line 5 - p683: line 15].
- ³² Transcript 3 August 2015: Bob Stephenson [p704: line 44 - p705: line 2].
- ³³ Transcript 24 July 2015: Martin Warburton [p416: line 28 - p418: line 20].
- ³⁴ Transcript 28 July 2015: John Gallagher [p461: line 10 - p465: line 15; p466: line 38 - p470: line 44].
- ³⁵ Exhibit 64, Statement of Dean Heit [para 14].
- ³⁶ Transcript 30 July 2015: Dean Heit [p688: line 30 – p690: line 13].
- ³⁷ Transcript 4 August 2015: Trevor Leishman [p744: line 10 – p746 line 3].
- ³⁸ Exhibit 65, Statement of John Stark [para 13].
- ³⁹ Transcript 30 July 2015: John Stark [p695: line 21 – p696: line 5].
- ⁴⁰ Transcript 30 July 2015: John Stark [p696: line 44 – p697: line 7].
- ⁴¹ Exhibit 48, Statement of Anthony McIntosh, 1 July 2015 [paras 11– 12].
- ⁴² Transcript 28 July 2015: Tom Friend [p503: lines 24-34]; Exhibit 47, Statement of Tom Friend, 1 July 2015 [paras 5-7].
- ⁴³ Transcript 28 July 2015: John Gallagher [p462: line 10 – p464: line 6]; Exhibit 45, Statement of John Gallagher, 1 July 2015 [para 7].
- ⁴⁴ Exhibit 48, Statement of Anthony McIntosh, 1 July 2015 [para 13].
- ⁴⁵ Transcript 23 July 2015: Kenley Arndt [p337: lines 6-19].
- ⁴⁶ Transcript 21 July 2015: Jonathon Sippel [p113: line 6 - p116: line 9]; Exhibit 25, Statement of Jonathon Sippel, 1 July 2015 [paras 8-9].
- ⁴⁷ Exhibit 246, Statement of Annaka Sippel, 1 July 2015 [paras 43–51].

⁴⁸ Transcript 28 July 2015: John Gallagher [p463: line 3 – p465: line 35].

⁴⁹ Exhibit 98, Statement of Nicholas Duff, 30 June 2015 [paras 11-12].

⁵⁰ Exhibit 97, Statement of Cameron Colman [para 15]; Exhibit 59, Statement of Athol Fowler, 1 July 2015 [para 18]; Exhibit 99, Statement of Phillip Gregory, 1 July 2015 [para 30].

⁵¹ Exhibit 64, Statement of Dean Heit [para 14]; Transcript 30 July 2015: Dean Heit [p688: line 30 – p690: line 13]; Transcript 4 August 2015: Trevor Leishman [p744: line 10 – p746: line 3]; Exhibit 65, Statement of John Stark [para 13]; Transcript 30 July 2015: John Stark [p695: line 21 – p696: line 5]; Transcript 30 July 2015: John Stark [p696: line 44 – p697: line 7]; Exhibit 98, Statement of Nicholas Duff, 30 June 2015 [paras 11-12]; Exhibit 97, Statement of Cameron Colman [para 15]; Exhibit 59, Statement of Athol Fowler, 1 July 2015 [para 18]; Exhibit 99, Statement of Phillip Gregory, 1 July 2015 [para 30].

⁵² Exhibit 50, Statement of Denis Wagner, 11 June 2015 [para 18]; Exhibit 59, Statement of Athol Fowler, 1 July 2015 [para 15]; Exhibit 65, Statement of John Stark, 1 July 2015 [para 12]; Exhibit 97, Statement of Cameron Coleman, 2015 [para 14]; Exhibit 99, Statement of Phillip Gregory, 1 July 2015 [para 12]; Transcript 29 July 2015: Denis Wagner [p555: line1 - p557: line 35]; Transcript 30 July 2015: Athol Fowler [p668: line 27 – p669: line 28]; John Stark [p696: lines 26-28].

⁵³ Transcript 30 July 2015: Dean Heit [p690: lines 9–13].

⁵⁴ Transcript 30 July 2015: John Stark [p696: line 14].

⁵⁵ Transcript 30 July 2015: Athol Fowler [p668: lines 33–34].

⁵⁶ Transcript 29 July 2015: Denis Wagner [p554: lines 11–17].

⁵⁷ Transcript 29 July 2015: Denis Wagner [p557: lines 18-28].

⁵⁸ Exhibit 99, Statement of Phillip Gregory, 1 July 2015 [para 12].

⁵⁹ Exhibit 98, Statement of Nicholas Duff, 30 June 2015 [para 10]; Exhibit 59, Statement of Athol Fowler, 1 July 2015 [para 17].

⁶⁰ Transcript 29 July 2015: Denis Wagner [p557: lines 13–16].

⁶¹ Transcript 29 July 2015: Denis Wagner [p577: lines 30–39].

⁶² Transcript 29 July 2015: Denis Wagner [p579: lines 8–12, p581: line 13].

⁶³ Transcript 29 July 2015: Denis Wagner [p621: lines 40-45].

⁶⁴ Transcript 14 September 2015 [p1460: line 18 – p1461: line 13].

⁶⁵ Transcript 14 September 2015 [p1482: line 22 – p1483: line 44].

Chapter 5: What caused the Grantham flood

The rain on 10 January 2011

1. The heavy rainfall throughout December 2010 and in the first week of January 2011 saturated the catchments in the Lockyer Valley.¹ If more rain were to fall, none of it could be absorbed into the ground.
2. On the morning of 10 January 2011, two storm cells developed to the east of the Lockyer Valley. The Bureau of Meteorology identified the cells and their movement on images from the Mt Stapylton Radar, depicted in Figure 5.1.

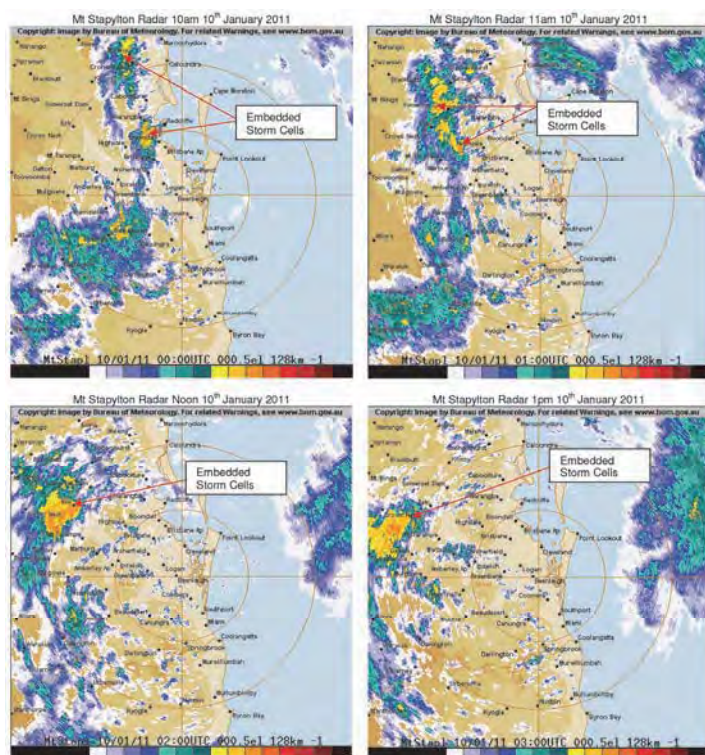

Figure 5.1: Mt Stapylton radar imagery from 10 am to 1 pm on 10 January 2011

Source: Exhibit 1, Bureau of Meteorology, *Southeast Queensland Floods – January 2011* [p5: Figure 2.2.1].

3. The storm cells travelled west from the coast and merged over Esk after 11 am. The merged storm cell was now slower but more intense. It continued to the south west and by about 1 pm arrived over the upper Lockyer Creek catchment. There was intense rainfall into the catchments of Fifteen Mile Creek, Alice Creek and then Murphys Creek, the three northern tributaries of Lockyer Creek, and also into the catchment for the Lockyer Creek itself. “The shape of the weather system uniquely matched the ‘bowl’ shape at the top of the Lockyer catchment” which had the consequence that “the high intensity rainfall [fell] wholly within the upper catchment and [was not] distributed to adjacent creek systems.”²
4. Over two hours, 90 millimetres (approximately 3.5 inches) of rain fell.³

5. This intense rainfall fell directly into the saturated catchment and produced a torrent of water that surged down the Lockyer Creek catching the people of the Lockyer Valley by surprise. It caused death and devastation as it passed through Murphys Creek, Postmans Ridge and Helidon.
6. The extremity of the surge down the Lockyer Creek was recorded at the gauging station at Helidon. This is the first major gauge along the course of the Lockyer Creek that records the water level of the Lockyer Creek.⁴ As at 10 January 2011, the relevant gauging station was gauge no. 143203C, also known as Helidon gauge no. 3.⁵ Helidon gauge no. 3 had been in operation since 1987.⁶
7. Helidon gauge no. 1 was in operation from 1926 to 1971. The maximum water level ever recorded by Helidon gauge no. 1 was 4.740 metres on 8 November 1926. Helidon gauge no. 2 was in operation from 1965 to 1989. The maximum water level recorded by Helidon gauge no. 2 was 7.550 metres on 27 January 1974.⁷ That was the highest water level ever recorded at Helidon until 10 January 2011.
8. On 10 January 2011, the Lockyer Creek rose so high that it overtopped the gauging station. Because it was overtopped, the gauge stopped recording at 12.66 metres but resumed recording once the water level dropped.⁸ The peak flood height was subsequently surveyed at 13.88 metres at the gauging station.⁹ That water level of the Lockyer Creek is far greater than had been recorded before or since at Helidon.
9. Dr David Newton, an expert hydraulic engineer who provided two reports tendered to this Commission, prepared a graph and table comparing significant recorded water levels at Helidon. As the level for the 1974 flood was recorded at Helidon gauge no. 2, rather than Helidon gauge no. 3, Dr Newton included adjusted data for the 1974 flood so as to approximate the likely level if Helidon gauge no. 3 had been in operation in 1974.¹⁰

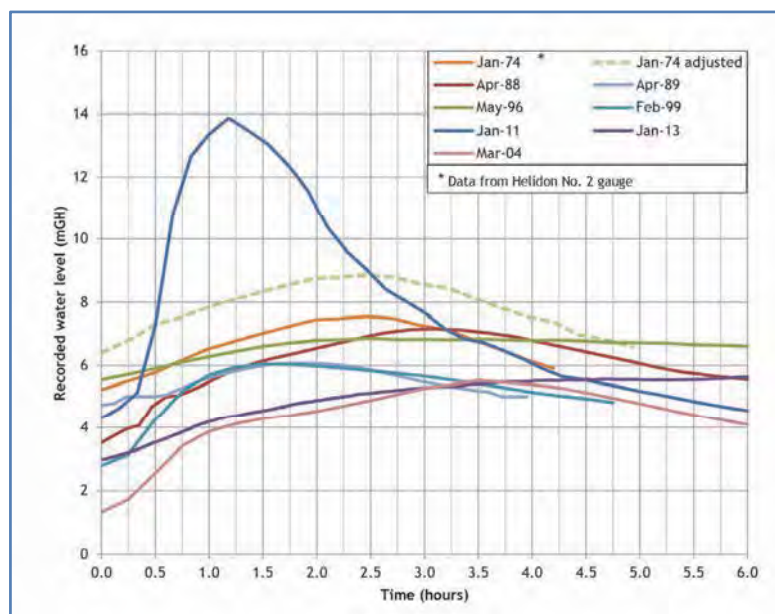

Figure 5.2: Comparison of recorded flood level hydrographs at Helidon
 Source: Exhibit 19, Dr David Newton, *Impact of the Grantham Sand Quarry on the January 2011 Flood in Grantham*, 3 July 2005 [p33: Figure 4.1].

Event	Recorded peak water level (meters GH)	Maximum rate of water level rise	
		meters per hour	meters per minute
Jan-74*	7.55	1.6	0.03
Jan-74 adjusted*	8.86	2.0	0.03
Apr-88	7.16	5.4	0.09
Apr-89	6.08	1.9	0.03
May-96	6.86	0.8	0.01
Feb-99	6.05	4.5	0.07
Mar-04	5.54	3.4	0.06
Jan-11	13.88	21.5	0.36
Jan-13	5.72	2.5	0.04

* Information shown in this table is based on recorded data at Helidon No. 3 gauge except for the Jan-74 event. The Jan-74 event data was recorded at Helidon No. 2 gauge, which is located about 2.7 km downstream of Helidon No. 3 gauge at the confluence of Monkey Water Holes.

Figure 5.3: Peak floodwater records for Helidon No. 3 gauge on Lockyer Creek.

Source: Exhibit 19, Dr David Newton, *Impact of the Grantham Sand Quarry on the January 2011 Flood in Grantham*, 3 July 2005 [p33: Figure 4.1].

- As is apparent, the level recorded on 10 January 2011 was almost double the highest level ever previously recorded. The rise in the Lockyer Creek was significant not only in terms of its magnitude but also its speed - **rising eight metres in the space of 30 minutes**.¹¹

The flooding on 11 January 2011

- There was also significant flooding that occurred in the Lockyer Valley on 11 January 2011.¹² However, that flooding was not of the same magnitude in Grantham as that of 10 January 2011 because the amount of rainfall upstream of Grantham was much less.¹³
- The rainfall on 11 January 2011 moved south-west and ultimately fell mainly into the catchments of Ma Ma Creek and Tenthill Creek, which discharge into the Lockyer Creek between Grantham and Gatton.¹⁴ As a consequence, Gatton experienced a double peak over those two days. First on 10 January 2011, from the surge down the Lockyer Creek due to the inundation of the Lockyer Creek's northern tributaries. Then a second rise on 11 January 2011 due to inundation of the Lockyer Creek's southern tributaries that are downstream of Grantham. This difference in the principal location of the rainfall accords with the water levels recorded at Helidon gauge no. 3 on 11 January 2011 where the maximum recorded water level on that day was 7.577 metres at 7:40 am.¹⁵ That is a very high water level that would produce significant flooding, but in the order of what occurred in 1974 rather than what happened on the preceding day.

The nature of the flooding of Grantham and its surrounds on 10 January 2011

- The flooding in and around Grantham on 10 January 2011 differed entirely from that which had previously been experienced by local residents.
- Within the memory of current residents, houses around the u-shaped bend of Lockyer Creek had not been inundated by flooding before 10 January 2011.¹⁶ However, on 10 January 2011, starting from about 3:45 pm, most of

the houses to the north of the bend, between the Lockyer Creek and Gatton-Helidon Road, were flooded as were all of the houses to the east, between Lockyer Creek and Grantham.

15. Dr John Macintosh, the expert water engineer engaged by the Commission, identified a number of houses near the Grantham sand plant, and marked in Figure 5.4, on which he focussed as part of his analysis. Of those marked houses, only the houses at 1703 Gatton-Helidon Road and 1665 Gatton-Helidon Road were not inundated on 10 January 2011. At 1665 Gatton-Helidon Road, the water came up to the house but did not get above the floorboards.¹⁷



Figure 5.4: Map showing location of houses near u-shaped bend considered by Dr Macintosh

Source: Exhibit 144, Dr John Macintosh, *Expert Hydrology Report – 10 January 2011 Flood – Circumstances and Contributing Factors – Supplementary Material No. 1*, 17 August 2015 [p11: Figure 1.2](amended)

16. As described in Chapter 1, the experience of Grantham residents before 10 January 2011 was that Grantham typically flooded when Lockyer Creek rose and caused Sandy Creek to back up; Sandy Creek would break its banks and slowly inundate the central area of Grantham.
17. However, eyewitnesses observed that Grantham flooded on the afternoon of 10 January 2011 in three stages. Dr Macintosh prepared diagrammatic representations of these three stages that appear as Figures 5.5, 5.6 and 5.7.
18. The first stage was the slow inundation of the central part of Grantham when Sandy Creek broke its banks. Dr Macintosh described this as the Sandy Creek surcharge. This was consistent with residents' previous experience of flooding in Grantham. This first stage began after 3:15 pm, but it took some time before Anzac Avenue was flooded and Sandy Creek Bridge was overtopped.



Figure 5.5: Diagram of first stage of flooding Grantham

Source: Exhibit 144, Dr John Macintosh, *Expert Hydrology Report – 10 January 2011 Flood – Circumstances and Contributing Factors*, 11 August 2015 [p21: Figure 1.3(a)].

19. The second stage of the flooding of Grantham occurred when Lockyer Creek broke its banks to the south-west of Grantham and water flowed overland from Lockyer Creek into the town. Dr Macintosh referred to this as the “south-western overbank flow”. The Lockyer Creek broke its banks to the south of Grantham after 3:30 pm on 10 January 2011 and the south-western overbank flow reached Gatton-Helidon Road at about 4:00 pm.¹⁸

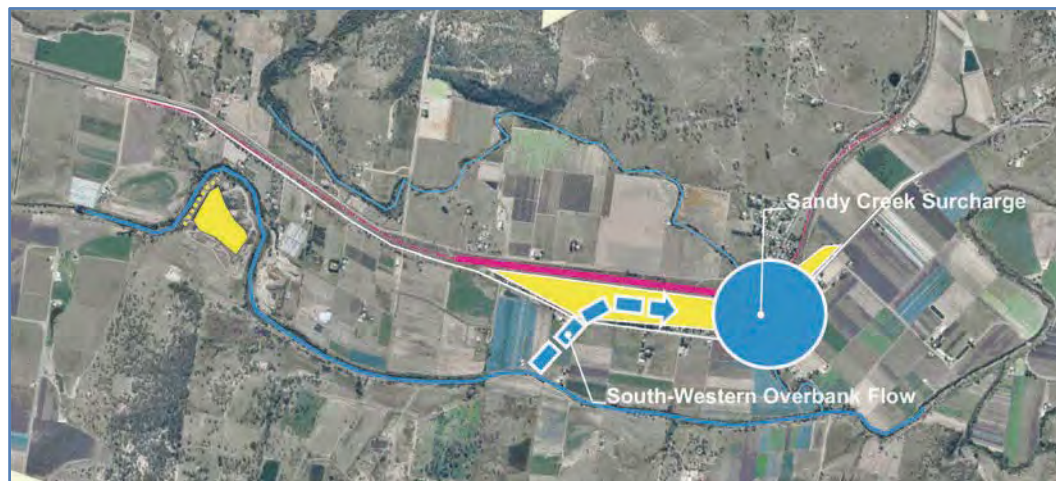

Figure 5.6: Diagram of second stage of flooding Grantham

Source: Exhibit 144, Dr John Macintosh, *Expert Hydrology Report – 10 January 2011 Flood – Circumstances and Contributing Factors*, 11 August 2015 [p21: Figure 1.3(b)].

20. The third stage of the flooding of Grantham occurred when the Lockyer Creek broke its banks on the eastern limb of the u-shaped bend. This created a second overland flow that hit Grantham from the west. Dr Macintosh referred to this as the “western overbank flow”. Lockyer Creek broke its eastern bank of the eastern limb of the u-shaped bend sometime after 3:30 pm¹⁹ and the western overbank flow reached the town of Grantham at about 4:10 pm.²⁰



Figure 5.7: Diagram of third stage of flooding Grantham

Source: Exhibit 144, Dr John Macintosh, *Expert Hydrology Report – 10 January 2011 Flood – Circumstances and Contributing Factors*, 11 August 2015 [p22: Figure 1.3(c)].

21. At the beginning of the third stage of the flooding, the railway line (marked in red on the diagrams) was stopping water from flowing across the floodplain to the north and instead forcing that water to travel to the east through Grantham.²¹ Sometime after 4:15 pm, the floodwaters in Grantham overtopped the railway line.²²
22. By around 4:30 pm, television news helicopters were flying over Grantham. Between about 4:30 pm and 4:40 pm, the channel 9 helicopter recorded the extent of the flooding in the area,²³ which stretched across the entire floodplain from the u-shaped bend of the Lockyer Creek to Grantham. This can be seen in Figure 5.8, in which Grantham is in the centre background and the submerged area of the quarry is in the right foreground.



Figure 5.8: – Extent of flooding recorded by channel 9 helicopter at some time between 4:30 pm and 4:40 pm

Source: Exhibit 69, channel 9 helicopter footage.

Expert investigations

Assistance of experts and the use of computer modelling

23. To assist me in the task of considering the effect of natural and man-made features of the landscape on the flooding of Grantham, the Commission engaged Dr John Macintosh, a water engineer, to provide an expert report. The Commission also engaged Mr Stefan Szykarski, who is a civil engineer specialising in water and environmental engineering, to review Dr Macintosh's work.
24. As part of his work, Dr Macintosh used computer modelling to evaluate the extent to which the quarry, the plant area and the railway line had an effect on the flooding of Grantham. Dr Macintosh noted the limitations of computer modelling in his report and evidence. The modelling is not reality. It is an approximation of reality and will rarely exactly match reality in all respects.²⁴ However, as Mr Szykarski noted, there was a very close correlation between Dr Macintosh's modelling and the surveyed peak water levels and the timing of flooding observed by eyewitnesses.²⁵ For example, there was an average difference of only six centimetres between Dr Macintosh's modelling of the peak flood heights in Grantham and in the area immediately surrounding the quarry when compared with the peak flood heights surveyed after the flood.²⁶
25. In addition, as Mr Szykarski also pointed out, the modelling is very accurate when it is used to compare the differences between scenarios.²⁷ For example, when used to analyse the effect of the quarry on the flooding of Grantham, by comparing scenarios with and without the quarry.
26. The extensive work undertaken by Dr Macintosh is summarised in Appendix C. It is sufficient for me to note here that the flooding as modelled by Dr Macintosh was based upon the water levels of the creeks recorded by gauges during the flood, and the terrain data recorded in August 2010 and February 2011 by LiDAR. It was corroborated against the surveyed peak flood levels; eyewitness observations as to flood heights and timing; and the many photographs and videos recorded during the flooding.
27. In the section that follows, I have used a number of images from one of Dr Macintosh's models to illustrate the progression of the flood. One of the few unknowns about what occurred on 10 January 2011 is the time and duration over which the bunds on the western side of the quarry collapsed. I have included images of Dr Macintosh's modelling based on what he considers the most likely progression of failure of the bunds. The model uses a colour-scale to indicate the intensity of the water. Intensity is the product of depth and velocity and is expressed in metres²/second (m²/s). The colour-scale used is indicated on Figure 5.9.
28. Mr Grantley Smith, Manager and Principal Engineer of the University of New South Wales' Water Research Laboratory, provided a report to the Commission concerning the stability of people, vehicles and buildings in floodwaters.²⁸ Mr Smith was the lead author on the guideline for assessing flood hazard that accompanied the national best practice manual on floodplain management.²⁹
29. Mr Smith explained in his report that when floodwaters exceed an intensity of 1 m²/s, "single story residential properties (e.g. fibro, cladded) are vulnerable to failure by the walls being pushed in from the weight and impact of the water". When floodwaters exceed an intensity of 2 m²/s, "most brick construction buildings would be liable to failure by the walls collapsing from the weight and impact of the water". In floodwaters at or exceeding 4 m²/s, "even the most robustly constructed concrete reinforced buildings are likely to fail in water depths" either due to the foundations being undermined or the uplift forces on the building causing failure of the walls and foundation slab.³⁰ Dr Macintosh's modelling shows that on 10 January 2011, at the flood's peak, the intensity of the floodwaters exceeded 2 m²/s throughout almost all of Grantham and exceeded 4 m²/s throughout much of Grantham.

Why the flooding of Grantham happened in the way that it did

The effect of the bunds before they were overtopped

30. Although the merged storm cell dumped rainfall into the upper catchment of the Lockyer Creek from about 1:00 pm on 10 January 2011, it took some time for the surge of water to travel downstream to the area of the Grantham quarry.
31. By about 3:15 pm on 10 January 2011, the Lockyer Creek had broken its banks immediately to the west of the Grantham quarry but had not yet overtopped the bunds on the western side of the quarry pit.³¹ In Grantham, Sandy Creek was on the verge of breaking out into the low-lying areas of the town, which would be the first stage of the flooding.

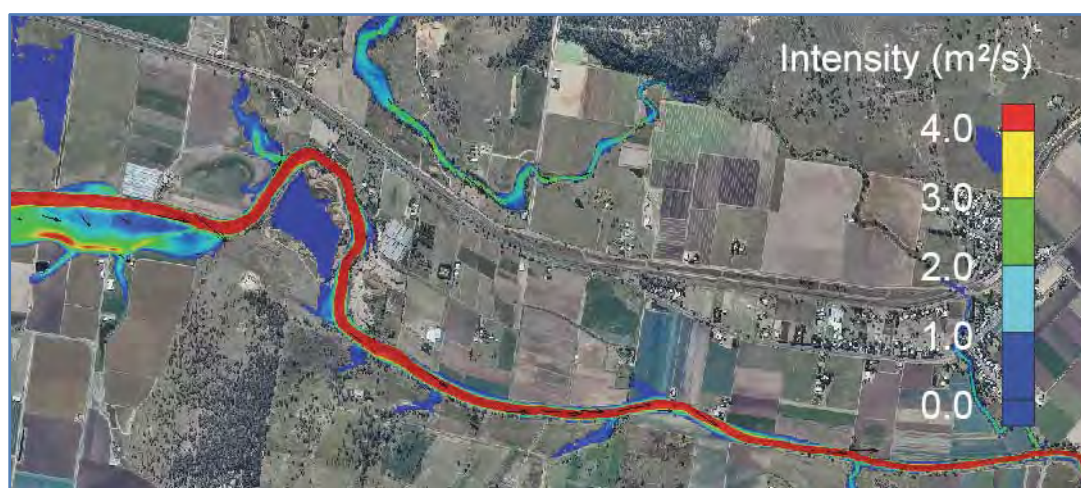

Figure 5.9: Image of modelled water levels at 3:15 pm on 10 January
Source: Exhibit 144, John Macintosh, Most likely scenario animation

32. The water coming down Lockyer Creek from its upper catchment caused it to rise. As Lockyer Creek rose along the western limb of the u-shaped bend, it broke its banks and began spilling water towards the Grantham quarry. The presence of the bunds delayed the point in time at which water could spill over into the quarry pit. However, the bunds were not a uniform height and so some parts of the bunds were overtopped at an earlier point than other parts.
33. While the bunds were blocking the overspill, water that would otherwise have flowed into the quarry pit was forced to go around the bunds to the north and south. Compared to what would have happened if the bunds were not present, this increased the water levels along those north and south paths and also lifted the water levels upstream.³² The highest lift in water levels due to the presence of the bunds was closest to the Grantham quarry, where Dr Macintosh determined that the presence of the bunds caused a lift in water levels of about 20 centimetres.³³ The lift in water levels then reduced to negligible over a distance of about two kilometres upstream of the quarry.³⁴
34. The effect of the presence of the bunds on the western side of the quarry pit was therefore to increase marginally the water levels immediately upstream of the Grantham quarry but only by about 20 centimetres. There is no evidence that would suggest that this increase was significant, in the sense of having had any material effect on the damage caused by the extensive flooding upstream of the quarry.

The effect of the bunds being overtopped and eroded

35. During the course of the flood, most of the western bund and the eastern bund were washed away by the floodwaters bringing the majority of the area between the western side of the quarry pit and Lockyer Creek back to the natural ground level. However, in the main breach area identified in Figure 5.11, a deep trough, down to the bed level of Lockyer Creek, was scoured into the bank separating the quarry pit from Lockyer Creek.³⁵ The change along that western end of the quarry pit can be seen by comparing Figure 5.10, which is an oblique view across the quarry pit before the flooding, with Figure 5.11, which is the same view after the flooding.



Figure 5.10: Oblique view before 10 January 2011

Source: Exhibit 144, Dr John Macintosh, *Expert Hydrology Report – 10 January 2011 Flood – Circumstances and Contributing Factors*, 11 August 2015 [p66: Figure 8.12] (amended)



Figure 5.11: Oblique view after 10 January 2011

Source: Exhibit 144, Dr John Macintosh, *Expert Hydrology Report – 10 January 2011 Flood – Circumstances and Contributing Factors*, 11 August 2015 [p67: Figure 8.13] (amended)

36. Dr Macintosh prepared a diagram, reproduced as Figure 5.12, showing the profile of the eastern bund before and after the flood. The zero metre point on the horizontal scale of this figure is the southern end of the bund. The area of the main breach is at about 350 metres to 400 metres on the horizontal scale. That area was the lowest to begin with and therefore the first to be overtopped.

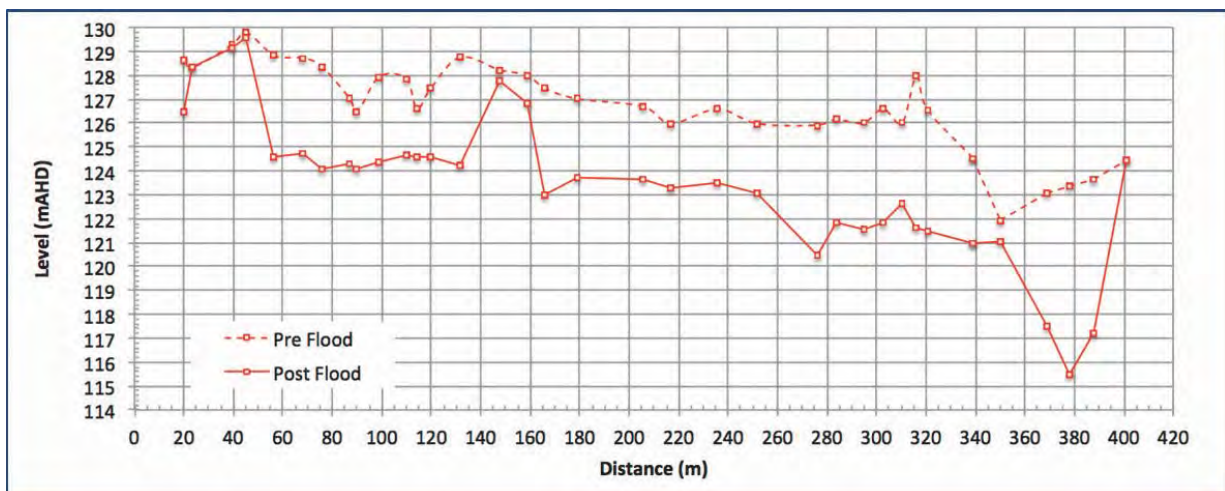

Figure 5.12: Pre and post-flood profile for the eastern bund

Source: Exhibit 144, Dr John Macintosh, *Expert Hydrology Report – 10 January 2011 Flood – Circumstances and Contributing Factors*, 11 August 2015 [p71: Figure 8.18].

37. Dr Macintosh’s opinion, based on his inspection of the site, consideration of photographs and post-flood aerial images and his experience, was that the most likely mechanism by which the bunds were removed was top down

erosion.³⁶ However, Dr Macintosh also determined that whether the bunds were eroded or collapsed suddenly from slip failure would have made no material difference to how the flooding unfolded.³⁷

38. He calculated, based on the volume of material removed, that the main breach area would have taken about five minutes after it was overtopped to erode the trench that was visible after the flood.³⁸ The removal of the remainder of the bunds would have taken about 14 minutes from when they were overtopped.³⁹
39. It was at about 3:25 pm that the Lockyer Creek rose to the point at which it overtopped the area where the main breach occurred. Water then began spilling into the quarry pit in the north-west corner of the pit. Dr Macintosh's view was that it was at this point that the erosion of the area of the main breach began. The erosion of the remainder of the eastern bund commenced slightly later, once the remainder of the bund was overtopped.



Figure 5.13: Image of modelled water levels at 3:25 pm on 10 January 2011
Source: Exhibit 144, John Macintosh, Most likely scenario animation

40. The quarry pit had an approximate surface area of 10 hectares⁴⁰ and was not full of water when the bunds were first overtopped. As a consequence, it had the capacity to absorb part of the flow and the extent of that absorption would depend upon the water level in the pit before it started to fill. There was no witness who had observed the level of water in the pit immediately before the flooding on the afternoon of 10 January 2011. However based, among other things, on the rainfall over the preceding month, Dr Macintosh determined that the highest reasonable estimate of the level of water in the pit when the flooding began on 10 January 2011 was 117.8 metres AHD.⁴¹ This meant that the water level in the pit needed to rise about another 4.2 metres before it was higher than the lowest edge of the pit, which was in the south-eastern corner.⁴² However, in his modelling, Dr Macintosh used a conservative lake level of 120 metres AHD. At the time that the main breach area was overtopped, the pit was being backfilled in the south-eastern corner from the Lockyer Creek.⁴³ Once the water in the pit rose above the lowest edge, water from the quarry pit would start flowing back out of the pit in that corner.⁴⁴
41. As a consequence, when the bunds failed and water poured into the pit, the inflow was initially absorbed by the pit. Once the water level in the pit rose above about 122 metres AHD, the water spilled over the southeast corner of the quarry pit and scoured a path back into the Lockyer Creek. Dr Macintosh identified a scour path in this south-eastern corner when he conducted an inspection of the site of the Grantham quarry. It is depicted in Figure 5.14.

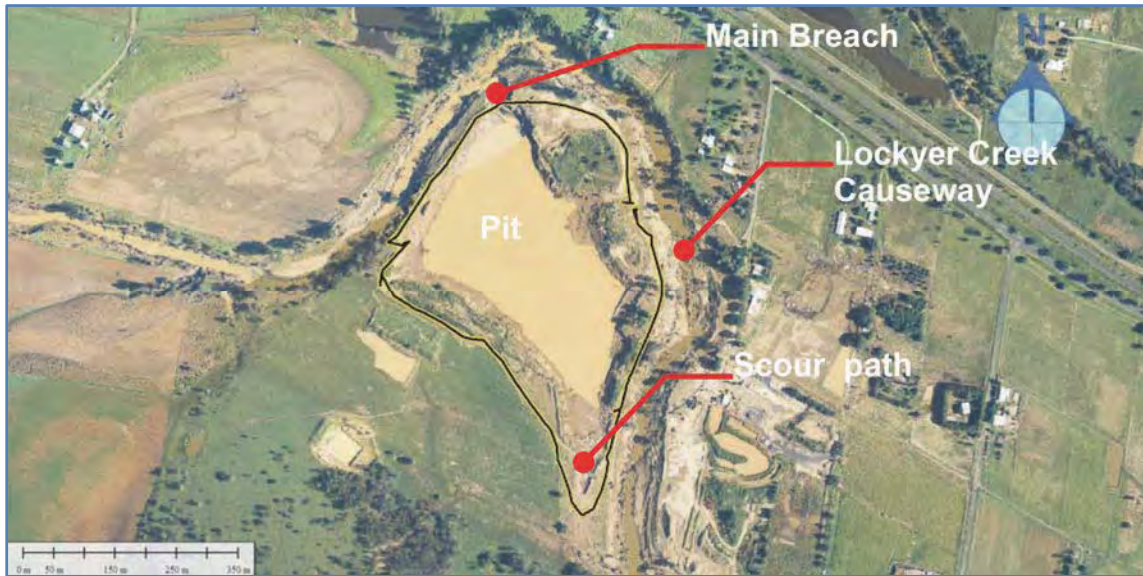

Figure 5.14: Image of Grantham quarry site identifying scour path in south-eastern corner of quarry pit.
Source: Exhibit 144, Dr John Macintosh, *Expert Hydrology Report – 10 January 2011 Flood – Circumstances and Contributing Factors*, 11 August 2015 [p43: Figure 6.1] (amended).

42. The water's path in the area of the Grantham quarry, from the north-west corner, where a trough was scoured through the main breach area, down to the south-eastern corner, would have been substantially the same with or without the quarry. That can be seen in Figure 5.15, which identifies the relevant features of the pre-quarry terrain.



Figure 5.15: Image of u-shaped bend before the quarry pit was excavated
Source: Exhibit 144, Dr John Macintosh, *Expert Hydrology Report – 10 January 2011 Flood – Circumstances and Contributing Factors*, 11 August 2015 [p96: Figure 10.6(a)].

43. Before the quarry pit was excavated there was a low point in the north-western corner, in the area where the main breach developed. A shallow depression ran from that north-western corner down to the south-east. In the south-

eastern corner of what is now the area of the Grantham quarry, there was what appeared to Dr Macintosh to be the remnant depression from an ancient water course.⁴⁵ That was the path that was scoured out on 10 January 2011.

44. Consequently, whether the bunds were there or not, and whether the quarry pit was there or not, water that spilled over into that area of the Grantham quarry from the western limb of the bend of Lockyer Creek would have taken the same course. It would have travelled predominantly from the northwest, where the bank of the creek was the lowest on the upstream side, to the southeast, where the land dipped and allowed the water to rejoin the flow of the Creek where it resumed its course to the east.
45. Some people have suspected that the collapse of the bunds might have caused a surge of water travelling directly from west to east across the face of the quarry pit and becoming the western overbank flow on the other side of the Lockyer Creek. That could not have occurred. Rather, the initial inflow into the quarry pit when the bunds were first overtopped was absorbed by the free capacity in the quarry pit and then the lay of the land directed the principal flow through the area of the Grantham quarry from the northwest to the southeast.
46. The western overbank flow was a product of other parts of the mechanics of the flood on 10 January 2011. As I explain below, the effect of the quarry on the western overbank flow, and to a more limited extent the effect of the quarry on the south-west overbank flow, was to delay the commencement of the flow by an insignificant few minutes at around 3:45 pm. That was because by or at this time the quarry pit absorbed part of the flow surging down the Lockyer Creek and the water that was absorbed would otherwise have contributed to the rise of the Lockyer Creek on the downstream side of the u-shaped bend.

The cause of the western overbank flow

47. By 3:40 pm, the Lockyer Creek had broken its eastern bank along parts of the eastern limb of the u-shaped bend. The water had not yet reached the houses at 1649 Gatton-Helidon Road or 1617 Gatton-Helidon Road.

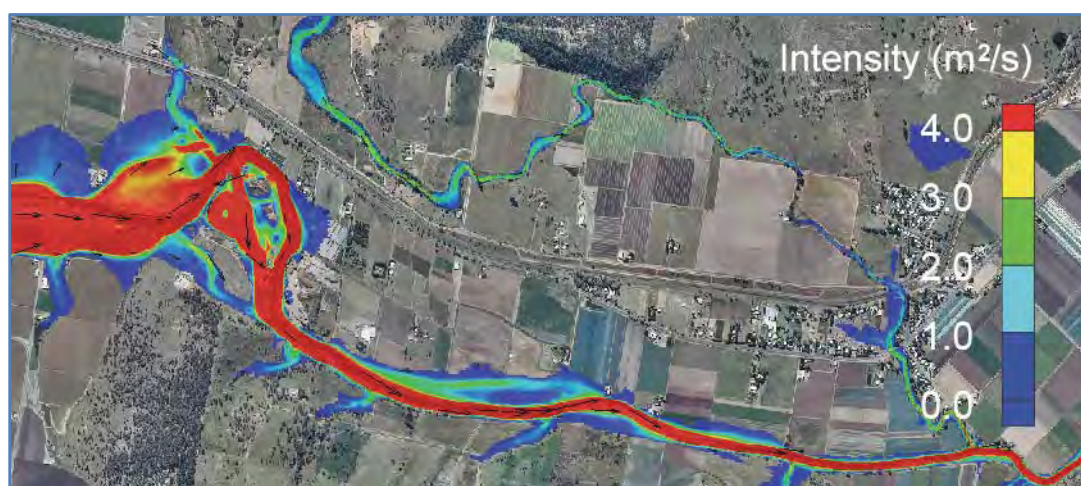

Figure 5.16: Image of modelled water levels at 3:40 pm on 10 January 2011
Source: Exhibit 144, Dr John Macintosh, Animation of most likely scenario.

48. The lowest point along that eastern bank, and therefore the first point overtopped by the Lockyer Creek, was the causeway that crosses the Lockyer Creek between the area of the Grantham quarry and Quarry Access Road. This is identified in Figure 5.10.
49. Dr Macintosh also prepared a cross-section along Quarry Access Road, reproduced as Figure 5.16. The crest of Quarry Access Road is at about 125 metres AHD. The dip for the causeway is apparent from that cross-section.

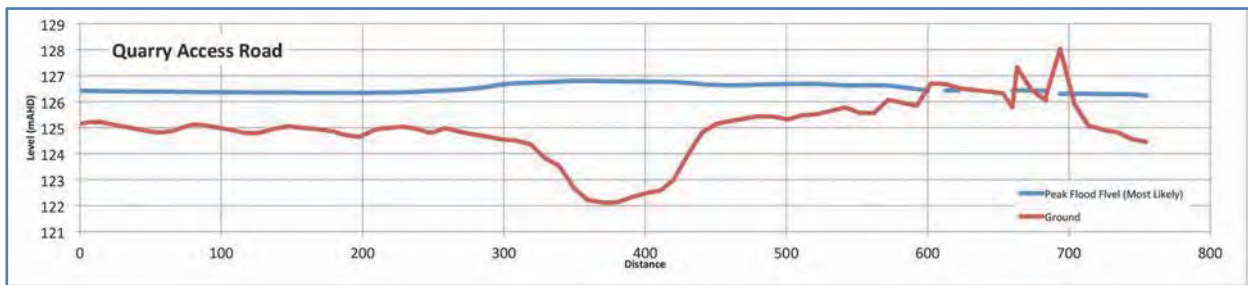

Figure 5.17: Cross-section from north to south along Quarry Access Road
 Source: Exhibit 162, Dr John Macintosh, Cross-section – western overbank breakout sections.

50. However, even if there had been no causeway and no dip, and all of the area of the causeway was lifted up to 125 metres AHD to become level with the crest of Quarry Access Road, the western overbank flow would still have occurred.⁴⁶ That is because Lockyer Creek not only rose high enough to break its banks on the eastern limb of the u-shaped bend but also for water to overtop the crest of Quarry Access Road. Even if the area of the causeway had been lifted to 125 metres AHD, it would still have been overtopped.
51. Once the water had overtopped Quarry Access Road, the land between Quarry Access Road and Grantham fell about seven metres over almost 2.5 kilometres. Dr Macintosh prepared a profile of the western overbank flow showing the fall in the land towards Grantham and the probable height of the water along that profile at different times on the afternoon of 10 January 2011.

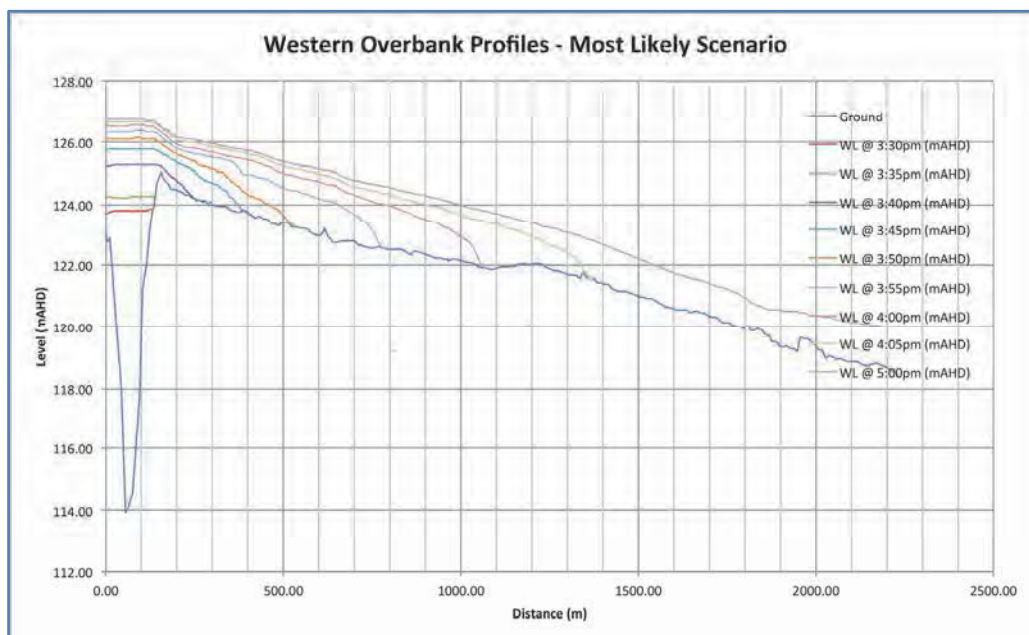

Figure 5.18: Western overbank flow profiles
 Source: Exhibit 159, Dr John Macintosh, Western Bank profiles

52. The presence of the plant operations, at the Grantham sand plant, on the eastern side of the u-shaped bend did not have any significant effect on the western overbank flow. The path of the western overbank flow was principally the product of a natural channel between Gatton-Helidon Road, to the north, and the Lockyer Creek, to the south, that directed the western overbank flow into Grantham.⁴⁷ The shape of that natural channel is most apparent from a cross section of Dorrs Road prepared by Dr Macintosh, which is Figure 5.20. Dorrs Road is about 500 metres to the

east of Quarry Access Road. Zero metres on the horizontal axis of that Figure is approximately the location of Gattton-Helidon Road.

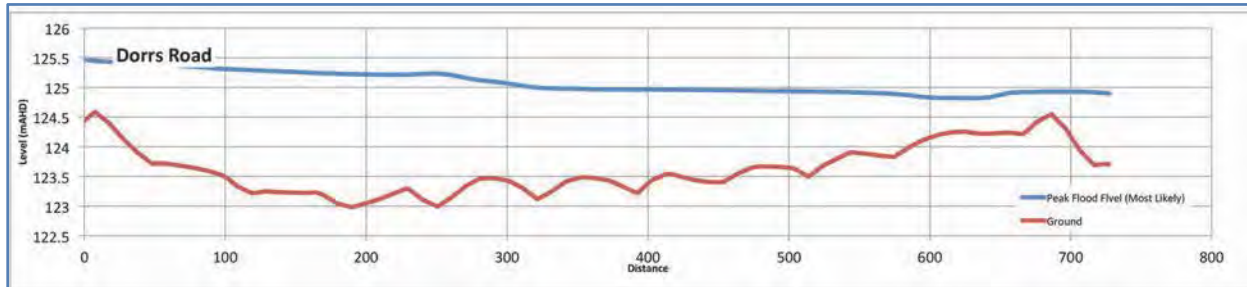

Figure 5.19: Cross-section from north to south along Dorrs Road

Source: Exhibit 162, Dr John Macintosh, Cross-section – western overbank breakout sections.

53. The railway embankment contributed to the channeling of the western overbank flow. The railway embankment held water that might have otherwise spread further north to within this natural channel.
54. The combined effect of the natural channel and the railway was that once Lockyer Creek had risen to the point where water had overtopped Quarry Access Road, the shape of the land funneled the water towards Grantham. If the ground where the plant operations had been established had been slightly lower, that area would have been inundated slightly earlier than in fact occurred but the water would then have been directed by the shape of the land into this natural channel.
55. Dr Macintosh modelled the volume of water discharged along this western overbank flow path and compared the situation with the Grantham quarry as it was, with the situation as it would have been with the quarry pit and bunds removed and with the whole of the Grantham sand plant (comprising the quarry and plant area) removed. The results can be seen in Figure 5.20.

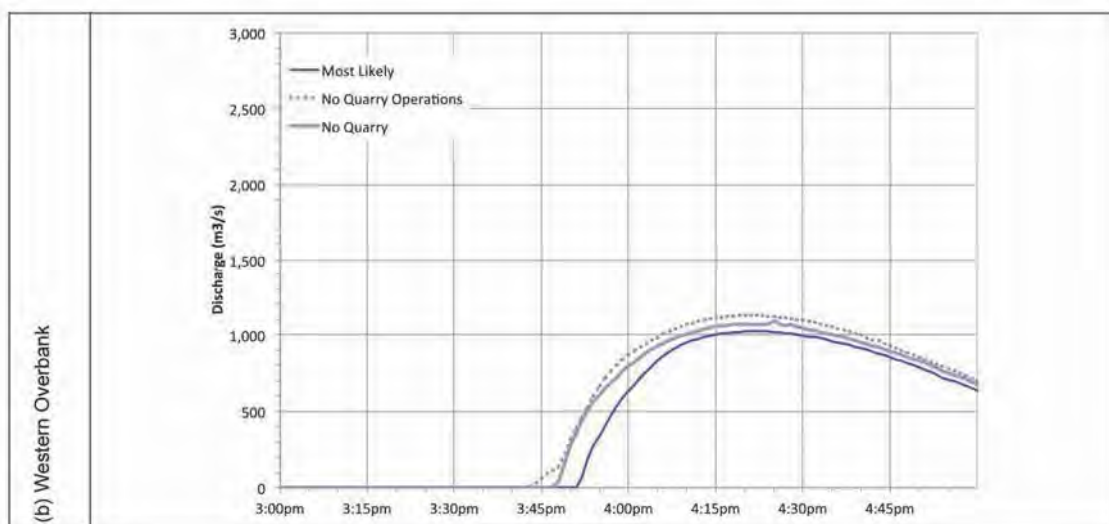

Figure 5.20: – Western overbank flow

Source: Exhibit 304, Dr John Macintosh, *Expert Hydrology Report – 10 January 2011 Flood – Circumstances and Contributing Factors – Supplementary Material No. 2*, 3 September 2015 [p22: Figure 3.3(b)].

56. Reducing the ground level of the plant area would increase the western overbank flow,⁴⁸ which is the flow that hit Grantham from the west. On the other hand, the existence of the quarry pit slightly delayed the start of the western overbank flow by a few minutes. That was because for a brief period, after the bunds were overtopped but before the quarry pit was full, the pit absorbed part of the flow that would otherwise have travelled down the Lockyer Creek. This delayed the rise of the Lockyer Creek along the eastern limb of the u-shaped bend and so delayed the time at which the Lockyer Creek rose sufficiently high for water to overtop Quarry Access Road and thereby begin to course down the natural channel towards Grantham.
57. By 3:57 pm, the western overbank flow was streaming down the natural channel towards Grantham and had almost reached a white shed located about midway between Dorrs Road and Charles Road.

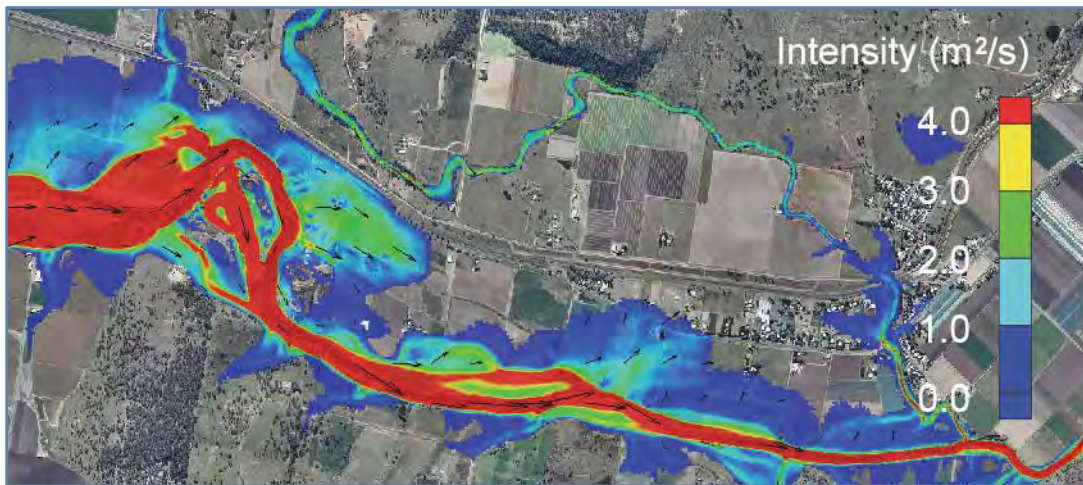

Figure 5.21: Image of modelled water levels at 3:57 pm on 10 January 2011.
Source: Exhibit 144, Dr John Macintosh. Animation of most likely scenario.

58. A photographer on the southern side of Lockyer Creek took a photograph at 3:57 pm that captured the western overbank flow as it neared that white shed.

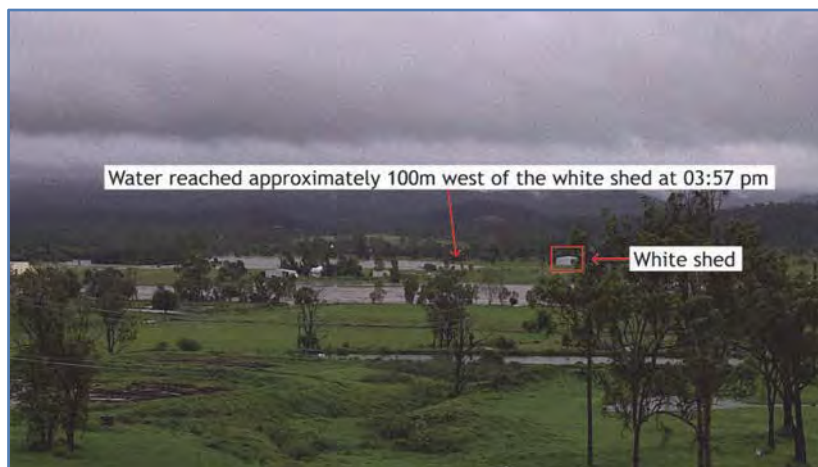

Figure 5.22: Image of western overbank flow at 3:57 pm
Source: Exhibit 167, Dr David Newton, Validation mp4

59. Although the western overbank flow had not yet reached Grantham, the south-western overbank flow had already crossed part of Gatton-Helidon Road and the rising Lockyer Creek had caused Sandy Creek to back up and inundate low-lying areas of central Grantham.

The cause of the south-western overbank flow

60. As the Lockyer Creek rose, it eventually broke its banks to the south-west of Grantham. From the bank of the Lockyer Creek, the land falls about 1.5 metres from south to north to Gatton-Helidon Road.⁴⁹ Consequently, the slope of the land directed the water spilling out from the Lockyer Creek straight towards Grantham.
61. Dr Macintosh also modelled the volume of water discharged along this south-western overbank path and compared the same three situations he used for considering the western overbank flow. The results for the south-western overbank flow can be seen in Figure 5.23.

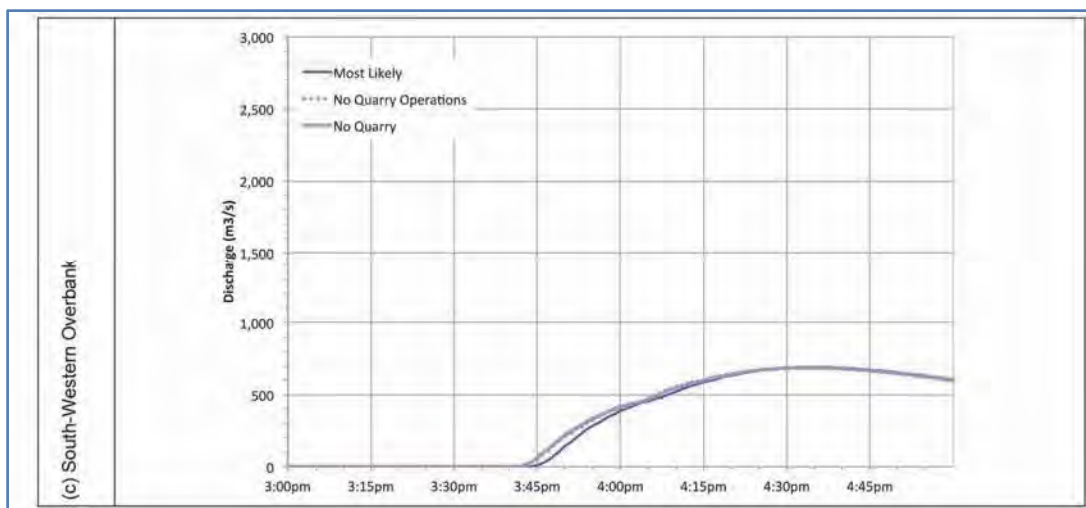

Figure 5.23: South-western overbank flow.

Source: Exhibit 304, Dr John Macintosh, *Expert Hydrology Report – 10 January 2011 Flood – Circumstances and Contributing Factors – Supplementary Material No. 2*, 3 September 2015 [p22: Figure 3.3(c)].

62. As with the western overbank flow, the quarry pit very slightly delayed the south-western overbank flow and for the same reason. While the pit filled, it absorbed part of the flow that would otherwise have travelled down the Lockyer Creek. That delayed by a few minutes the point at which the Lockyer Creek rose sufficiently high to break its banks to the south of Grantham.

The effect of the railway line

63. Just before 4:10 pm, the south-western overbank flow had passed through Grantham and hit the railway line. When that flow hit the railway it was turned to the east rather than continuing through to the northern side of the railway embankment. At about the same time, the western overbank flow was just arriving at the eastern edge of Grantham, having travelled down the natural channel from Quarry Access Road to Grantham, to join the water that would otherwise have spread to the north.

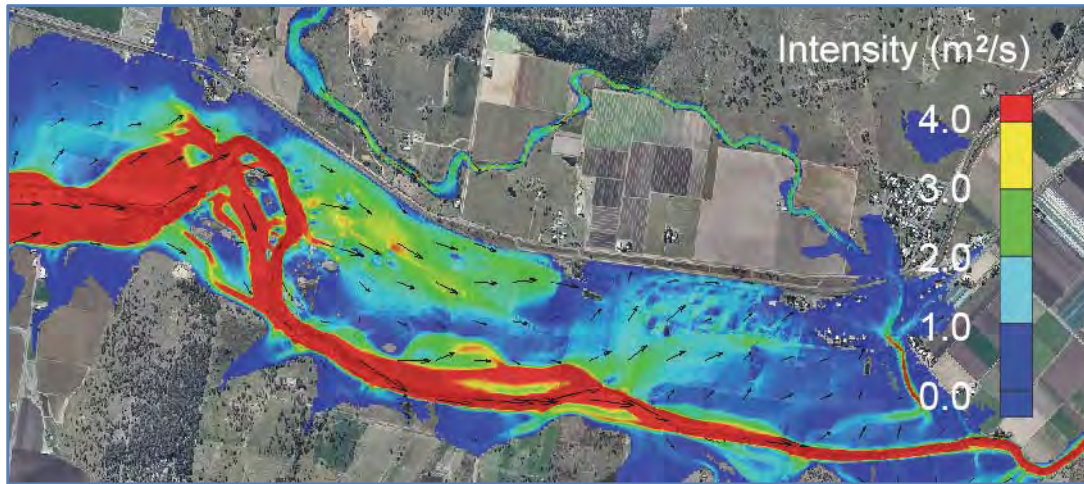

Figure 5.24: Image of modelled water levels at 4:07 pm on 10 January 2011
 Source: Exhibit 304, John Macintosh, Most likely scenario animation

- 64. The railway embankment had the effect of increasing the volume, and therefore intensity, of the amount of water in Grantham from both the western overbank flow and the south-western overbank flow. However, considered in context, the increase was not significant.
- 65. Dr Macintosh modelled the changes to depth, velocity and intensity from removing just that part of the railway embankment that bordered the town of Grantham, and also the changes from removing the whole railway embankment, extending to the west of the quarry and the east of Grantham. The average maximum depth, velocity and intensity in the area of Grantham to the west of Sandy Creek are set out in Table 5.1.

	With Railway	No railway embankment bordering Grantham		No railway embankment from west of the quarry to east of Grantham	
	Maximum	Maximum	Change	Maximum	Change
Average Intensity (m x m/s)	2.8	2.3	-0.5	2.2	-0.6
Average Depth (m)	2.6	2.4	-0.2	2.3	-0.3
Average Velocity (m/s)	1.2	1.1	-0.1	1.1	-0.1

Table 5.1: Table showing comparison of effect of railway line on intensity, depth and velocity in Grantham.
 Source: Exhibit 304, Dr John Macintosh, *Expert Hydrology Report – 10 January 2011 Flood – Circumstances and Contributing Factors – Supplementary Material No. 2*, 3 September 2015 [p33: Table 4.1]

- 66. The average of the maximum intensity of the floodwaters in Grantham would have exceeded 2.0m²/s regardless how much of the railway embankment was removed. That is an intensity described by Mr Szylkarski as an “extreme condition”.⁵⁰ It is also the level that Mr Smith explained meant that a house in a flood 20 metres wide was “exposed to a similar force to being hit by a 40 tonne semi-trailer every 15 seconds”.⁵¹
- 67. The presence of the railway line did not cause the flooding of Grantham and, while it slightly exacerbated the intensity of the flooding, did not materially affect the flooding that would have been, in any event, extreme.

The effect of the Grantham quarry on evacuation

68. Dr Macintosh identified three potential evacuation routes from Grantham. They are identified in Figure 5.25.

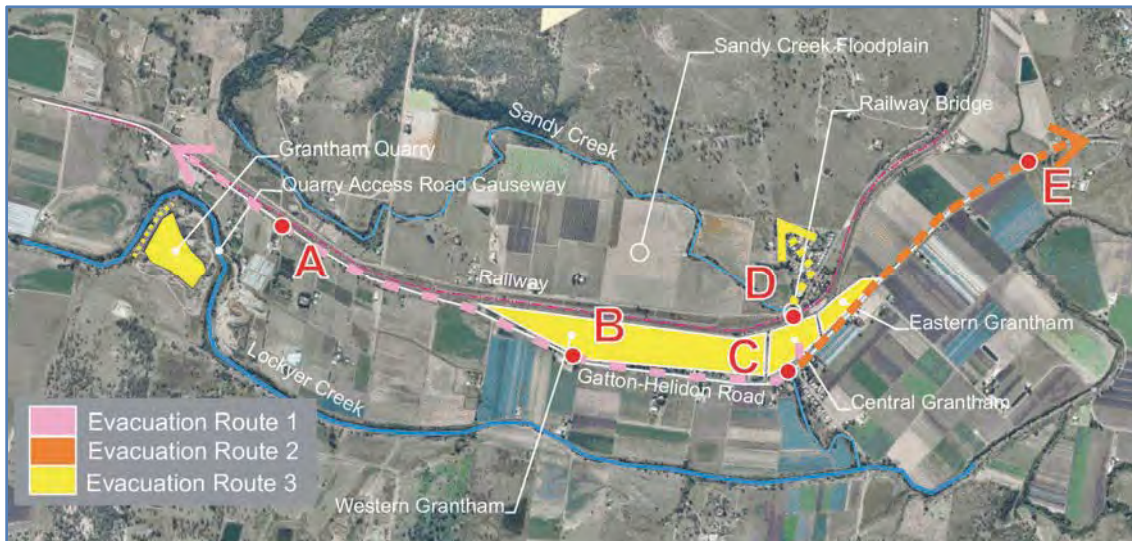

Figure 5.25: Image identifying potential evacuation routes from Grantham

Source: Exhibit 144, Dr John Macintosh, *Expert Hydrology Report – 10 January 2011 Flood – Circumstances and Contributing Factors*, 11 August 2015 [p35: Figure 1.12].

69. Dr Macintosh considered that it was likely that each of these evacuation routes would be closed at the point when floodwaters reached a depth of 0.3 metres or an intensity of $0.5 \text{ m}^2/\text{s}$.⁵² Dr Macintosh's modelling showed that each evacuation route was closed by up to a few minutes later than it would have been if there had been no Grantham quarry. However, as most of the residents of Grantham were only made aware that they needed to flee when they saw the impending floodwaters, the delay in the flooding was of no significance to any possible evacuation.

The effect of the quarry on damage to property

70. By 4:35 pm, the flooding of Grantham was at or nearing its peak. The intensity of the floodwater in Grantham was extreme. It destroyed concrete structures⁵³ and caused significant damage to, and in one case the collapse of, buildings.⁵⁴

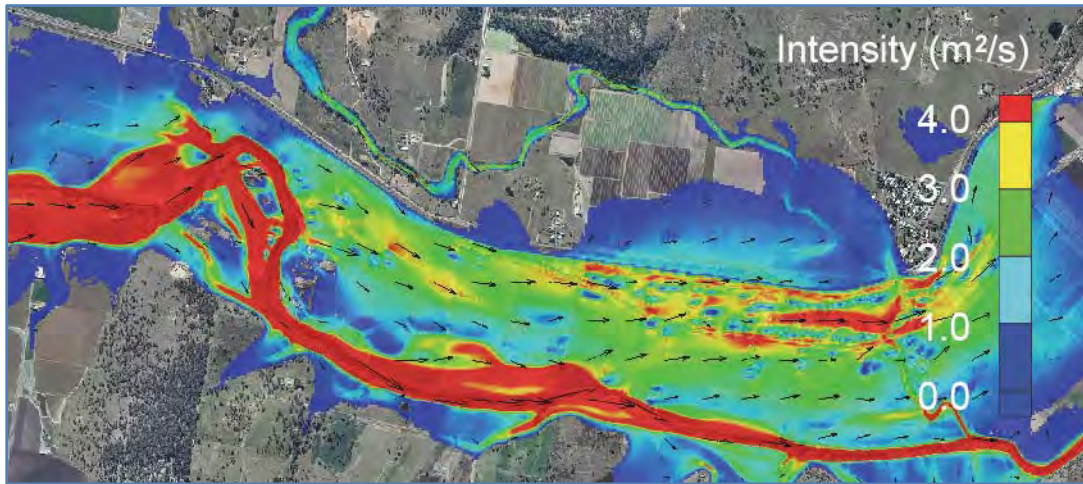

Figure 5.26: Image of modelled water levels at 4:35 pm on 10 January 2011
 Source: Exhibit 304, John Macintosh, Most likely scenario animation

71. Dr Macintosh calculated that over the period from just before 4:00 pm to 8:00 pm on the afternoon of 10 January 2011, six gigalitres of water passed through the area of Grantham to the west of Sandy Creek.⁵⁵ That is six million tonnes of water passing through Grantham over a little over four hours. The total volume of water that passed by Grantham from about 2:00 pm to 8:00 pm on 10 January 2011 was 32 gigalitres or 32 million tonnes of water.⁵⁶
72. As Mr Szylkarksi noted, with or without the quarry, the flooding in Grantham would have exceeded an extreme condition.⁵⁷ Dr Macintosh's modelling enables a comparison to be made of the differences in depth, velocity and intensity that would have resulted at different places in and near Grantham if the quarry had not existed. That modelling shows that there would be no material change to the intensity of the flooding, its depth or its velocity in Grantham or at any of the locations near the quarry that were examined by Dr Macintosh.
73. The results at four locations illustrate this: 1649 Gatton-Helidon Road, to the north of the quarry; 1617 Gatton-Helidon Road, to the east of the quarry; 1414 Gatton-Helidon Road, at the western end of Grantham; and 26 Anzac Avenue, at the eastern end of Grantham. Set out below in Figures 5.28 to 5.31, are the maximum points in terms of depth and velocity, as calculated by Dr Macintosh, marked on the Flood Hazard Vulnerability Curve.⁵⁸
74. The relevant locations are marked in Figure 5.27.



Figure 5.27: Map identifying four locations for Figures 5.28 to 5.31

Source: Exhibit 144, Dr John Macintosh, *Expert Hydrology Report – 10 January 2011 Flood – Circumstances and Contributing Factors – Supplementary Material No. 1*, 17 August 2015 [p11: Figure 1.2](amended)

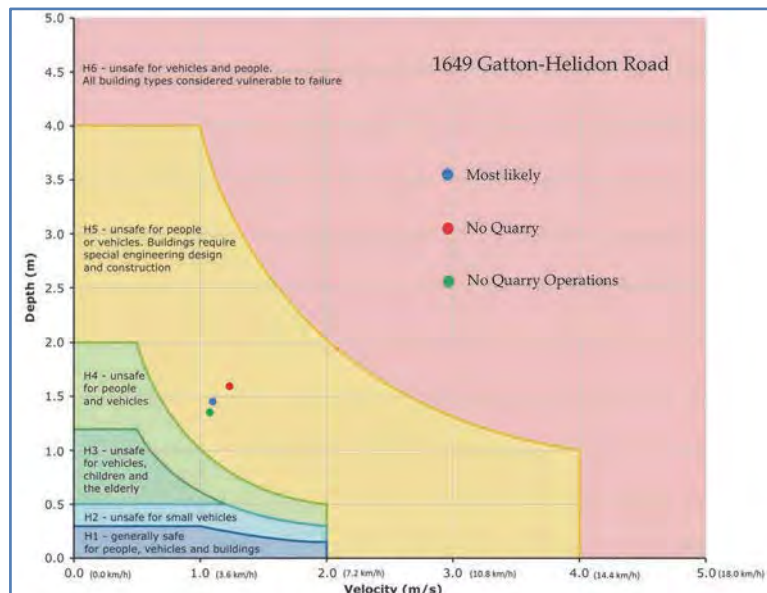

Figure 5.28: Depth, velocity, intensity and hazard at 1649 Gatton-Helidon Road

Source: Exhibit 142, Grantley Smith, *Expert Opinion: Stability of People, Vehicles and Buildings in Flood Water*, 13 August 2015 [p6: Figure 3] (amended)

75. The house at 1649 Gatton-Helidon Road was on stumps about a foot high and water entered it through the windows.⁵⁹ The house appeared to have been lifted from the top of its stumps. The carport was severely damaged.

The concrete slabs were lifted and turned and the roof of the carport had bowed in from the force of the water. The sheds had been filled with mud, the fences torn away and a demountable office had been moved a couple of hundred metres into a neighbour's tree.⁶⁰

76. The evidence does not suggest that this damage would have been materially lessened if the Grantham quarry itself, or the plant area on the other side of the Lockyer Creek, had been removed. The intensity of the floodwaters at this location would have in any event been classified as a level of H5 (see Figure 5.28) on the Hazard Vulnerability Curve, meaning the floodwaters were unsafe for people or vehicles and buildings would require special engineering design and construction if they were not to be at risk of failure.
77. The house at 1617 Gatton-Helidon Road was destroyed, and there was significant damage to the wall on the western side of a shed on the property. A car in the shed was washed onto Gatton-Helidon Road, and a 12 tonne crane was shifted about 20 to 30 metres to the east.⁶¹ As with the house at 1649 Gatton-Helidon Road, regardless of the presence of the quarry, the flooding at 1617 Gatton-Helidon Road was categorised as H5 (see Figure 5.29) on the Hazard Vulnerability Curve. This was above a level where buildings were vulnerable to failure by the walls being pushed in from the weight and impact of the water.
78. The evidence does not suggest any factor materially contributed to the damage at 1617 Gatton-Helidon Road other than the volume of water surging down the Lockyer Creek from its upper catchment.
79. At 1414 Gatton-Helidon Road (see Figure 5.30), the floodwaters reached an intensity where “most brick construction buildings would be liable to failure by the walls collapsing from the weight and impact of the water”.⁶² At 26 Anzac Avenue (see Figure 5.31), the floodwaters verged on an intensity such that “even the most robustly constructed concrete reinforced buildings are vulnerable to failure”.⁶³ The presence of the quarry, or the quarry operations, had no material effect on this intensity.
80. Neither the quarry, nor the buildings and materials at the plant area on the eastern side of the u-shaped bend of the Lockyer Creek, materially contributed to the damage caused in Grantham or near the quarry by the flooding on 10 January 2011.

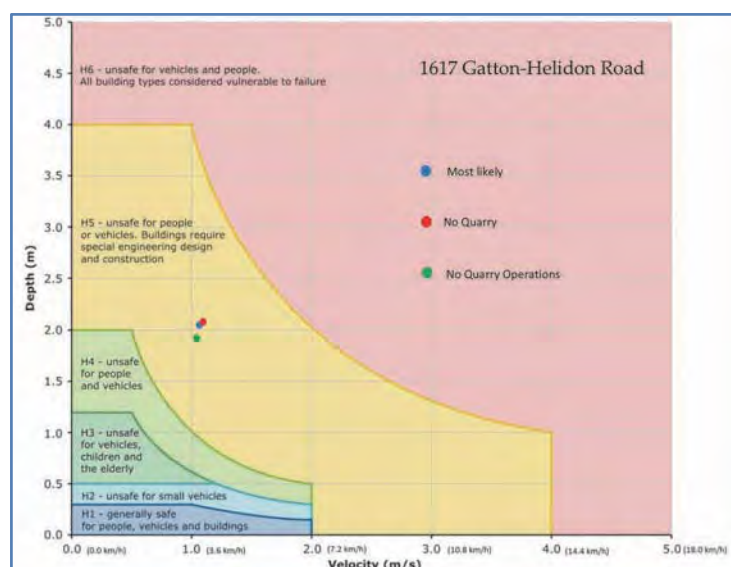

Figure 5.29: Depth, velocity, intensity and hazard at 1617 Gatton-Helidon Road
 Source: Exhibit 142, Grantley Smith, *Expert Opinion: Stability of People, Vehicles and Buildings in Flood Water*, 13 August 2015 [p6: Figure 3] (amended)

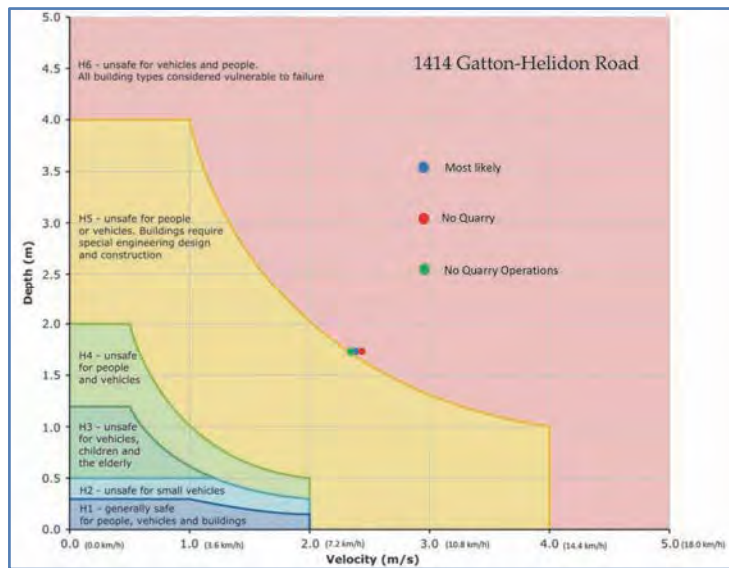

Figure 5.30: Depth, velocity, intensity and hazard at 1414 Gatton-Helidon Road
 Source: Exhibit 142, Grantley Smith, *Expert Opinion: Stability of People, Vehicles and Buildings in Flood Water*, 13 August 2015 [p6: Figure 3] (amended)

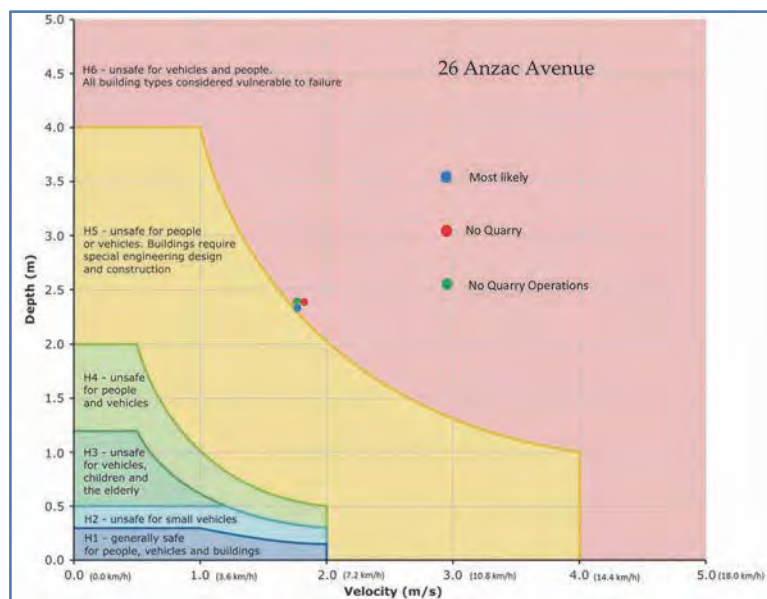

Figure 5.31: Depth, velocity, intensity and hazard at 26 Anzac Avenue
 Source: Exhibit 142, Grantley Smith, *Expert Opinion: Stability of People, Vehicles and Buildings in Flood Water*, 13 August 2015 [p6: Figure 3] (amended)

Cause of the flooding of Grantham

81. Grantham flooded on 10 January 2011 in the way that it did because of the combination of the volume of water that surged down Lockyer Creek that afternoon and the natural shape of the land near Grantham.
82. The first stage of the flooding was not a surprise to the residents. Sandy Creek had not infrequently flooded the town in the past when the Lockyer Creek rose.

83. The second stage of the flooding was a consequence of the Lockyer Creek rising to a sufficient level that it broke its banks to the south-west of Grantham. That required a significant surge of water down the Lockyer Creek. That surge was caused by the rain that had been dumped in the upper catchment of the Lockyer Creek earlier in the afternoon into a saturated catchment. The only effect of the quarry on this second stage of the flooding was to slightly delay its commencement by up to a few minutes because the quarry pit briefly absorbed part of the flow.
84. The third stage of the flooding was due to Lockyer Creek rising in the u-shaped bend to the point where it overtopped Quarry Access Road and water was then funnelled by a natural channel towards Grantham to the east. This flow took the residents of Grantham by surprise and dramatically exacerbated the already dangerous flooding of the town. As with the flow from the south, the only effect of the quarry on this second stage of the flooding was to delay its commencement by up to a few minutes while the quarry pit absorbed part of the flow coming down the Lockyer Creek and so delay of the moment at which the waters overtopped Quarry Access Road.
85. These conclusions are shared by Dr Macintosh, Dr Newton, Mr Szylkarski and Dr Jordan. No party has submitted to me that they are wrong or even affected by the slightest doubt.
86. I should say something about the earlier hydrology work done by Dr Phillip Jordan for the Queensland Floods Commission of Inquiry⁶⁴. Dr Jordan is a highly experienced hydrologist. He has a bachelor of engineering degree and a PhD earned in the field of flood hydrology. He has been working in this field since 1994.
87. Dr Jordan was retained by the Queensland Floods Commission of Inquiry to prepare a report concerning the flash floods in both Toowoomba and in the Lockyer Valley. He was subsequently requested to examine whether the Grantham quarry had had any effect upon the flooding in Grantham.
88. Dr Jordan's conclusions concerning the causes of the flooding in Grantham accorded with the opinions later expressed by Dr Macintosh and Mr Szylkarski and which I have set out above. However, his reports have been the subject of some criticism. In fairness to Dr Jordan, it must be said that these criticisms, while they might have appeared at one point to have had a basis, have been shown, by the evidence of the experts who have testified before me, to have no real substance.
89. I do not think it is necessary for me to address every criticism that has been made about Dr Jordan's reports, although I deal with them in slightly greater detail in Appendix C. Here I will deal with one example in order to balance the scales.
90. Dr Jordan had performed modeling of the same kind as Dr Macintosh. To do this, he used terrain surveys showing the topography around the quarry before and after the flood. These accurately showed, of course, the western embankment at both points of time. As Dr Macintosh explained at the hearing, the software used for modeling takes the topography as an assumption and then, by the application of mathematical formulae, calculates the way water will flow over that topography. This is what Dr Jordan did.
91. He was aware, from the detail on the surveys before him, that the flooding caused a breach of about 400 metres in the western embankment. In any case, the modelling software would take it into account and did so. Dr Macintosh had access to the computer files that Dr Jordan used and has seen that indeed the length of the breach that Dr Jordan's modeling took into account was of the order of 400 metres.

92. However, criticism arose because of an expression Dr Jordan used in his report in describing the landscape after the flood. At page 6 of his report dated 16 September 2011 he said:⁶⁵

“The most apparent difference between the two terrain surveys is that there was a breach in the embankment between the quarry pit and Lockyer Creek, near the north western corner of the quarry pit. This breach was approximately 55 metres wide and 8 metres deep, as shown in Figure 3-1.”

93. Figure 3-1 showed a breach of about 50 metres in a section of the embankment 100 metres wide. However, the modeling files demonstrate that Dr Jordan, in running his models, did not fail to take into account the full extent of the 400 metre breach. It appears that what has happened is that he has used language to draw attention to the most significant part of the breach and, for that reason, referred to it as the “most apparent difference”, which it was.
94. I have observed that other experts since have also, when appropriate, emphasised that particular part of the total breach in the embankment. So, for example, Dr Macintosh referred in his report to the “main breach”,⁶⁶ and which is the same area as that which Dr Jordan describes as showing “the most apparent difference” before and after the flood.
95. In a similar way, Mr Starr referred to this feature as the “main breach” in various places in his report of 12 July 2015.⁶⁷
96. It can be seen, therefore, that it was natural for Dr Jordan to identify this particular feature, which was the focus of attention of all relevant experts, as “the most apparent difference” between the landscape before and after the flood. The words which he chose to use at this place in his report can easily, and perhaps most naturally, be read to mean that there was *only* a 50 metre breach. It was not what Dr Jordan meant, but all that means is that the language chosen for the report might have been improved. That does not justify criticism of Dr Jordan’s professional competence.
97. I should point out that when this Commission first engaged Dr Macintosh I expected that he would be able to furnish a completed report in four weeks or so. I was wrong about that because I did not understand the complexity of the task that I had given to him. The job took much longer than that and even required an extension of time to the span of the Commission. Dr Jordan had to produce his report in a very constrained time frame. His report addressing the hydraulic modeling of the flooding of Grantham, and the scenarios with and without the quarry, was formally requested on 4 August 2011 and was required by (and was delivered on) 12 September 2011. And, as the three experts who have given evidence to me have agreed, it was right in its conclusions.

Conclusion

98. These conclusions are consistent with and supported by all of the expert evidence. There is no evidence to the contrary. I note that Dr Macintosh and Dr Newton, who each provided a separate principal report, undertook their work and their modelling for their respective principal reports independent of each other, unaware of the conclusions or processes that the other had employed.⁶⁸
99. Only Dr Macintosh considered the effect of the railway embankment and his opinion was that it did not cause or materially alter or contribute to the flooding of Grantham.⁶⁹
100. Quarry or no quarry, railway line or no railway line, if there is ever another sudden dump of water in the upper catchment of the Lockyer Creek of the order of that which fell on 10 January 2011, the same thing will happen again.⁷⁰

- ¹ Exhibit 1, Bureau of Meteorology, *Southeast Queensland Floods – January 2011* [p1: para 2].
- ² Exhibit 3, Sinclair Knight Merz, *Lockyer Creek Flood Risk Management Study*, December 2014 [p22: para 4].
- ³ Exhibit 3, Sinclair Knight Merz, *Lockyer Creek Flood Risk Management Study*, December 2014 [p22: para 4].
- ⁴ Exhibit 3, Sinclair Knight Merz, *Lockyer Creek Flood Risk Management Study*, December 2014 [p24: para 1].
- ⁵ Exhibit 3, Sinclair Knight Merz, *Lockyer Creek Flood Risk Management Study*, December 2014 [p56: Table 8-1].
- ⁶ Exhibit 3, Sinclair Knight Merz, *Lockyer Creek Flood Risk Management Study*, December 2014 [p56: Table 8-1].
- ⁷ Data obtained for 143203B Lockyer Creek at Helidon No.2. from <https://www.dnrm.qld.gov.au/water/water-monitoring-and-data/portal>
- ⁸ Bureau of Meteorology – *Provision of Preliminary Meteorological and Hydrological Information: Background briefing for the Queensland Floods Commission of Inquiry*, February 2011 - (Exhibit 38 to Queensland Floods Commission of Inquiry)(p14: para 1: bullet 4)
- ⁹ Bureau of Meteorology – *Provision of Preliminary Meteorological and Hydrological Information: Background briefing for the Queensland Floods Commission of Inquiry*, February 2011 - (Exhibit 38 to Queensland Floods Commission of Inquiry)(p14: para 1: bullet 4)
- ¹⁰ Exhibit 19, Dr David Newton, *Impact of the Grantham Sand Quarry on the January 2011 Flood in Grantham*, 3 July 2005 [p33: Figure 4.1].
- ¹¹ Exhibit 3, Sinclair Knight Merz, *Lockyer Creek Flood Risk Management Study*, December 2014 [p24: para 1].
- ¹² Bureau of Meteorology – *Provision of Preliminary Meteorological and Hydrological Information: Background briefing for the Queensland Floods Commission of Commission*, February 2011 - (Exhibit 38 to Queensland Floods Commission of Commission)(p16: para 1: bullet 5)
- ¹³ Exhibit 304, Dr John Macintosh, *Expert Hydrology Report – 10 January 2011 Flood – Circumstances and Contributing Factors – Supplementary Material No. 2*, 3 September 2015 [p54: para 125].
- ¹⁴ Exhibit 3, Sinclair Knight Merz, *Lockyer Creek Flood Risk Management Study*, December 2014 [p21: para 5].
- ¹⁵ Data obtained from <https://www.dnrm.qld.gov.au/water/water-monitoring-and-data/portal>
- ¹⁶ Exhibit 34, Statement of Thomas Friend, 27 May 2015 [p3: para 9]; Transcript, 28 July 2015: Thomas Friend [p500: lines 28–31; p501: lines 13-16]; Exhibit 25, Statement of Jonathan Sippel, 1 July 2015 [p5-6: paras 28-30]; Transcript, 21 July 2015: Jonathan Sippel [p117: lines 8-15]; Exhibit 45, Statement of Patrick (John) Gallagher, 1 July 2015 [p3: para 10]; Exhibit 48, Statement of Tony McIntosh, 27 May 2015 [p3: para 12; p4:para 14]; Transcript, 28 July 2015: Tony McIntosh [p530: line 35 – p531: line 22]
- ¹⁷ Exhibit 225, Statement of Charmaine Mallon, 1 July 2015 [p5: para 16].
- ¹⁸ Transcript 23 July 2015 Ian Pinkerton [p284: lines 415-425]; Transcript 21 July 2015: Frances Arndt [p91: lines 1 – 45]; Exhibit 24, Statement of Ian Pinkerton, 1 July 2015 [p2: paras 6-7]; Exhibit 24, Statement of Ian Pinkerton, 30 January 2011 [p2: paras 6-9]; Exhibit 187, Statement of Janet Crust, 30 January 2011 [p3: para 17]; Exhibit 187, Statement of Janet Crust, 6 July 2015 [p2: para 11]; Exhibit 18, Statement of Troy Steffens, 1 July 2015 [p2: para 8].
- ¹⁹ Transcript, 22 July 2015: Helen Besley [p218: line 6 – p289: line 13]; Exhibit 29, Statement of Helen Besley, 2 July 2015 [p2: paras 16-19]; Exhibit 105, 000 call of Helen Besley.
- ²⁰ Transcript, 21 July 2015: Frances Arndt [p92: lines 39-44]; Exhibit 22, Statement of Frances Arndt, 29 January 2011 [p3: paras 11-15]; Exhibit 23, Statement of Frances Arndt, 1 July 2015 [p2: paras 4–7].
- ²¹ Exhibit 144, Dr John Macintosh, *Expert Hydrology Report – 10 January 2011 Flood – Circumstances and Contributing Factors*, 11 August 2015 [p22: para 10].
- ²² Exhibit 27, Statement of Frank King, 1 July 2015 [p2: para 7- p3: para 12; Attachment KTK-1]
- ²³ Exhibit 68, Written material provided by Robert Ward (channel 9 Chief Pilot) and channel 9 helicopter footage; Exhibit 69, channel 9 helicopter footage.
- ²⁴ Exhibit 144, Dr John Macintosh, *Expert Hydrology Report – 10 January 2011 Flood – Circumstances and Contributing Factors*, 11 August 2015 [p45: para 114].
- ²⁵ Transcript, 20 August 2015: Mr Stefan Szykarski [p1355: line 43; p1356: line 2].
- ²⁶ Exhibit 144, Dr John Macintosh, *Expert Hydrology Report – 10 January 2011 Flood – Circumstances and Contributing Factors*, 11 August 2015 [p135: para 419].
- ²⁷ Transcript, 20 August 2015: Mr Stefan Szykarski [p1383: lines 30-42; p1384: line 4].
- ²⁸ Exhibit 142, Grantley Smith, *Expert Opinion: Stability of People, Vehicles and Buildings in Flood Water*, 13 August 2015.
- ²⁹ Transcript, 17 August 2015: Mr Grantley Smith [p1079: lines 6-9].
- ³⁰ Exhibit 142, Grantley Smith, *Expert Opinion: Stability of People, Vehicles and Buildings in Flood Water*, 13 August 2015 [p8-10: Section 5].
- ³¹ Exhibit 48, USB containing photograph taken at 3.15 pm on 10 January 2011 [img_228]; Exhibit 144, Dr John Macintosh, *Expert Hydrology Report – 10 January 2011 Flood – Circumstances and Contributing Factors*, 11 August 2015 [p173: para 498]; Transcript, 21 July 2015: Jonathan Sippel [p121: line 33 – p122: line 17].
- ³² Exhibit 144, Dr John Macintosh, *Expert Hydrology Report – 10 January 2011 Flood – Circumstances and Contributing Factors*, 11 August 2015 [p77: para 260].
- ³³ Exhibit 144, Dr John Macintosh, *Expert Hydrology Report – 10 January 2011 Flood – Circumstances and Contributing Factors*, 11 August 2015 [p33: para 64]; Exhibit 144, Dr John Macintosh, *Expert Hydrology Report – 10 January 2011 Flood – Circumstances and Contributing Factors – Supplementary Material No. 1*, 17 August 2015 [p30: Figure 1.33].
- ³⁴ Exhibit 144, Dr John Macintosh, *Expert Hydrology Report – 10 January 2011 Flood – Circumstances and Contributing Factors*, 11 August 2015 [p77: para 260].
- ³⁵ Exhibit 144, Dr John Macintosh, *Expert Hydrology Report – 10 January 2011 Flood – Circumstances and Contributing Factors*, 11 August 2015 [p66: para 204].

- ³⁶ Exhibit 144, Dr John Macintosh, *Expert Hydrology Report – 10 January 2011 Flood – Circumstances and Contributing Factors*, 11 August 2015 [p68: para 208].
- ³⁷ Exhibit 144, Dr John Macintosh, *Expert Hydrology Report – 10 January 2011 Flood – Circumstances and Contributing Factors*, 11 August 2015 [p26-27: para 29; p100: paras 342-350]
- ³⁸ Exhibit 144, Dr John Macintosh, *Expert Hydrology Report – 10 January 2011 Flood – Circumstances and Contributing Factors*, 11 August 2015 [p106: para 353].
- ³⁹ Exhibit 144, Dr John Macintosh, *Expert Hydrology Report – 10 January 2011 Flood – Circumstances and Contributing Factors*, 11 August 2015 [p106: para 353].
- ⁴⁰ Exhibit 144, Dr John Macintosh, *Expert Hydrology Report – 10 January 2011 Flood – Circumstances and Contributing Factors*, 11 August 2015 [p73: para 229].
- ⁴¹ Exhibit 144, Dr John Macintosh, *Expert Hydrology Report – 10 January 2011 Flood – Circumstances and Contributing Factors*, 11 August 2015 [p73: para 230]; Transcript, 17 August 2015: Dr John Macintosh [p1130: lines 3-5].
- ⁴² Transcript, 17 August 2015: Dr John Macintosh [p1132: lines 38-41]; Exhibit 144, Dr John Macintosh, *Expert Hydrology Report – 10 January 2011 Flood – Circumstances and Contributing Factors*, 11 August 2015 [p109].
- ⁴³ Transcript, 17 August 2015: Dr John Macintosh [p1149: lines 14-24].
- ⁴⁴ Transcript, 17 August 2015: Dr John Macintosh [p1132: lines 38-41].
- ⁴⁵ Exhibit 144, Dr John Macintosh, *Expert Hydrology Report – 10 January 2011 Flood – Circumstances and Contributing Factors*, 11 August 2015 [p97: para 336].
- ⁴⁶ Transcript, 20 August 2015: Dr John Macintosh [p1338: line 37 – p1340: line 21].
- ⁴⁷ Transcript, 20 August 2015: Dr John Macintosh [p1332: lines 25-32].
- ⁴⁸ Exhibit 304, Dr John Macintosh, *Expert Hydrology Report – 10 January 2011 Flood – Circumstances and Contributing Factors – Supplementary Material No. 2*, 3 September 2015 [p24: para 24].
- ⁴⁹ Exhibit 19, Dr David Newton, *Impact of the Grantham Sand Quarry on the January 2011 Flood in Grantham*, 3 July 2005 [p66-68].
- ⁵⁰ Exhibit 163, Mr Stefan Szykarski, *Review of Expert Hydrology Report – 10 January 2011 Grantham Flood*, 13 August 2015 [p10-11: para 55].
- ⁵¹ Exhibit 142, Grantley Smith, *Expert Opinion: Stability of People, Vehicles and Buildings in Flood Water*, 13 August 2015 [p8: para 5].
- ⁵² Exhibit 144, Dr John Macintosh, *Expert Hydrology Report – 10 January 2011 Flood – Circumstances and Contributing Factors*, 11 August 2015 [p35: para 72].
- ⁵³ Transcript, 24 July 2015: Martin Warburton [p391: lines 27-39].
- ⁵⁴ Transcript, 21 July 2015 : Lance Richardson [p171: lines 16-27].
- ⁵⁵ Exhibit 304, Dr John Macintosh, *Expert Hydrology Report – 10 January 2011 Flood – Circumstances and Contributing Factors – Supplementary Material No. 2*, 3 September 2015 [p36: Figure 5.5]. A gigalitre is 1,000,000,000 litres.
- ⁵⁶ Exhibit 304, Dr John Macintosh, *Expert Hydrology Report – 10 January 2011 Flood – Circumstances and Contributing Factors – Supplementary Material No. 2*, 3 September 2015 [p37: para 48].
- ⁵⁷ Exhibit 163, Mr Stefan Szykarski, *Review of Expert Hydrology Report – 10 January 2011 Grantham Flood*, 13 August 2015 [p10-11: para 55].
- ⁵⁸ Exhibit 142, Grantley Smith, *Expert Opinion: Stability of People, Vehicles and Buildings in Flood Water*, 13 August 2015 [p6: Figure 3].
- ⁵⁹ Exhibit 246, Statement of Annaka Sippel, 1 July 15 [p6: para 40].
- ⁶⁰ Exhibit 246, Statement of Annaka Sippel, 6 Feb 11 [p6: para 35].
- ⁶¹ Transcript, 28 July 2015: John (Sean) Gillespie [p537: line 7 – p538: line 4].
- ⁶² Exhibit 142, Grantley Smith, *Expert Opinion: Stability of People, Vehicles and Buildings in Flood Water*, 13 August 2015 [p9: Section 5.3].
- ⁶³ Exhibit 142, Grantley Smith, *Expert Opinion: Stability of People, Vehicles and Buildings in Flood Water*, 13 August 2015 [p10: Section 5.5].
- ⁶⁴ Dr Phillip Jordan, SKM, *Provision of Hydrological Advice to Queensland Floods Commission of Inquiry: Assessment of Impact of Quarrying Operations on Flash Flooding in Grantham on 10 January 2011*, 16 September 2011 [Exhibit 600 to the Queensland Floods Commission of Inquiry].
- ⁶⁵ Dr Phillip Jordan, SKM, *Provision of Hydrological Advice to Queensland Floods Commission of Inquiry: Assessment of Impact of Quarrying Operations on Flash Flooding in Grantham on 10 January 2011*, 16 September 2011 [Exhibit 600 to the Queensland Floods Commission of Inquiry][page 6: para 2].
- ⁶⁶ Exhibit 144, Dr John Macintosh, *Expert Hydrology Report – 10 January 2011 Flood – Circumstances and Contributing Factors*, 11 August 2015 [p26: para 26].
- ⁶⁷ Exhibit 131, Mr David Starr, *Grantham Quarry – Geotechnical Investigations & Expert Opinion on Formation of Earthworks*, 28 July 2015 [p2: para 11].
- ⁶⁸ Transcript, 19 August 2015: Dr John Macintosh [p1265: line 43 – p1266: line 1].
- ⁶⁹ Transcript, 17 August 2015: Dr John Macintosh [p1172: line 26 – p1173: line 20]; Exhibit 304, Dr John Macintosh, *Expert Hydrology Report – 10 January 2011 Flood – Circumstances and Contributing Factors – Supplementary Material No. 2*, 3 September 2015 [p2: para 28-p34: para 41].
- ⁷⁰ Transcript, 17 August 2015: Dr John Macintosh [p1175: lines 1-15].

Chapter 6: The initial investigation and how eyewitness accounts were dealt with

1. Term of Reference (e) requires me to consider how the initial investigation of the matters set out in Terms of Reference (a) to (d), and how eyewitness accounts of the flooding of the Lockyer Creek between Helidon and Grantham on 10 January 2011, were dealt with.
2. This Term of Reference does not, however, include a review or investigation of the way in which the Queensland Floods Commission of Inquiry (QFCOI) was conducted. Nor does it include a general consideration of the conduct by State Government agencies and Emergency Services in relation to the flooding or its aftermath, unless that conduct forms part of the initial investigation of the matters set out in Terms of Reference (a) to (d), or dealings with eyewitness accounts in relation to those matters.

Establishment of Taskforce Galaxy and scope of the investigation

3. The initial investigation of the flooding at Grantham on 10 January 2011 was undertaken by a specially formed Queensland Police Service task force known as Taskforce Galaxy. Taskforce Galaxy commenced its investigations on 12 January 2011 at the request and under the direction of the then State Coroner Michael Barnes. By 14 January 2011 Taskforce Galaxy had established an independent investigative response, running parallel with the incident command responsible for the immediate response and recovery efforts.¹
4. Taskforce Galaxy was initially tasked with gathering all evidence into the loss of life during the flood event and to report to the State Coroner. However, upon establishment of the QFCOI on 17 January 2011, Taskforce Galaxy's investigation was narrowed on 27 January 2011² to the investigation of loss of life through flooding and the immediate cause of death, and was not to include the cause of the flooding.
5. This is because section 4A of the *Commissions of Inquiry Act 1950* precludes investigation or inquiry by a coroner where the same matter is to be investigated or inquired into by a commission of inquiry constituted by a Supreme Court judge.
6. Given Taskforce Galaxy did not investigate the cause of the flooding, it did not, and rightly so, investigate those issues which fall within Terms of Reference (a) to (d). That is, it did not investigate issues relating to: any natural or man-made feature which could have altered or contributed to the flooding; whether the existence or breach of the Grantham quarry could have caused or contributed to the flooding of Grantham, or had a material impact on the damage caused by the flooding at Grantham; and whether the breach of the Grantham quarry had implications for evacuation of Grantham.
7. Accordingly, the witness statements taken by Taskforce Galaxy primarily dealt with eyewitnesses' experiences of the flooding at Grantham on 10 January 2011, and did not deal with issues relating to the contribution or impact of the Grantham quarry on the flooding of Grantham, or whether its breach had implications for the evacuation of Grantham.
8. It was suggested during the course of hearings, and in closing submissions from some parties, that the Terms of Reference for the QFCOI may not have extended to considering broader issues of "causation" and, therefore, the decision of the State Coroner to limit the scope of the investigation by Taskforce Galaxy might have been in error.³ I do not agree that the State Coroner was in error.

9. The Terms of Reference of the QFCOI required that Commission to consider, among other things, “the preparation and planning by federal, state and local governments; emergency services and the community for the 2010/2011 floods in Queensland”, “all aspects of the response to the 2010/2011 flood events” and the “adequacy of forecasts and early warning systems particularly as they related to the flooding events in Toowoomba, and the Lockyer and Brisbane Valleys”. The State Coroner’s view was that these Terms of Reference fully captured the making of preventative recommendations and therefore he “was not to look at matters of prevention”.⁴ He was plainly correct about this. Making findings as to matters of prevention necessarily required making antecedent findings as to what was to be prevented and therefore the cause of what occurred, which the State Coroner implicitly recognised.⁵ The State Coroner was correct to take the view, which he discussed with the Commissioner for the QFCOI, that these were matters to be investigated or inquired into by the QFCOI and he was therefore prevented from considering them.
10. There are good reasons why the coroner is prevented from investigating or inquiring into the same matter that is to be investigated by a commission of inquiry constituted by a sitting Supreme Court judge. These include preventing the duplication of significant effort and resources, as well as ensuring the finality of findings by such a commission.

Taskforce Galaxy’s investigation

11. Management of Taskforce Galaxy and the investigation that followed was very similar to a typical Queensland Police Service investigation. A hierarchical structure to facilitate management of Taskforce Galaxy was quickly put in place and key witnesses identified so that witness statements about the flood event could be formally taken.
12. Taskforce Galaxy itself was comprised of Queensland Police Service members from the Southern Region and the Homicide Investigation Group. Detective Superintendent John Sheppard was the overall Taskforce Commander. Detective Inspectors Andrew Massingham and David Isherwood were responsible for joint management of the Taskforce and were assisted by two lead investigators; Detective Senior Sergeants Paul McCusker and Mitchell Castles.⁶
13. The investigators were responsible for examining witness statements, collating and examining imagery, analysing and interpreting telecommunications data, the emergency response, autopsy findings and issues which affected or impacted the death of the person the subject of the investigation.⁷
14. The initial focus of Taskforce Galaxy was to debrief evacuees and emergency services staff to identify those people who had information directly relevant to the loss of life in Grantham. Police investigators within Taskforce Galaxy identified, located and interviewed potential witnesses who were temporarily living in evacuation centres at Gatton, Grantham, Helidon and Murphys Creek.⁸ A formal questionnaire was also developed in consultation with the State Coroner to help to find potential witnesses. Overall, Taskforce Galaxy received 241 replies to the questionnaire.⁹ Completed questionnaires were then used to identify witnesses to events and avenues of investigation. Those witnesses were interviewed over the following days, with further witnesses identified through this process interviewed over subsequent weeks.¹⁰ In some instances photographic and video imagery was recovered, and video recorded re-enactments were obtained from witnesses.

The handling of evidence by Taskforce Galaxy

15. During interviews with Commission staff some Grantham residents raised concerns that some witness statements taken by Taskforce Galaxy in 2011 were either not passed on to the QFCOI or to the State Coroner, or went missing completely.

16. A total of 854 statements were taken by the Queensland Police Service as part of Taskforce Galaxy investigations. Not all of these formed part of the coronial brief of evidence due to the subsequent narrowed scope of Taskforce Galaxy's investigation as a result of the establishment of the QFCOI. Taskforce Galaxy's lead investigators, Detective Senior Sergeants McCusker and Castles, decided what material was to be included in the coronial brief of evidence, and only chose material directly relevant to each loss of life event. This meant that in total, 365 witness statements were ultimately passed on to the State Coroner.¹¹
17. Those witness statements tendered as part of the QFCOI's consideration of relevant evidence are publicly available on that Commission's website. The entire Taskforce Galaxy coronial investigation was made available to the Commission as part of its investigations, and all of the material relevant to the Commission's Terms of Reference was ultimately tendered as evidence.¹²
18. In no case has this Commission been able to identify the loss of a witness statement taken by Taskforce Galaxy in 2011. A large number of these statements have been tendered as part of the evidence presented to this Commission and are publicly available on the Commission's website.
19. Issues were also raised during the course of the Commission about video footage provided to Taskforce Galaxy which had allegedly gone missing. Specifically, video footage taken by Ms Tracey Anne Smith of the flooding at Grantham on 10 January 2011 was missing.¹³
20. In evidence provided to the Commission, it has been established that Ms Smith handed the video footage in question to Mr Shane Brennan, a counsellor from Queensland Health, on 16 January 2011. Ms Smith asked Mr Brennan to pass the video footage on to the Queensland Police Service for safe keeping and for it to be used in any future investigation into the flood event.¹⁴ Mr Brennan passed the video footage on to Senior Constable Debbie Haworth in the Police Forward Command Post at Grantham on 16 January 2011 and told Senior Constable Haworth that the video contained footage of the flood event.¹⁵ At the time, Mr Brennan did not record the name of the police officer he handed it to and was not provided with an exhibit receipt.¹⁶
21. Senior Constable Haworth placed the video footage into a drawer and entered it into a running log. Later that day, Senior Constable Haworth handed the video footage to Constable Hayley Munro and provided details of the owner of the video footage, and of Mr Brennan, to her. Constable Munro recalls working in the Police Forward Command Post at Grantham on 16 January 2011 and that as part of her role that day, she was handed lost property to place in containers to be transported to Toowoomba to be lodged as found property.¹⁷ She does not recall being given a video tape or any conversation with Senior Constable Haworth about the video tape.¹⁸ She said in oral evidence, and I accept, that had she been given a video recording and been told that it was evidence, she would have treated it accordingly. She was a new police officer at the time and would have regarded being entrusted with evidence as a serious and significant matter. The video tape has never been recovered.
22. The handling of evidence from 10 January 2011, including the video footage in question, must be considered in the broader context of the events of that day. The scale and devastation of the flooding experienced in the Lockyer Valley was like nothing that region, or the State of Queensland for that matter, had experienced before. In this instance, video footage which should have been registered as an exhibit was handed to a police officer who, on that day, was responsible for the handling of lost property and it was therefore lodged as such. This was unfortunate but it did not have any effect on Taskforce Galaxy's overall investigation of the flood event. In fact, Taskforce Galaxy did an exceptional job of collecting, using and storing a substantial amount of imagery relating to the flood event, which included photographs and video files, and amounted to 95 gigabytes of imagery collected from witnesses, government agencies and media outlets.¹⁹
23. This included putting in place a strategy to handle imagery, including encouraging witnesses to come forward and supply their imagery to Taskforce Galaxy. As imagery was collected, it was stored on the Taskforce Galaxy server

and a dedicated Mapping and Imagery Cell was responsible for reviewing all imagery collected.²⁰ An electronic package of relevant evidence and imagery was uploaded onto a portable hard drive which was ultimately provided to the State Coroner.²¹ The State Coroner provided a copy of this material to the Commission.²²

24. I have not found any other evidence, including photographs and video footage that was misplaced during the course of Taskforce Galaxy's investigation. Overall, I am satisfied that Taskforce Galaxy appropriately handled all evidence in its possession.

The exclusion zone at Grantham

25. In order to conduct searches for missing persons and ensure the safety of the public, the Queensland Police Service limited access to Grantham to all persons, other than emergency response, search and recovery personnel, from 12 January to 18 January 2011.²³ Prior to that, police arranged for some residents to be accompanied to collect personal items including medication. Government and support resources had controlled access to Grantham. Grantham residents were permitted to re-enter the town on 18 January 2011, and full access was permitted after a community meeting on 7 February 2011.²⁴
26. The then Premier, the Honourable Anna Bligh MP, made a "Declaration of a Disaster Situation – State Level" on 11 January 2011 at 10:12 am. The declaration was maintained until midnight on 25 January 2011.²⁵ Following the declaration, the powers for exclusion under section 77 of the *Disaster Management Act 2003* applied.
27. Under section 69 of the *Disaster Management Act 2003*, the Minister and the Premier may declare a disaster situation for the State if satisfied that a disaster has happened, is happening or is likely to happen in Queensland, and if it is necessary for the district disaster coordinator or a declared disaster officer to exercise declared disaster powers to prevent or minimise any of the following: loss of human life, illness or injury to humans, property damage or loss, or damage to the environment.
28. In his statement to the Commission dated 30 June 2015,²⁶ the Mayor of the Lockyer Valley Regional Council, Mr Stephen Jones, raised concerns about the location of the exclusion zone and duration of the closure of Grantham township. In summary, Mr Jones stated he did not understand why the entrance checkpoint to the west of Grantham was located so far west, that is, past Quarry Access Road at Grantham. He questioned the need to extend the exclusion zone so far west given the police did not close other communities that, in his view, were far more heavily impacted than the homes around the quarry.²⁷
29. The exclusion zone itself covered approximately seven square kilometres of the Grantham township, and was maintained by a cordon of roadblocks, as well as geographical boundaries such as creeks and railway lines. Police checkpoints were located at roads, which was the easiest way to prevent people from entering Grantham, and positioned where people could safely turn their vehicles around.²⁸
30. In summary, the perimeter of the exclusion zone to the south of Grantham, was on Harris Street/Grantham Winwill Road at the intersection with Lockyer Creek and Thistlethwaite Bridge. To the east, officers were placed at the intersection of Gatton-Helidon Road and Old Toowoomba Road (at the crest of the hill heading out of Grantham toward Gatton). To the north, officers were placed at the Railway Bridge underpass on William Street at the intersection of Lawlers Road and Victor Street. To the west, officers were placed on Gatton-Helidon Road just to the east of the railway underpass, and to the west of Quarry Access Road in the vicinity of the property at 1703 Gatton-Helidon Road.²⁹ A map of the Grantham exclusion area is at Figure 6.1 below.

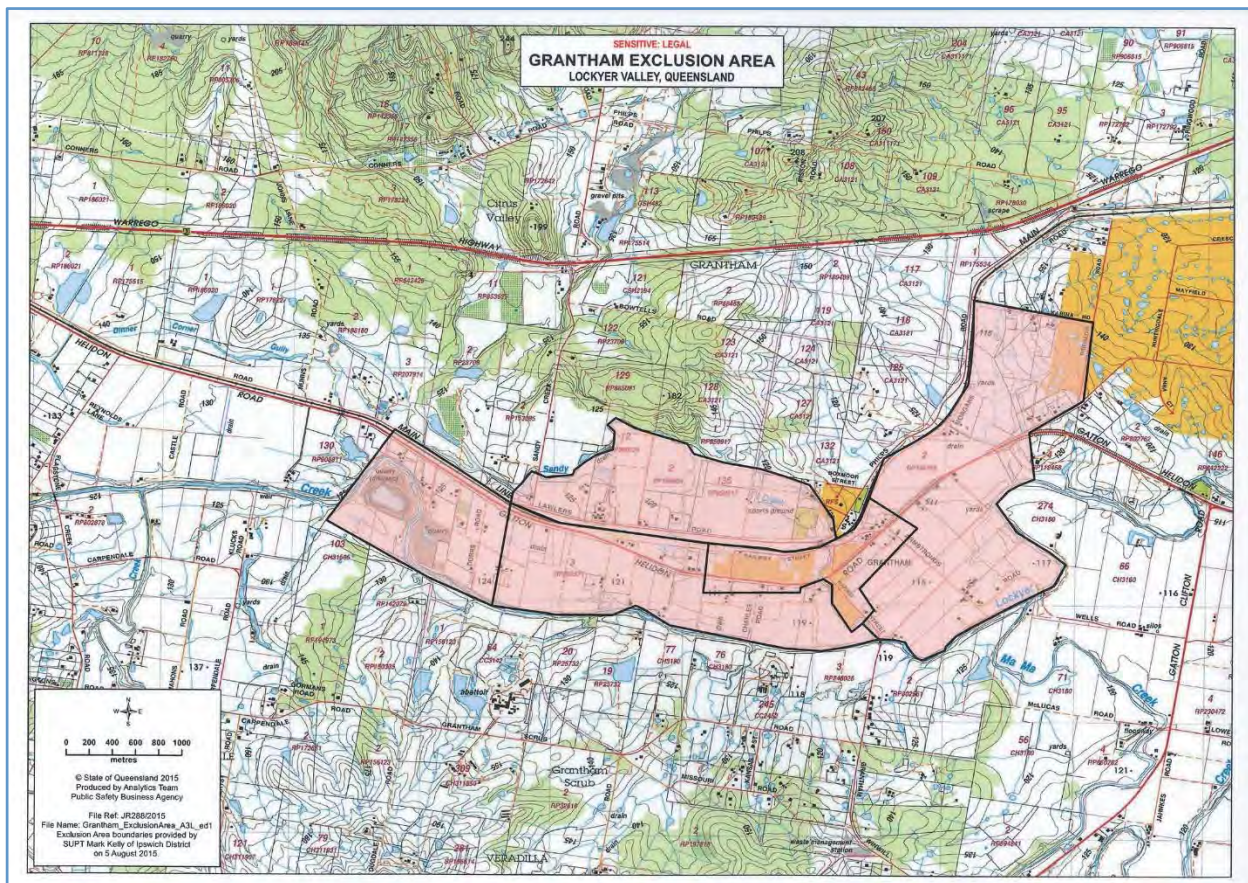

Figure 6.1: Map of the Grantham exclusion area following the 10 January 2011 flood.

Source: Exhibit 134, Map of Grantham exclusion area.

31. In his oral evidence at the Commission hearings on 5 August 2015, Mr Jones stated that having read a number of relevant statements, he accepts the soundness of the response from authorities about the closure of Grantham and the reasons for the size and perimeter of the exclusion zone, and that it was “the right thing to do”.³⁰
32. Both the local State Member, Mr Ian Rickuss MP, and Mr Lance Richardson also raised concerns about the closure of Grantham, referring to police heavy handedness in the way that Grantham was locked down (that is, that Grantham was locked down for a period causing extreme water and flood damage), and stating that it caused frustration amongst Grantham residents.³¹ Mr Rickuss’ assertions of police heavy handedness were also referred to by Mr Jones in his statement of 30 June 2015.³²
33. All persons, including Grantham residents, were excluded from the town for a number of reasons, including significant risk to personal safety (for example from unsafe electrical wires and instruments, unsafe buildings and possible exposure to chemicals and asbestos), and to ensure the safety and security of property (for example, from theft) during the search. Importantly, the Queensland Police Service was also undertaking its search for missing persons, which included a small child. This required systematic and repeated searches of houses, outbuildings, land and water.
34. While a mass casualty search of this kind does not have set procedures, the Queensland Police Services’ existing search protocols were applied and individual decisions were made about the application of other search techniques, such as the use of heavy machinery to assist with the search.³³

35. Based on the evidence, it appears to me that the investigation undertaken by the Queensland Police Service, including Taskforce Galaxy, was conducted in an organised, systematic, professional and efficient manner. The investigation was similar to other coronial investigations which utilised a range of existing processes and protocols including those powers which applied under the *Disaster Management Act 2003*. The Queensland Police Service relied on existing and reliable methods of collecting, collating and analysing relevant evidence, including witness statements, expert evidence, photographs and video footage.
36. Understandably, and perhaps inevitably, some Grantham residents were upset and frustrated by the fact that they were excluded from the town and their homes for six days. However, there was a need to close Grantham in order to ensure both the safety of people and property, and most importantly, to search for missing persons. Indeed, the length of time of exclusion was heavily affected by the search for missing persons with the last body recovered on 17 January 2011; the day before Grantham was reopened to residents.³⁴
37. Given the scale of the disaster, including considerable damage to land and buildings, and bearing in mind the number of people that were missing, the investigation and search were both conducted as systematically, quickly and sensitively as possible.

Ability of Mr Daniel McGuire to contact friends, relatives or the media immediately after 10 January 2011

38. When Mr McGuire initially gave evidence, he believed he had been prevented by the then Queensland Fire and Rescue Service from contacting friends or relatives, or the media in the weeks after the 10 January 2011 flood event and that, as a result, it was some time before his relatives were informed of what had happened to him and his family. Mr McGuire thought this might have occurred because, in the day or so before the 10 January 2011 flood event, he suggested to his superiors in the Rural Fire Service that Grantham should be evacuated.³⁵
39. However, Mr McGuire has considered the matter further and has realised he was mistaken in his recollection.³⁶ His confusion was entirely understandable given what occurred to him and his family. Mr Stuart Damrow,³⁷ who stayed with Mr McGuire at a hotel in Toowoomba immediately after the flood, has confirmed there were no restrictions on Mr McGuire's movements or who visited him or spoke to him on the telephone. Mr Stanley Jibson, Mr McGuire's father, recalls that he was advised on 11 January 2011 about what had happened to Mr McGuire and his family³⁸ and visited Mr McGuire a few days later. Ms Gwendolene Drury, Mr Jibson's step-sister, visited Mr McGuire in his hotel on 11 and 13 January 2011 following a telephone call from Mr McGuire's father on the morning of 11 January 2011.³⁹

Treatment of Grantham residents by Queensland Police Service officers

40. Some Grantham residents raised concerns about the manner in which they were treated by Queensland Police Service officers during the course of the response and recovery efforts and Taskforce Galaxy investigation. These concerns primarily relate to a perceived lack of respect and feeling ignored, distrusted, patronised and doubted.⁴⁰ Further, some Grantham residents, as well as the Mayor of the Lockyer Valley Regional Council, Mr Stephen Jones, stated there was a lack of communication and information passed on to the community⁴¹ and a need for more open communication processes.⁴² Mr Jones highlighted this issue in the context of what he saw as a lack of communication around the reopening of Grantham to residents on 18 January 2011.⁴³
41. Both Ms Lisa Spierling and Ms Sharon Watkins described feeling that their recollection or experience of the flood events was doubted by the authorities.⁴⁴ Ms Spierling's evidence largely relates to the fact her submissions to the QFCOI about the timing of State Emergency Service warnings in Grantham were discounted in favour of evidence provided by relevant State Emergency Service officers.⁴⁵ This issue is outside the Commission's Terms of Reference

but further information is provided in Appendix E. Ms Watkins' concerns were about the way in which she was interviewed by police officers when giving a statement in 2011; that the surroundings (a police station) made her uncomfortable and the process of questioning made her feel her recollection was being doubted. Mr Raymond Van Dijk stated that when he gave a statement to police in 2011, he had the impression the police officer was not interested in his version of events when it became clear he had only suffered property loss. Mr Warburton's concerns were broader, that while those providing the services were doing their best, he felt their superiors did not listen to residents' accounts and did not value local knowledge and direct experience of the flood.

42. Given the scale of the disaster, the number of people involved (both residents affected by the floods and police and emergency response staff) and the nature of the issues those people were dealing with, it is inevitable there would be individual instances where people felt they were not treated with respect or were not being listened to or, at least, that there would be good reason to think so. It is not possible to know for certain whether the perceptions of Grantham residents that their accounts were not believed or not valued reflected the views of those in authority. If it was the case then it is disappointing. Even if it was not the case, there are no doubt lessons to be learned about dealing with eyewitnesses who have been through a disaster.
43. With regard to concerns that there was a lack of communication with the community, it is important to note the Queensland Police Service implemented a number of strategies to provide information. Taskforce Galaxy established a drop-in centre at the Gatton Community Centre (staffed by Taskforce Galaxy personnel) where witnesses and others affected by the flood could attend to both provide statements and speak to police about issues of concern.⁴⁶ A Family Liaison Cell, comprising two police officers, was established to liaise with families of the deceased to keep them informed about the investigation. These officers were contactable by those families on a 24/7 basis.⁴⁷
44. Two community liaison officers were appointed at Gatton and Helidon to act as communication points between the community and the ongoing search and rescue operation, including to provide information to the community about the investigation.⁴⁸ These officers were appointed by Deputy Commissioner Gollschewski in response to negativity towards police, and as it had become clear that the community was not aware of the reasons behind certain decisions made by police, including the decision to close Grantham.⁴⁹ Both Deputy Commissioner Gollschewski and Inspector Benjamin Marcus (Grantham's Community Liaison Officer) considered this greatly assisted the recovery of the community.⁵⁰ In his evidence Mr Warburton specifically praised the work of Inspector Marcus in answering the community's questions, and for showing empathy and understanding to the community.⁵¹
45. To further improve communication with the Grantham community, regular briefings were provided to the community by the Police Forward Commander and other senior Queensland Police Service officers including Deputy Commissioner Gollschewski, and then Deputy Commissioner Ian Stewart and Commissioner Robert Atkinson.⁵²
46. As Grantham's Community Liaison Officer, Inspector Marcus held twice daily briefings with the community which were generally attended by 50 to 100 residents at a time. These briefings offered an opportunity for Inspector Marcus to provide information about the search and rescue operation and for the community to be involved in decision making processes such as how to engage with the media.⁵³
47. In his oral evidence to the Commission on 6 August 2015, Mr Jones raised concerns about the way the reopening of Grantham was handled. Specifically he perceived a lack of communication with him and the Lockyer Valley Regional Council about when the re-entry would occur and the impact that had on the Lockyer Valley Regional Council's ability to help prepare residents for the return.⁵⁴ Deputy Commissioner Gollschewski said that efforts were made to contact Mr Jones via telephone to inform him of the meeting on 18 January 2011 but that his phone was not answered.⁵⁵

48. Consultation on the reopening of Grantham occurred with the Lockyer Valley Disaster Management Group on 17 January 2011 and continued into 18 January 2011. The decision to reopen Grantham was formally made by Deputy Commissioner Gollschewski on the evening of 17 January 2011. A meeting was then held on 18 January 2011 at the Grantham School Recovery Centre to update and advise the community about the re-entry process for the town. Community meetings to explain the issues of search and exclusion directly to the community were also held at both Grantham and Helidon on 16 January 2011.⁵⁶
49. It was unfortunate that Mr Jones was only told of the 18 January 2011 meeting on the morning it was held. He was clearly concerned about ensuring that Grantham residents were appropriately supported in their return to the town. He was, after all, the Mayor. However, given the level of ongoing communication by police with the Grantham community about the search and rescue operation, including the closure and reopening of the town, it appears that every effort was made to keep the community appropriately informed even if, in some instances, such as this one, those efforts did not succeed.

¹ Exhibit 242, Statement of Detective Superintendent John Sheppard, 7 July 2011 [p2-3]; Exhibit 80, Affidavit of Detective Inspector David Isherwood, 17 June 2015 [p3: para 8 - p4: para 14].

² Exhibit 80, Affidavit of Detective Inspector David Isherwood, 17 June 2015 [p8: para 30 - p9: para 33].

³ Transcript, 4 August 2015: Detective Inspector David Isherwood [p792: line 32 – p793: line 11]; Written closing submission on behalf of the Grantham Families, 2 September 2015 [p9: para 44 – p:11 para 59]; Written closing submission of the State of Queensland, 28 August 2015 [p18: para 54].

⁴ Coronial Inquest: Office of the State Coroner, *Inquest into the deaths caused by the south-east Queensland floods of January 2011*, 5 June 2012, p4.

⁵ Coronial Inquest: Office of the State Coroner, *Inquest into the deaths caused by the south-east Queensland floods of January 2011*, 5 June 2012, p4.

⁶ Transcript, 4 August 2015: Detective Inspector David Isherwood [p757: lines 39-41].

⁷ Exhibit 76, Statement of Detective Senior Sergeant Paul McCusker, 14 July 2011 [p2].

⁸ Exhibit 77, Statement of Detective Senior Sergeant Mitchell Castles, 12 July 2011 [p1: para 4].

⁹ Transcript, 4 August 2015: Detective Inspector David Isherwood [p770, line 42].

¹⁰ Exhibit 242, Statement of Detective Superintendent John Sheppard, 7 July 2011 [p3-4].

¹¹ Exhibit 80, Affidavit of Detective Inspector David Isherwood, 17 June 2015 [p10: para 40].

¹² Exhibit 305, Taskforce Galaxy Coronial Package.

¹³ Exhibit 96, Statement of Stephen Jones, 30 June 2015 [p5: para 20]; Transcript, 6 August 2015: Stephen Jones [p954: line 38]; Transcript, 7 August 2015: Lisa Spierling [p1067: lines 39-40].

¹⁴ Exhibit 180, Statement of Shane Brennan, 13 July 2015 [p2: para 7].

¹⁵ Exhibit 180, Statement of Shane Brennan, 13 July 2015 [p2: para 8]; Exhibit 86, Affidavit of Plain Clothes Senior Constable Debbie Haworth, 13 July 2015 [p2: para 8]; Transcript, 4 August 2015: Plain Clothes Senior Constable Debbie Haworth [p832: lines 10-17].

¹⁶ Exhibit 180, Statement of Shane Brennan, 13 July 2015 [p2: para 9].

¹⁷ Transcript, 4 August 2015: Plain Clothes Constable Hayley Munro [p826: lines 38-39; p827: lines 17-18].

¹⁸ Exhibit 88, Affidavit of Plain Clothes Constable Hayley Munro, 14 July 2015 [p2: paras 3-5].

¹⁹ Exhibit 78, Statement of Detective Sergeant Ian Mercer, 16 July 2011 [p1: para 4 - p2: para 6].

²⁰ Exhibit 78, Statement of Detective Sergeant Ian Mercer, 16 July 2011 [p1: para 4 - p2: para 12].

²¹ Exhibit 75, Affidavit of Andrew Massingham, 16 June 2015 [p3: para 14].

²² Exhibit 305, Taskforce Galaxy Coronial Package.

²³ Exhibit 89, Affidavit of Superintendent Mark Kelly, 10 July 2015 [p2: para 6 – p3: para 9].

²⁴ Exhibit 89, Affidavit of Superintendent Mark Kelly, 10 July 2015 [p2-3: para 9].

²⁵ Exhibit 89, Affidavit of Superintendent Mark Kelly, 10 July 2015 [p4: paras 13-15].

²⁶ Exhibit 96, Statement of Stephen Jones, 30 June 2015.

²⁷ Exhibit 96, Statement of Stephen Jones, 30 June 2015 [p3: para 13].

²⁸ Transcript, 4 August 2015: Mark Kelly [p833: lines 42-45].

²⁹ Exhibit 89, Affidavit of Superintendent Mark Kelly, 10 July 2015 [p2: para 7].

³⁰ Transcript, 5 August 2015: Stephen Jones [p927: lines 9-19].

³¹ Exhibit 128, Submission by Ian Rickuss to Queensland Floods Commission of Inquiry [p17]; Exhibit 26, Statement of Lance Richardson, 16 March 2011 [p3: para 11].

-
- ¹ Exhibit 242, Statement of Detective Superintendent John Sheppard, 7 July 2011 [p2-3]; Exhibit 80, Affidavit of Detective Inspector David Isherwood, 17 June 2015 [p3: para 8 - p4: para 14].
 - ² Exhibit 80, Affidavit of Detective Inspector David Isherwood, 17 June 2015 [p8: para 30 - p9: para 33].
 - ³ Transcript, 4 August 2015: Detective Inspector David Isherwood [p792: line 32 – p793: line 11]; Written closing submission on behalf of the Grantham Families, 2 September 2015 [p9: para 44 – p:11 para 59]; Written closing submission of the State of Queensland, 28 August 2015 [p18: para 54].
 - ⁴ Coronial Inquest: Office of the State Coroner, *Inquest into the deaths caused by the south-east Queensland floods of January 2011*, 5 June 2012, p4.
 - ⁵ Coronial Inquest: Office of the State Coroner, *Inquest into the deaths caused by the south-east Queensland floods of January 2011*, 5 June 2012, p4.
 - ⁶ Transcript, 4 August 2015: Detective Inspector David Isherwood [p757: lines 39-41].
 - ⁷ Exhibit 76, Statement of Detective Senior Sergeant Paul McCusker, 14 July 2011 [p2].
 - ⁸ Exhibit 77, Statement of Detective Senior Sergeant Mitchell Castles, 12 July 2011 [p1: para 4].
 - ⁹ Transcript, 4 August 2015: Detective Inspector David Isherwood [p770, line 42].
 - ¹⁰ Exhibit 242, Statement of Detective Superintendent John Sheppard, 7 July 2011 [p3-4].
 - ¹¹ Exhibit 80, Affidavit of Detective Inspector David Isherwood, 17 June 2015 [p10: para 40].
 - ¹² Exhibit 305, Taskforce Galaxy Coronial Package.
 - ¹³ Exhibit 96, Statement of Stephen Jones, 30 June 2015 [p5: para 20]; Transcript, 6 August 2015: Stephen Jones [p954: line 38]; Transcript, 7 August 2015: Lisa Spierling [p1067: lines 39-40].
 - ¹⁴ Exhibit 180, Statement of Shane Brennan, 13 July 2015 [p2: para 7].
 - ¹⁵ Exhibit 180, Statement of Shane Brennan, 13 July 2015 [p2: para 8]; Exhibit 86, Affidavit of Plain Clothes Senior Constable Debbie Haworth, 13 July 2015 [p2: para 8]; Transcript, 4 August 2015: Plain Clothes Senior Constable Debbie Haworth [p832: lines 10-17].
 - ¹⁶ Exhibit 180, Statement of Shane Brennan, 13 July 2015 [p2: para 9].
 - ¹⁷ Transcript, 4 August 2015: Plain Clothes Constable Hayley Munro [p826: lines 38-39; p827: lines 17-18].
 - ¹⁸ Exhibit 88, Affidavit of Plain Clothes Constable Hayley Munro, 14 July 2015 [p2: paras 3-5].
 - ¹⁹ Exhibit 78, Statement of Detective Sergeant Ian Mercer, 16 July 2011 [p1: para 4 - p2: para 6].
 - ²⁰ Exhibit 78, Statement of Detective Sergeant Ian Mercer, 16 July 2011 [p1: para 4 - p2: para 12].
 - ²¹ Exhibit 75, Affidavit of Andrew Massingham, 16 June 2015 [p3: para 14].
 - ²² Exhibit 305, Taskforce Galaxy Coronial Package.
 - ²³ Exhibit 89, Affidavit of Superintendent Mark Kelly, 10 July 2015 [p2: para 6 – p3: para 9].
 - ²⁴ Exhibit 89, Affidavit of Superintendent Mark Kelly, 10 July 2015 [p2-3: para 9].
 - ²⁵ Exhibit 89, Affidavit of Superintendent Mark Kelly, 10 July 2015 [p4: paras 13-15].
 - ²⁶ Exhibit 96, Statement of Stephen Jones, 30 June 2015.
 - ²⁷ Exhibit 96, Statement of Stephen Jones, 30 June 2015 [p3: para 13].
 - ²⁸ Transcript, 4 August 2015: Mark Kelly [p833: lines 42-45].
 - ²⁹ Exhibit 89, Affidavit of Superintendent Mark Kelly, 10 July 2015 [p2: para 7].
 - ³⁰ Transcript, 5 August 2015: Stephen Jones [p927: lines 9-19].
 - ³¹ Exhibit 128, Submission by Ian Rickuss to Queensland Floods Commission of Inquiry [p17]; Exhibit 26, Statement of Lance Richardson, 16 March 2011 [p3: para 11].

Chapter 7: A final consideration

1. This Commission of Inquiry was established principally to determine the causes of the destructive and fatal flood of 10 January 2011. I have presented my conclusions about the causes in this report. To arrive at these conclusions I had the benefit of the clear recollections of the people who were there on that day and who gave me information in great and accurate detail. That evidence was inevitably and necessarily the starting point of the investigation.
2. I was also enormously helped by the work of those who meticulously gathered and preserved data about the behaviour of the water. There were also many people who took photographs and videos of the flood as it happened and they then took the trouble to give these precious records to the Commission, some of which had never been seen before, so they could be studied to ensure that any conclusions I reached would be consistent with recorded fact.
3. The experts retained to provide technical opinions have been rigorous and meticulous in their effort to apply their learning and skill to find the answers. Dr Macintosh, in particular, apprehended from the first, indeed at the moment he was first approached to perform this work and even before he was formally retained, that what he was being asked to do was more than to apply his huge technical skills to a routine job. He grasped immediately that he was being asked to accept an undertaking that was really a public service and that this would require of him an all-embracing devotion in seeking out the truth of the matter for the benefit of the survivors of the flooding. What they had experienced in January 2011 and what they have continued to experience demanded an exhaustive study which could leave no room for reasonable doubts. In his pursuit of this objective he demanded, and received, adequate time to fulfil his brief – a brief that required far more detailed and meticulous analysis and calculation than any of us, perhaps even Dr Macintosh himself, had contemplated. The result was a report, supported by comprehensive and painstaking oral evidence, that has left no room at all for rational doubt that his conclusions were right.
4. The greatest contribution of all to this achievement, in my respectful opinion, has been that of the survivors of the flood who strived for four years to bring to pass an inquiry like this and who then themselves went on to furnish the indispensable primary information about what happened. Without this, there could have been nothing.
5. And it has been obvious to me that every one of them has suffered fresh anguish in the course of this long undertaking. In particular, I could see how hard it was for all of them to give evidence and to be forced to confront their dreadful memories.
6. I say all of this in order to stress one final consideration. It is that any person with the willingness to read and to consider this report carefully and, if necessary to study the evidence of the eyewitnesses and experts that backs it up, must conclude that the flood of 10 January 2011 was a natural disaster and that no human agency caused it or could ever have prevented it.
7. That is the heart of the matter and it cannot but affect the meaning and the significance that each person will now attribute to the loss and pain which the flood has brought. What that meaning and significance is for each survivor is an exceptionally personal matter – and, for some, it may take patience over a lifetime to reach.

Appendix A: Expert reports – geotechnical advice

1. The Commission engaged a geotechnical engineer, Mr David Starr, to provide his expert opinion regarding certain aspects of the Grantham sand plant.

Mr Starr's qualifications and experience

2. Mr Starr is a geotechnical engineer with 44 years' experience gained overseas and in Australia, the author of over 20 technical papers, and the Australian representative on the International Society of Soil Mechanics and Geotechnical Engineers committees on Forensic Engineering and on Professional Practice. Mr Starr's areas of expertise are in geotechnical investigations, geotechnical design, construction monitoring, engineering geology, rock properties and soft soil engineering.¹

Scope of work performed by Mr Starr

Starr main report

3. Initially, Mr Starr was engaged to:²
 - a) provide an opinion about whether the embankments surrounding the Grantham quarry were natural or man-made and, if a mixture of the two, the location and extent of each;
 - b) determine the likely natural pre-quarry ground surface; and
 - c) to the extent possible, provide an opinion on how and when any man-made parts of the embankments had been constructed.
4. Mr Starr produced a report to the Commission entitled *Grantham Quarry - Geotechnical investigations and expert opinion on formation of earthworks* on 28 July 2015 (the **Starr main report**).³ In conjunction with this report, Mr Starr also produced:
 - (a) a figure containing an enlarged cross-section of the western embankment to the Grantham quarry;⁴
 - (b) a figure containing Mr Starr's analysis of the materials removed and replaced at the Grantham quarry (including along the length of the western embankment) by the January 2011 floods (**Figure 9**);⁵ and
 - (c) digital animations containing (i) images of the western embankment in 1997 and in 2001, and (ii) images of the western embankment to the Grantham quarry in 2001 and in 2009.⁶
5. In addition, Mr Starr gave evidence at the Commission's hearings concerning the Starr main report on 6 August 2015 and was cross-examined at length concerning its findings.

Starr first supplementary report

6. Mr Starr was also engaged to provide an opinion on the proximity and the height of a broken utility power pole 182127 to the embankments surrounding the Grantham quarry⁷ and the height and angle of the embankments.

7. This was addressed by Mr Starr in his supplementary report entitled *Grantham Quarry – Geotechnical Investigations and expert opinion on formation of earthworks - supplementary report concerning location of failed power pole P182127* on 28 July 2015 8 (**Starr first supplementary report**).

Starr second supplementary report

8. Finally, Mr Starr was engaged to provide an opinion on the pre-quarry terrain in the south east portion of the Grantham sand plant (the plant area)⁹. Mr Starr produced a second supplementary report entitled *Grantham quarry - geotechnical investigations and expert opinion on formation of earthworks - supplementary report concerning pre-quarry terrain at sand batching plant* (**Starr second supplementary report**).¹⁰

Methodology used by Mr Starr to make his findings

9. Mr Starr examined available imagery from LiDAR surveys, aerial photography, satellite images as well as photographs and plans provided in witness statements and submissions to the Commission.
10. In addition, Mr Starr undertook two site inspections. At the second inspection, he supervised the digging of 25 test pits with an excavator to allow him to examine the properties of the soil at depths of up to three metres.

LiDAR surveys

11. LiDAR is a remote sensing method that uses pulses of light from a laser carried in an aeroplane to measure the distance from the laser to the earth surface. The light pulses – together with other data recorded by the airborne system - generate precise, three-dimensional information about the characteristics of the area being surveyed.¹¹
12. Two LiDAR surveys were luckily available for the Lockyer Valley area. One was taken in August 2010, a few months before the flood, and the other was taken between February and March 2011, just after the flood.¹² Both of those LiDAR surveys revealed the heights of features in the Lockyer Valley, including the Grantham sand plant area.
13. The Department of Natural Resources and Mines advised that the LiDAR surveys were accurate to within 200 mm.¹³

Aerial photography

14. Mr Starr initially considered aerial photographs, provided by the Department of Natural Resources and Mines, taken in 1982, 1988, 1992, 1997, 2001, 2009, 2010 and 2011.¹⁴ The 1982 aerial photograph was of particular importance because, at that time, the quarry operations had only just commenced and most of the site was in its pre-development condition.¹⁵
15. Mr Starr also considered aerial photographs provided by AAM Pty Ltd for 1989, 1995 and 1997 as part of his preparation for the Commission's hearings.¹⁶
16. Mr Starr used these aerial images to perform stereographic analysis. Stereoscopia uses two photographs taken from slightly different points to create a three-dimensional view in which differences in heights are exaggerated, making them easier to discern.¹⁷ By undertaking stereographic analysis, Mr Starr was able to assess the approximate heights of different features and the relative heights of different features shown in the three-dimensional view.

Satellite images

17. Mr Starr also obtained satellite images of the Grantham quarry from Google Earth and Nearmap. The relevant images obtained were dated 30 December 2005, 11 August 2009, 17 July 2010, 12 August 2011 and 10 May 2015.¹⁸
18. Mr Starr used these images with a view to interpreting the changes to the western embankment from 2005 to 2015. In Mr Starr's view, while these images provided some assistance, it was difficult to discern changes in height on the western embankment as opposed to general changes to the features on the embankment over time.¹⁹

Photographs and plans provided in witness statements and submissions

19. Mr Starr also considered the following photographs and plans:
 - (a) oblique air photo of the Grantham quarry included in the submission by Ms Amanda Gearing to the Queensland Floods Commission Of Inquiry (QFCOI), exact date unknown but estimated by Ms Gearing as 1985;²⁰
 - (b) oblique air photo of the Grantham quarry included in the statement of Mr Jonathan Sippel to the Commission with a date of July 1997;²¹
 - (c) oblique air photo of the Grantham quarry included in the statement of Mrs Charmaine Mallon to the Commission, taken in April 2000;²²
 - (d) photo of the Grantham quarry included in the statement of Mr Peter 'John' Gallagher to the Commission, which Mr Gallagher stated was taken in 1996;²³ and
 - (e) survey plan of the Grantham quarry produced by OWR Surveyors dated 6 June 2008.²⁴
 - (f) a survey plan of the Grantham quarry site dated 6 August 1981.²⁵
20. In Mr Starr's view, the photographs provided in witness statements and submissions were useful for the purposes of interpreting changes to the western embankment over time but were not useful for discerning the height of features observed in those photographs. However, Mr Starr considered the survey plans to be quite useful in discerning not only the change to the western embankment over time but also the changes in heights along the length of the western embankment.

Site inspections

21. Mr Starr undertook two site inspections of the Grantham quarry site; first on 1 June 2015 and then again a few weeks later.
22. During the first site inspection, Mr Starr walked around the access track for the Grantham quarry and took a number of photographs of particular features he observed along the access track. These include the north bank of the Grantham quarry lake; an original fence post on the western embankment; terraces along the western side of the Grantham quarry; remnant bunds erected either side of the access track along the western side of the Grantham quarry; erosion to the western embankment to the Grantham quarry; and stockpiles either side of the access track on the southern side of the Grantham quarry.²⁶
23. During the second site inspection, Mr Starr excavated a number of test pits along the western embankment on either side of the access track surrounding the Grantham quarry. This allowed Mr Starr to identify where fill was present on top of natural ground and, where it was present, its depth.²⁷ The location of those test pits is shown in Figure A1.



Figure A1: Test pit locations shown on 2015 Nearmap image.

Source: Exhibit 131, Mr David Starr, *Grantham Quarry – Geotechnical investigations and expert opinion on formation of earthworks, revised 28 August 2015* [p16: Plate 9].

24. A licensed surveyor then recorded the precise location of each pit, the height of the surface level at each test pit, and the height of the surface level at a number of points along the access track. In some pits, the surveyor also recorded the height of the boundary between the upper layer of soil (identified as H1 Fill) and a lower, undisturbed layer (identified as H2 Alluvium).
25. Mr Starr identified the conditions revealed in the test pits using a standard methodology that revealed the extent of natural (H2 Alluvium) as against man-made (H1 Fill) soils, and secured samples of the different soil horizons.

Opinions expressed in Starr main report

Assessment of pre-quarry terrain

26. Mr Starr used the stereoscopic analysis of the 1982 aerial photograph to identify the landform existing before development of the quarry. Combining this information with data from the surveyed levels taken in the test pits, Mr Starr was able to estimate the original ground level and to construct a model of the original ground surface. A copy of that model is at Figure A2 below.
27. Mr Starr had a high degree of confidence in the area of the western embankment as depicted in Figure A2, where accuracy is within 300 mm. Outside of that area, including the area within the pink dashed line, he was reasonably confident in the depiction although he had slightly less confidence in relation to the western side of the lake.²⁸
28. Mr Starr explained that the topography of the ground surface prior to the development of the quarry comprised an alluvial floodplain bounded on three sides by the incised course of the Lockyer Creek. There was a ridge of higher elevation running approximately east-west, which probably overlaid a ridge of weathered Marburg sandstone. The land fell to the north and south of this ridge. To the north, it fell from about 128 metres AHD to about 124 metres AHD at the bank of the northern arm of the Lockyer Creek. To the south of the ridge, the land also fell slightly. A low point of about 122 metres AHD ran from the north end of the western arm of Lockyer Creek to the south eastern corner of the site.²⁹

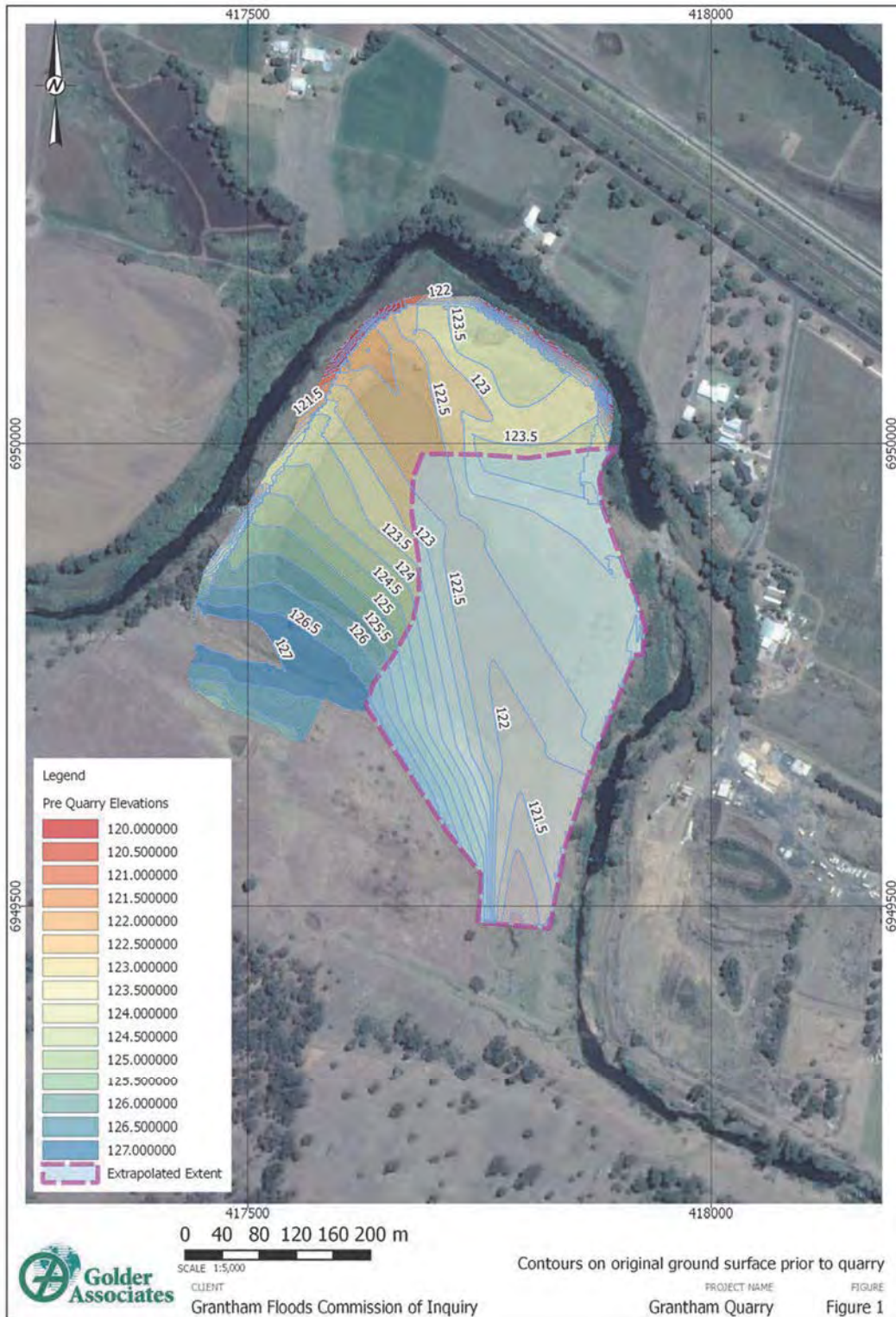

Figure A2: Contours on original ground surface prior to development of the quarry.
 Source: Exhibit 131, Mr David Starr, *Grantham Quarry – Geotechnical investigations and expert opinion on formation of earthworks, Revised 28 August 2015* [p28: Plate 21].

Assessment of the nature of the bunds surrounding the Grantham quarry

29. From his test pit investigations, Mr Starr found several types of soil present on the site.³⁰
30. Along the access track on the western embankment there was a thin layer of sandy fill, sometimes mixed with gravel, up to 0.5 metres deep. Mr Starr considered this might not represent a deliberate attempt to place fill, as it could have resulted from spillage from trucks or as a result of filling in pot holes.
31. Along each side of the access track on the western embankment, there were raised features consisting of sandy clay, with random structure and mixed with gravel and organic material, including gravel of a type of basalt rock not found locally. The random structure and the mixture of materials are consistent with this material being fill.
32. There was also fill material in the north-western end of the quarry site, in the north-east corner and in the southern side of the quarry, which could be mounds of waste material or topsoil, or stockpiles of product. Fill material also appeared to have been used to backfill the main breach at the northern end of the western bund.
33. Beneath the fill material is natural alluvial soil, which is loam to clay in moderately structured layers. This soil is the type that is expected to be found in the Lockyer Valley based on existing geological maps for Queensland. In most cases, the interface between the fill material and the underlying natural alluvial deposits could be clearly recognised as a level boundary between layers of different colour, texture and soil type.
34. Mr Starr identified several features around the quarry that, in his opinion, were man-made:
- two narrow bunds lying either side of the access track on the western embankment;
 - stockpiles of topsoil, product or waste material on the north-western, north-eastern and southern sides of the quarry pit; and
 - fill material used to backfill the main breach at the northern end of the western bund.
35. That they were man-made was indicated by, among other things, the fact that the structure and the type of material differed from the natural soils expected to be found in the Lockyer Valley and included some materials not found naturally in the area.³¹
36. As shown in Figure A3 and Figure A4 below, Mr Starr concluded that the eastern bund (lying on the western embankment between the access track and the quarry pit) was three to four metres in height above the natural ground level though it varied between two metres and six metres, and dipped close to natural ground level in two locations. Near its southern end there was an apparent gap where it dipped to natural ground level and at its northern end it dipped to less than one metre above the natural ground, which was its lowest height.³²
37. A shorter bund (in both height and length) lay on the western side of the access track, between the track and the bank of Lockyer Creek. This was about two metres above natural ground level and ran only half of the length of the eastern bund.³³

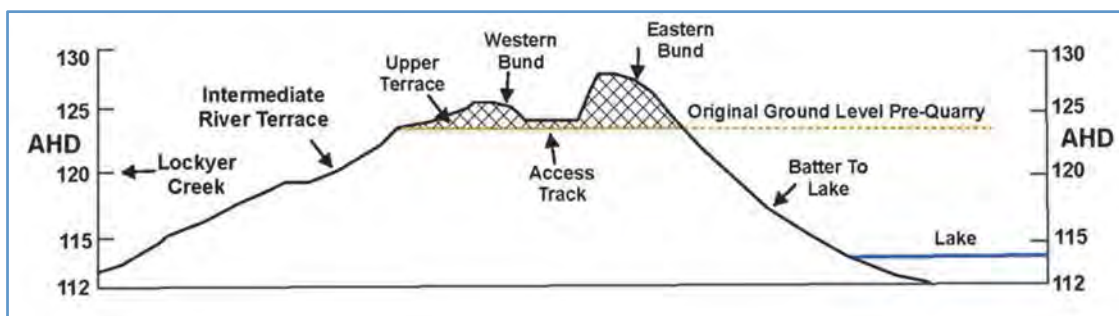

Figure A3: Schematic cross-section through western embankment, Grantham quarry – viewed looking to the north. Source: Exhibit 131, Mr David Starr, *Grantham Quarry – Geotechnical investigations and expert opinion on formation of earthworks*, Revised 28 August 2015 [p1: Plate 1].

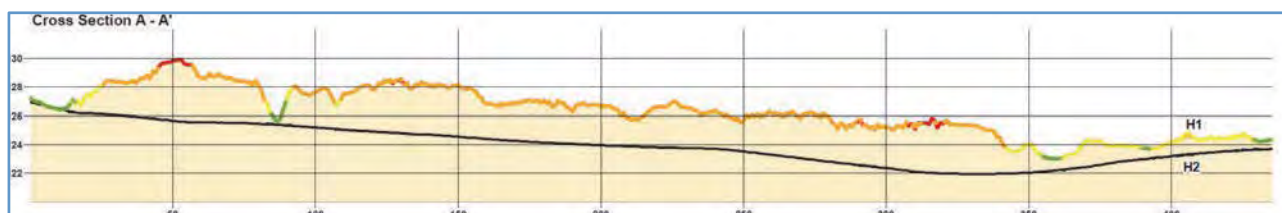

Figure A4: Section through eastern bund along western embankment from south (left) to north (right). Source: Exhibit 131, Mr David Starr, *Grantham Quarry – Geotechnical investigations and expert opinion on formation of earthworks*, Revised 28 August 2015 [p2: Plate 2].

Assessment of the method of construction of the bunds surrounding the Grantham quarry

38. Based on the material in the test pits, Mr Starr concluded that the identified man-made fill was comprised of clayey sandy material. This material may have been sourced from quarrying operations, as there was some evidence from aerial photographs that the material was placed on the embankment by being dumped from a truck or front-end loader. In this respect, Mr Starr referred to stereographic images for 2001 that showed multiple mounds of earth along the western side of the track. Mr Starr estimated those mounds of earth to be about one to two metres in height.³⁴
39. Mr Starr, opinion was that the bunds were not an engineered structure³⁵ and that he could not establish from the test pit data whether or not machinery was used to compact the material.³⁶ Further, with the exception of test pit 119 in the western bund which shows evidence that it was constructed in two stages, Mr Starr did not observe layering in exposed sections of the remnant bunds to indicate construction in layers. However, Mr Starr did identify there was some evidence from his stereographic analysis of aerial photographs that the construction may have occurred in stages.

Assessment of the timing of construction of the bunds surrounding the Grantham quarry

40. In the Starr main report, Mr Starr provided an opinion on the timing of construction of the bunds on the western embankment. This opinion was based on his examination of the photographs of the quarry taken in 1985, 1997, and 2000 provided by witnesses; the survey plan of the site prepared for the Wagners in 2008 and submitted by Wagners; and stereo photo examinations for the years 1997, 2001 and 2009. Mr Starr also considered a Google Earth image dated December 2005³⁷. At the Commission hearing, Mr Starr also discussed his examination of the stereo photographs for 1989, 1995, and additional stereo photos for 1997, provided by AAM.³⁸ These photographs and plans are shown in Figures A5 to A15.

41. Taking these items in chronological order, and combining the information given in the reports and during the hearing, Mr Starr's opinion is that:
- 1982: Examination of the 1982 stereo photos provided by the Department of Natural Resources and Mines showed a generally flat alluvial plain, with no bunds present.



Figure A5: 1982 aerial photo provided by Department of Natural Resources and Mines.
Source: Exhibit 131, Mr David Starr, *Grantham Quarry – Geotechnical investigations and expert opinion on formation of earthworks*, Revised 28 August 2015 [p9: Plate 8]

- 1985: In an oblique aerial view of the quarry stated to be 1985 provided by Ms Gearing, the ground levels between Lockyer Creek and the quarry pit are close to the natural, pre-existing levels, although a change in colour suggests topsoil has been removed.



Figure A6: 1985 oblique aerial photo provided by Ms Gearing
Source: Exhibit 131, Mr David Starr, *Grantham quarry – geotechnical investigations and expert opinion on formation of earthworks*, Revised 28 August 2015 [p35: Plate 25]

- c) **1989:** Mr Starr could not recognise the bunds in the 1989 stereo photos provided by AAM.³⁹



Figure A7: 1989 stereo photo provided by AAM

Source: Exhibit 185, Statement of Raisa Conchin, 29 July 2015 [Attachment B].

- d) **1995:** Examination of the 1995 stereo photos provided by AAM did not show any features in the location of the eastern or western bunds. Mr Starr did however, identify dumps of material evident in the south-western corner of the site, in a location marked by the presence of a power pole.⁴⁰



Figure A8: 1995 stereo photo provided by AAM

Source: Exhibit 54, Exhibit 102: 1995 high resolution aerial photographs.

- e) **1997:** Examination of the August 1997 stereo photos provided by the Department of Natural Resources and Mines showed no evidence of bunds on the western embankment. The photos showed an upper and a lower bench excavated below natural ground level between the embankment and the quarry lake, with a haul road running from the north-west corner down onto the upper terrace. The mounds of material in the south-western corner evident in the 1995 stereo photos appear to have been made into an access track, possibly by compacting them with machinery.⁴¹



Figure A9: 1997 aerial photo provided by DNRM.

Source: Exhibit 131, Mr David Starr, Grantham quarry – geotechnical investigations and expert opinion on formation of earthworks, Revised 28 August 2015 [p42: Plate 31A]

- f) Additional stereo photos for 1997 provided by AAM showed the access track more clearly. In Mr Starr’s view, the track may have been a little bit below the level of the land to the east and west, perhaps by 0.5 metres. The AAM photos also showed that the western edge of the upper bench is close to the eventual limit of the west side of the quarry lake.⁴²



Figure A10: stereo photos for 1997 provided by AAM

Source: Exhibit 104: 1997 high resolution aerial photographs.

- g) **2000:** Mr Starr could not comment on the presence of bunds in an oblique aerial photograph provided by Mrs Mallon, which is verified as taken in 2000, as the field of view cuts off the area along the western embankment.



Figure A11: 2000 Oblique aerial photo provided by Ms Mallon
 Source: Statement by Charmaine Mallon, 1 July 2015 []; Exhibit 131, Mr David Starr, *Grantham quarry – geotechnical investigations and expert opinion on formation of earthworks*, Revised 28 August 2015 [p37 Plate 27a]

- h) **2001:** Examination of the June 2001 stereo photos provided by the Department of Natural Resources and Mines showed a western bund made of multiple mounds of material, apparently formed by repeated dumping from a truck or front-end loader. Mr Starr estimated the mounds were one to two metres in height, and was fairly certain the western bund is higher than any feature in that location shown in the 1997 photographs.⁴³

Mr Starr also identified an eastern bund, which appeared less wide and less high than the western bund, and which may also have been formed by repeated dumping from a front-end loader. Further, Mr Starr identified the upper bench and the extraction area next to the quarry lake in the photograph. The access track appeared to have been moved to the west compared to 1997, and the lake had extended further to the west.



Figure A12: 2001 aerial photo provided by the DNRM (annotations by David Starr).
 Source: Exhibit 131, Mr David Starr, *Grantham quarry – geotechnical investigations and expert opinion on formation of earthworks*, Revised 28 August 2015 [p43: Plate 32b]

- i) **2005:** The Google Earth image taken in December 2005 appeared to indicate the presence of the bunds in a similar form to those shown in the 2008 survey plan, though Mr Starr was not able to determine the height of these bunds from the 2005 image as it is not in stereo.⁴⁴



Figure A13: 2005 Google Earth image.

Source: Exhibit 131, Mr David Starr, *Grantham quarry – geotechnical investigations and expert opinion on formation of earthworks*, Revised 28 August 2015 [Appendix C]

- j) **2008:** A survey plan provided by the Wagners indicated the bunds had been formed either side of the access track on the western side of the quarry lake, with maximum heights of 128.5 metres AHD on the eastern bund and 126.4 metres AHD on the western bund. The heights were essentially the same as those shown in the 2010 LiDAR contour plans, allowing for the difference in mapping techniques. There was nothing like that height in the 2001 photographs.⁴⁵

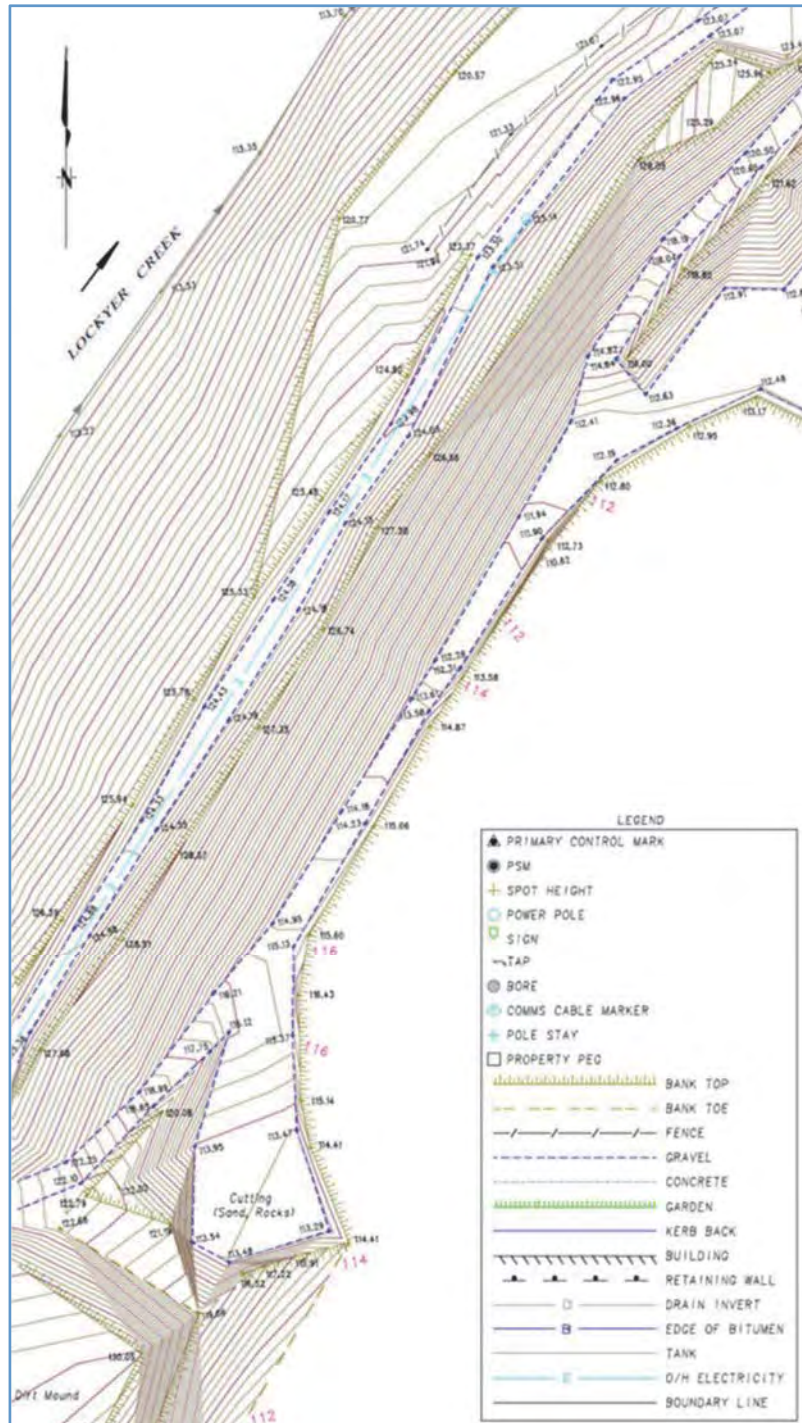

Figure A14: Detail from survey plan of Grantham quarry prepared for Wagners in 2008
 Source: Exhibit 131, Mr David Starr, *Grantham quarry – geotechnical investigations and expert opinion on formation of earthworks*, Revised 28 August 2015 [p39: Plate 29]

- k) **2009:** Examination of the 2009 stereo photos provided by the Department of Natural Resources and Mines show the bunds either side of the access track were very similar to those seen in the 2010 pre-flood LiDAR imagery. The track had moved since 2001 to cut through the western bund at its northern end.



Figure A15: 2009 annotated aerial photo.

Source: Exhibit 131, Mr David Starr, *Grantham quarry – geotechnical investigations and expert opinion on formation of earthworks*, Revised 28 August 2015 [p44: plate 33]

42. Based on this analysis, Mr Starr's opinion was that the construction of the bunds either side of the access track along the western embankment commenced after August 1997 and before June 2001. Mr Starr considered it was possible the bunds were in place in their pre-flood form by 2005, but this was not certain, as there were no stereoscopic photos available for this time. However, the 2008 survey confirms that by then the bunds were essentially the same location and height as those shown in the 2010 LiDAR contour plans.

Opinion as to the broken pole

43. For the Starr first supplementary report, Mr Starr relied on his analysis of the information gathered during the first site inspections and the Nearmap imagery for 2010 and 2015. Mr Starr also relied on the findings in the Starr main report as to the pre-flood contours for the Grantham quarry and, in particular, the pre-flood contours for the area where the broken pole was located.⁴⁶
44. Based on this analysis, Mr Starr's opinion was that:⁴⁷
- the location of the broken pole and its proximity to the bund to the south east of the pole is the same as is shown in the 2010 photograph, and to the east of the broken pole there is the slope of the eastern bund along the western side of the Grantham quarry;
 - the surface level at the base of the broken pole was between 122.5 metres AHD and 123.5 metres AHD;
 - the peak of the slope to the south east of the broken pole (on the western embankment) was approximately 126.5 metres AHD;
 - the distance between the broken pole and the base of the bund to the south east of the broken pole was between one metre to two metres;
 - the horizontal distance from the broken pole to the top of the bund to the south east of the broken pole was between seven metres to eight metres; and
 - the bund to the east of the broken pole had a slope which, on the side of the broken pole, was at an angle of 35 degrees.

45. Mr Starr produced an image that summarised his views concerning the location of the broken pole.⁴⁸ A copy of that image is reproduced below.

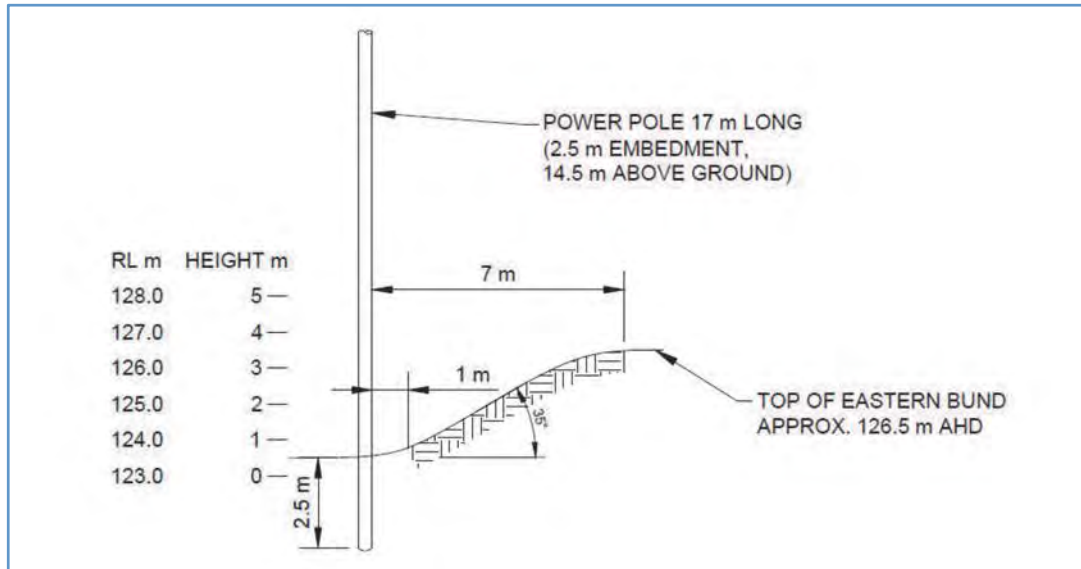

Figure A16: Cross section through the eastern bund adjacent to the broken pole.

Source: Exhibit 131, Mr David Starr, *Grantham Quarry – Geotechnical Investigations and Expert Opinion on Formation of Earthworks – Supplementary Report concerning location of failed power pole P182127, Revised 28 August 2015* [p8: para 38].

Overall conclusions expressed in Starr second supplementary report

46. For the Starr second supplementary report, Mr Starr relied on his analysis of the 1982 aerial photograph taken over the Grantham quarry site as well as a survey plan of the Grantham quarry site dated 6 August 1981. In addition, Mr Starr relied on the findings in the Starr main report as to the pre-flood contours for the Grantham sand plant and in particular, the pre-flood contours derived from LiDAR data taken over the quarry area in August 2010.⁴⁹
47. From his analysis of the 1982 aerial photograph, Mr Starr identified that it showed there was already some development on the site, with settling ponds excavated and some areas affected by earthworks. However, Mr Starr's stereoscopic examination of the photograph showed there was:⁵⁰
- an undisturbed flat area between the crest of the left bank of Lockyer Creek and the earthworks;
 - a river terrace part way down the bank; and
 - a small area to the east of the batching plant which was at a slightly higher elevation than the flat area remaining.
48. In Mr Starr's opinion, these areas probably had the same elevation before the quarry development.
49. By comparing the 1982 photograph with the 1981 survey plan and the 2010 LiDAR data, Mr Starr was able to form an opinion about the heights of these areas – the terrace, the flat and the elevated area. In Mr Starr's view⁵¹:
- the original flat surface was at about 124 metres AHD;
 - the elevated area in the north-east of the site was at 124.5 metres AHD
 - the river terrace is at about 120 metres AHD.

50. Mr Starr created a contour plan of the plant area showing his conclusions as to the pre-quarry terrain for that area⁵² (Figure A17).



Figure A17: Reconstructed topographic plan of Batching Plant Site prior to development.

Source: Exhibit 303, Mr David Starr , *Grantham Quarry - Geotechnical Investigations and expert opinion on formation of earthworks - Supplementary report concerning pre-quarry terrain at sand batching plant*, 2 September 2015 [p5: Plate 3].

Issues raised regarding Mr Starr's findings

51. The Commission received a number of submissions raising issues regarding Mr Starr's opinions. The submissions concerned the reliability of Mr Starr's opinions as to the likely height of the western embankment as at January 2011 and the likely period over which the bunds on the western embankment were constructed.

The likely height of the western embankment as at January 2011

52. The submission as to the likely height of the western embankment focused on a cross-section prepared by Mr Starr along the length of the western embankment. That cross-section is reproduced in Figure A4.
53. Mr Starr's opinion was that the eastern bund was about four metres in height above natural ground level, but varied between two metres and six metres.⁵³ While it was accepted that the black line shown in the cross-section accurately identified the level of natural ground, it was submitted that this cross-section did not support Mr Starr's findings as to the height of man-made fill above natural ground.⁵⁴ The effect of the submission was that the bund was not as high as determined by Mr Starr.

54. There were two reasons given in support of this submission:
- a) the cross-section showed that:
 - (i) there were only two points where the bund exceeded four metres in height;⁵⁵
 - (ii) there were two points where the bund did not exceed ground level;⁵⁶
 - (iii) the southern end (the left side of the cross-section) mistakenly showed the height of the eastern bund as six metres when in fact, that height was attributable to a stockpile rather than the bund itself;⁵⁷ and
 - (iv) the bund generally does not exceed two metres in height.⁵⁸
 - b) Mr Starr had acknowledged a mistake at chainage 320 on the cross-section wherein he had not drawn a complete accurate cross-section of the eastern bund at that location because the cross-section did not pass through the highest point at that location.⁵⁹
55. As to the second point, Mr Starr acknowledged that he had made an error and that the cross-section understated the full height of the bund in that location because the cross-section was not drawn through the highest point. It was not suggested Mr Starr was wrong to say that the actual height of the bund was higher in that location than is depicted in the cross-section. That is apparent from Figure 1A to the Starr main report.⁶⁰ It follows that, properly understood, this point supports rather than detracts from Mr Starr's opinion as to the height of the bunds.
56. As to the remainder of the submission, during the Commission's hearing, Mr Starr expressed the opinion that he would guess the average height of the eastern bund, if the southern stockpile was excluded, was roughly 3.5 metres above natural ground level.⁶¹ Contrary to the submission that was made, it is apparent from the cross-section that the bund generally did exceed two metres in height above natural ground level.
57. I accept Mr Starr's opinion. In any event, I note three further matters.
58. First, it is quite apparent from a consideration of all of the photographic evidence that the eastern bund was of a substantial height along a significant proportion, though certainly not all, of its length.
59. Second, the relevant substantive matters about which Mr Starr expressed an opinion were the natural ground level and what the LiDAR surveys showed as to the height of the bunds at the time the flood occurred. There was no challenge to these opinions. The submission challenging Mr Starr's opinion as to the height of the bunds was concerned with concluding statements that Mr Starr made about what could be observed from a comparison between the natural ground level, as he assessed it to be, and the LiDAR surveys showing the bunds as they were at the time of the floods. The effect of Mr Starr's opinion was that the bunds were of a very substantial height above natural ground level. I accept they were and so much can be observed without needing to rely on Mr Starr's concluding opinion as to this matter. Indeed, the height of part of the eastern bund was still well above head level when I saw it before the hearings.
60. Third, and in any event, as there is no challenge to Mr Starr's opinion as to the natural ground level, these matters do not have any bearing on the opinions of the Commission's expert hydraulic engineer, Dr Macintosh, who relied on Mr Starr's opinion as to the natural ground level for his modelling but was otherwise able to use directly the LiDAR survey taken as at August 2010. As discussed in Appendix C, Dr Macintosh used this terrain as part of his assessment of the impact of the Grantham quarry on the flooding in Grantham.

The likely period over which the bunds were constructed

61. It was suggested in submissions that Mr Starr's opinion as to the period over which the bunds were constructed was not reliable. Two reasons were given in support of this submission:
- a) insofar as Mr Starr relied on stereographic analysis of aerial images, his opinion was irrelevant as anyone would be in as good a position as Mr Starr to review the stereo pair photographs and draw conclusions as to what is shown in them;⁶² and
 - b) Mr Starr had wrongly interpreted the orientation of certain aerial photographs referred to in witness statements, when providing his opinion.⁶³
62. As to the first reason, I do not accept that anybody is in just as good a position as Mr Starr to review the stereo pair photographs and draw conclusions as to what is shown in them. Mr Starr has many years of experience in reviewing stereographic images and comparing those images to what he has observed on site and this has necessarily contributed to his expertise and enhanced his ability to identify features and make a judgment as to the relative heights of those features and whether the vegetation is likely to be of such a density as to obscure the ground underneath.
63. As to the second reason, it is contended that Mr Starr was mistaken when he observed that:⁶⁴
- a) a photograph taken by Mr J Gallagher was taken looking directly south west towards Klucks Road when in fact the photograph was taken looking north west;
 - b) a photograph provided by Mrs Mallon did not show part of the eastern bund, when in fact the photograph showed the northern end of the eastern bund; and
 - c) a photograph provided by Mr Sippel did not appear to show bunds along the western embankment, when in fact the photograph showed the western embankment with the bunds clearly shown.
64. During the hearing, Mr Starr conceded he was mistaken in the orientation of the first of these photographs.⁶⁵ On my request, Mr Starr produced a revised version of his report which deleted the paragraphs in his report containing his views concerning this photograph.
65. As to the remaining photographs, I note that:
- a) during the hearing, Mr Starr did not accept he was mistaken in the orientation of Mrs Mallon's photographs;⁶⁶
 - b) Mr Starr was not asked to consider and consequently, has not accepted, he was mistaken as to the orientation of Mr Sippel's photographs.
66. In any event, these photographs were not the basis of Mr Starr's opinion. Mr Starr expressed the opinion that these types of photographs while useful, are not as reliable as LiDAR data, stereo aerial photography or survey plans in determining height information, which was the material upon which Mr Starr had relied.
67. For the reasons addressed in Chapter 3, even setting aside Mr Starr's evidence, the overwhelming effect of the evidence is that the bunds were modified and increased in size after 2001. That, of course, is consistent with Mr Starr's opinion based on his examination of the material available to him. I accept Mr Starr's opinion.

Reliability of Mr Starr's opinion

68. In my view, and having had the benefit of hearing Mr Starr's evidence, I do not accept that any of the issues raised substantively affect the reliability of the opinions expressed by Mr Starr and I accept those opinions.

- ¹ Exhibit 131, Mr David Starr, *Grantham quarry – geotechnical investigations and expert opinion on formation of earthworks*, Revised 28 August 2015 [p7: para 25 - 30].
- ² Exhibit 131, Mr David Starr, *Grantham quarry – geotechnical investigations and expert opinion on formation of earthworks*, Revised 28 August 2015 [p1: para 1]; Transcript 6 August 2015: David Starr [p987: line 33 - 41].
- ³ Exhibit 131, Mr David Starr, *Grantham quarry – geotechnical investigations and expert opinion on formation of earthworks*, Revised 28 August 2015.
- ⁴ Exhibit 131, Mr David Starr, Cross-Sections C and D.
- ⁵ Exhibit 131, Mr David Starr, Figure 9 – Pre-flood compared to post-flood elevations and volume calculations.
- ⁶ Exhibit 132, Mr David Starr, Digital video files relating to evidence of Mr David Starr.
- ⁷ Exhibit 131, Mr David Starr, *Grantham quarry – geotechnical investigations and expert opinion on formation of earthworks – supplementary report concerning location of failed power pole P182127*, Revised 28 August 2015 [p1: para 4].
- ⁸ Exhibit 131, Mr David Starr, *Grantham quarry – geotechnical investigations and expert opinion on formation of earthworks, supplementary report concerning location of failed power pole P182127*, Revised 28 August 2015.
- ⁹ Exhibit 303, Mr David Starr, *Grantham quarry - geotechnical investigations and expert opinion on formation of earthworks - supplementary report concerning pre-quarry terrain at sand batching plant*, 2 September 2015 [p1, para 7].
- ¹⁰ Exhibit 303, Mr David Starr, *Grantham quarry - geotechnical investigations and expert opinion on formation of earthworks - supplementary report concerning pre-quarry terrain at sand batching plant*, 2 September 2015.
- ¹¹ Exhibit 131, Mr Mr David Starr, *Grantham quarry – geotechnical investigations and expert opinion on formation of earthworks*, Revised 28 August 2015 [p11: para 40].
- ¹² Exhibit 131, Mr David Starr, *Grantham quarry – geotechnical investigations and expert opinion on formation of earthworks*, Revised 28 August 2015 [p11: para 39].
- ¹³ Exhibit 131, Mr David Starr, *Grantham quarry – geotechnical investigations and expert opinion on formation of earthworks*, Revised 28 August 2015 [p11: para 41]; Transcript 6 August 2015: David Starr [p989: line 8 - 21].
- ¹⁴ Exhibit 131, Mr David Starr, *Grantham quarry – geotechnical investigations and expert opinion on formation of earthworks*, Revised 28 August 2015 [p41, para 153]; Transcript 6 August 2015: David Starr, [p991: lines 11 - 15].
- ¹⁵ Exhibit 131, Mr David Starr, *Grantham quarry – geotechnical investigations and expert opinion on formation of earthworks*, Revised 28 August 2015 [p25 para 105 - p27: para112].
- ¹⁶ Transcript 6 August 2015: David Starr [p 990: line 1 - p991: line 9].
- ¹⁷ Transcript 6 August 2015: David Starr [p 990: line 1 - p991: line 9].
- ¹⁸ Exhibit 131, Mr David Starr, *Grantham quarry – geotechnical investigations and expert opinion on formation of earthworks*, Revised 28 August 2015 [p11 - p12: para 48]; Transcript 6 August 2015, Gatton: Mr David Starr [p992: lines 14 - 26].
- ¹⁹ Exhibit 131, Mr David Starr, *Grantham quarry – geotechnical investigations and expert opinion on formation of earthworks*, Revised 28 August 2015 [p12: para 49].
- ²⁰ Submission of Ms Amanda Gearing to the Queensland Floods Commission of Inquiry entitled 'Submission to the Queensland Floods Commission of Inquiry, Issues re Grantham quarry and flooding upstream and downstream', 7 November 2011.
- ²¹ Exhibit 25b, Statement of Jonathan Sippel, 1 July 2015 [Attachment JS-1].
- ²² Exhibit 225, Statement of Charmaine Mallon, 2 July 2015 [Attachment CDM-4].
- ²³ Exhibit 45, Statement of Patrick John Gallagher, 1 July 2015 [Attachment PJG-1].
- ²⁴ Exhibit 107, OWR Surveyors, Survey Plan of Grantham Quarry, 6 June 2008.
- ²⁵ Exhibit 108, Parkinson and Parkinson Surveyors, Survey Plan of Grantham Quarry, 6 August 1981.
- ²⁶ Exhibit 131, Mr David Starr, *Grantham quarry – geotechnical investigations and expert opinion on formation of earthworks*, Revised 28 August 2015 [p13: para 52 - p15: para 67].
- ²⁷ Exhibit 131, Mr David Starr, *Grantham quarry – geotechnical investigations and expert opinion on formation of earthworks*, Revised 28 August 2015 [p16: para 69].
- ²⁸ Transcript 6 August 2015: David Starr [p1004: lines 19 - 41].
- ²⁹ Exhibit 131, Mr David Starr, *Grantham quarry – geotechnical investigations and expert opinion on formation of earthworks*, Revised 28 August 2015 [p27: para 108 - 112].
- ³⁰ Exhibit 131, Mr David Starr, *Grantham quarry – geotechnical investigations and expert opinion on formation of earthworks*, Revised 28 August 2015 [Section 8.2]; Transcript 6 August 2015: David Starr [p999: line 45 - p1000: line 42].
- ³¹ Exhibit 131, Mr David Starr, *Grantham quarry – geotechnical investigations and expert opinion on formation of earthworks*, Revised 28 August 2015 [Section 8.2]; Transcript 6 August 2015: David Starr [p999: line 145 - p1000: line 42].
- ³² Exhibit 131 Mr David Starr, *Grantham quarry – geotechnical investigations and expert opinion on formation of earthworks*, Revised 28 August 2015 [Section 10]; Transcript 6 August 2015: David Starr [p1013: line 38 - p1014: line 7].
- ³³ Exhibit 131, Mr David Starr, *Grantham quarry – geotechnical investigations and expert opinion on formation of earthworks*, Revised 28 August 2015 [section 10].
- ³⁴ Exhibit 131, Mr David Starr, *Grantham quarry – geotechnical investigations and expert opinion on formation of earthworks*, Revised 28 August 2015 [Section 13].
- ³⁵ Transcript 6 August 2015: David Starr [p1039: line 37 - p1038: line 6].
- ³⁶ Transcript 6 August 2015: Mr David Starr [p999: line 44 - p1000: line 6; p1005: lines 5-15].

- ³⁷ Exhibit 131, Mr David Starr, *Grantham quarry – geotechnical investigations and expert opinion on formation of earthworks*, Revised 28 August 2015 [Section 12 and Section 13].
- ³⁸ Exhibits 102, 103, 104; Transcript 6 August 2015, David Starr [p1005: line 17 - p1013: line 36].
- ³⁹ Transcript 6 August 2015: David Starr [p1007 lines 5 – 8]
- ⁴⁰ Transcript 6 August 2015: David Starr [p1005 line 26 – p1006 line 7]
- ⁴¹ Transcript 6 August 2015: David Starr [p1006 lines 9 – 37]
- ⁴² Transcript 6 August 2015: David Starr [p1007 line 21 – 3p 1008 line 12]
- ⁴³ Transcript 6 August 2015: David Starr [p1009 lines 1-7]
- ⁴⁴ Transcript 6 August 2015: David Starr [p1012 lines 30 - 40]
- ⁴⁵ Transcript 6 August 2015: David Starr [p1013 lines 13 - 35]
- ⁴⁶ Exhibit 131, Mr David Starr, *Grantham quarry – geotechnical investigations and expert opinion on formation of earthworks – supplementary report concerning location of failed power pole P182127*, Revised 28 August 2015 [p2: para 11].
- ⁴³ Exhibit 131, Mr David Starr, *Grantham quarry – geotechnical investigations and expert opinion on formation of earthworks – supplementary report concerning location of failed power pole P182127*, Revised 28 August 2015 [p8: para 38].
- ⁴⁸ Exhibit 131, Mr David Starr, *Grantham quarry – geotechnical investigations and expert opinion on formation of earthworks – supplementary report concerning location of failed power pole P182127*, Revised 28 August 2015 [p7: Plate 6].
- ⁴⁹ Exhibit 303, Mr David Starr, *Grantham quarry - geotechnical investigations and expert opinion on formation of earthworks - supplementary report concerning pre-quarry terrain at sand batching plant*, 2 September 2015 [p1: para 12].
- ⁵⁰ Exhibit 303, Mr David Starr, *Grantham quarry - geotechnical investigations and expert opinion on formation of earthworks - supplementary report concerning pre-quarry terrain at sand batching plant*, 2 September 2015 [p3: para 22 - p4: para 23].
- ⁵¹ Exhibit 303, Mr David Starr, *Grantham quarry - geotechnical investigations and expert opinion on formation of earthworks - supplementary report concerning pre-quarry terrain at sand batching plant*, 2 September 2015 [p4: para 23].
- ⁵² Exhibit 303, Mr David Starr, *Grantham quarry - geotechnical investigations and expert opinion on formation of earthworks - supplementary report concerning pre-quarry terrain at sand batching plant*, 2 September 2015 [p5: para 27].
- ⁵³ Exhibit 131, Mr David Starr, *Grantham quarry – geotechnical investigations and expert opinion on formation of earthworks*, Revised 28 August 2015, [p11: para 9].
- ⁵⁴ Closing submissions made on behalf of Wagner Investments Pty Ltd and Wagners Australian Operations Pty Ltd, 28 August 2015 [pp13–14: para 34].
- ⁵⁵ Closing submissions made on behalf of Wagner Investments Pty Ltd and Wagners Australian Operations Pty Ltd, 28 August 2015 [p14: paras 36 and 37].
- ⁵⁶ Closing submissions made on behalf of Wagner Investments Pty Ltd and Wagners Australian Operations Pty Ltd, 28 August 2015 [p14: para 38].
- ⁵⁷ Closing submissions made on behalf of Wagner Investments Pty Ltd and Wagners Australian Operations Pty Ltd, 28 August 2015 [p14: para 38].
- ⁵⁸ Closing submissions made on behalf of Wagner Investments Pty Ltd and Wagners Australian Operations Pty Ltd, 28 August 2015 [p16: para 41].
- ⁵⁹ Closing submissions made on behalf of Wagner Investments Pty Ltd and Wagners Australian Operations Pty Ltd, 28 August 2015 [p14: para 39].
- ⁶⁰ Exhibit 131, Mr David Starr, *Grantham quarry – geotechnical investigations and expert opinion on formation of earthworks*, Revised 28 August 2015 [Figure 1A].
- ⁶¹ Transcript 6 August 2015: David Starr [p1033: L30 - 45].
- ⁶² Closing submissions made on behalf of Wagner Investments Pty Ltd and Wagners Australian Operations Pty Ltd, 28 August 2015 [p20: para 51].
- ⁶³ Closing submissions made on behalf of Wagner Investments Pty Ltd and Wagners Australian Operations Pty Ltd, 28 August 2015 [p26: para 26 - p31: para 73].
- ⁶⁴ Closing submissions made on behalf of Wagner Investments Pty Ltd and Wagners Australian Operations Pty Ltd, 28 August 2015 [p26: para 26 - p31: para 73].
- ⁶⁵ Transcript 6 August 2015: David Starr [p1034: line 39 - p1035: line 9].
- ⁶⁶ Transcript 6 August 2015: David Starr [p1030: line 28 – p1031: line 20].

Appendix B: Expert advice – Investigation of failed timber utility pole

1. It was suggested in submissions by some interested parties that a broken timber utility pole on the site of the Grantham sand plant might give an indication of either the height of the western embankment of the Grantham quarry or the height of floodwaters at that location.¹ Given these submissions, the Commission engaged a timber expert, Mr Colin MacKenzie.

Mr MacKenzie's qualifications and experience

2. Mr MacKenzie is a Registered Professional Engineer and a fellow of the Institute of Engineers Australia. He has over 35 years' experience in timber engineering and timber technology, having previously worked in a number of roles including as a technical officer for the CSIRO Division of Forest Products and as an engineer and technical director for the Timber Research and Development Advisory Council. Mr MacKenzie is presently the Principal of MacKenzie Consulting.²

Scope of work performed by Mr MacKenzie

3. Mr MacKenzie was engaged to provide an opinion on the likely cause or causes of failure to the broken pole.³ In providing his opinion, Mr MacKenzie was specifically asked to consider the hypothesis that the failure of the pole was caused or contributed to by an embankment to the south east side of the pole, and to the west of the Grantham quarry pit.⁴
4. Mr MacKenzie provided an expert report to the Commission entitled *Report to: Grantham Commission of Inquiry – Investigation of timber utility pole failure* on 27 July 2015.⁵ Mr MacKenzie also gave evidence concerning his report during the Commission's hearing on 3 August 2015.

Key information relied on by Mr MacKenzie

5. Energex provided a statement to the Commission about the construction, inspection and decommissioning of the local electricity distribution network.⁶ This included advice about:
 - a) the availability of the top section of the broken pole and any associated cross-arm attachments for inspection;
 - b) the normal height for the test point for power poles;
 - c) the usual installation height of the ID disc for the power poles;
 - d) the sinking depth for the broken pole;
 - e) the lengths between the king bolts and the top of the pole, the cross-arm and the stays; and
 - f) a reasonable horizontal tip load (action) to be applied to the broken pole assuming any external action (such as wind or floods).
6. The Commission provided this statement to Mr MacKenzie together with an aerial photograph taken in July 2010 showing the location of the broken pole in relation to the embankment to the south-east of the pole.

- Mr MacKenzie undertook a site inspection of the Grantham quarry, took measurements and photographs of the broken pole, and collected a small sample of the broken pole to be analysed to identify the timber species.⁷

Location and properties of the broken pole

Location of the broken pole

- The broken pole (pole number 182127) is located on the embankment on the western side of the Grantham quarry, between the quarry pit and the Lockyer Creek, ⁸ as shown in Figure B1 below.



Figure B1: Location and connections for the broken pole.

Source: Exhibit 70, Statement by Ron Barbagallo, Energex, 25 June 2015 – Attachment RAB-1. Note that P182127 is incorrectly referred to as Spotted Gum while timber analysis of a sample taken by Mr MacKenzie identifies the species as Blackbutt.

Properties of the broken pole

- The timber species of the broken pole is Blackbutt.⁹ The pole was installed in 1990, and was equipped with two stays.¹⁰ Mr MacKenzie observed that the break in the broken pole extended from 5.8 metres above ground on the highest point to 4.8 metres on the lowest point¹¹ and there was scouring evident at the base of the broken pole.¹² He noted that the broken pole was leaning at an angle of 28 degrees to the vertical towards the south east.¹³ The fibres at both the top and the bottom of the break also leaned to the south-east.¹⁴ There were signs of compression damage¹⁵ and there was a small plug of fibres which had been pulled up.¹⁶
- Mr MacKenzie produced a photograph of the broken pole identifying some of these features (Figure B2).

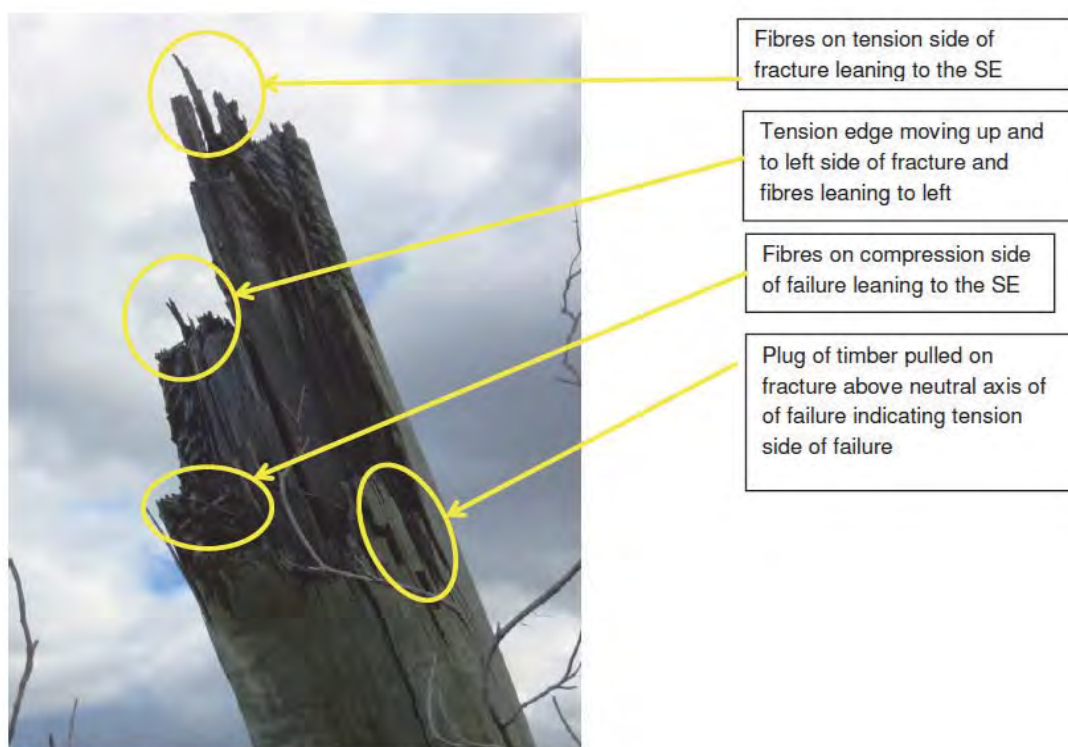

Photo 19 – Pole fracture from the NE

Figure B2: Pole fracture viewed from the north east.

Source: Exhibit 55, Mr Colin MacKenzie, *Investigation of timber utility pole failure*, Revised 4 August 2015 [p43: photo 19].

Assessment of likely causes of failure of the broken pole

11. Mr MacKenzie concluded that the force applied to the pole which caused it to break was applied either above the fracture in a south-easterly direction, or below the fracture in a north-westerly direction.¹⁷
12. Mr MacKenzie considered a range of possible scenarios that could have caused the pole to break in this way.¹⁸ As the water was flowing in a south-easterly direction it was unlikely the break would have been caused by a north-westerly impact,¹⁹ and as the maximum flow height for the flood was below the fracture point it was unlikely the force of the water or debris in the water hitting the pole could have pushed it over. Mr MacKenzie's opinion was that it was possible, although not as likely as the most probable cause, that if the debris in some way "rode up" the pole to place a larger load on the tip of the pole, that could have broken the pole. Debris hitting the stays or the loss of the stays could not, by themselves, have caused the pole to break in the way it did.²⁰
13. Mr MacKenzie concluded that the most likely cause of failure was a load applied close to the top of the pole, which then caused the pole to deflect and bend to the south-east in the direction of failure.²¹ The most likely source of the load on the top of the pole would be from debris snagged in the conductors (between the broken pole and 182128, and possibly also between the broken pole and 182126). If the flood peaked at about 129 metres AHD (which was just above the peak modelled by Dr Macintosh), then the debris would have needed to protrude only about one metre above the water to meet the conductors. If the stays failed first, the pole may have started to lean, further reducing the height of the conductors above the water. It is also possible that debris directly impacted on pole

182128, ripping it out entirely, which pulled on the conductors that had been attached to the broken pole. In either case, the conductors were more than strong enough to bear a load sufficient to snap the pole.²²

14. Mr MacKenzie examined the heights of the ground surface at the base of the pole and the batter angle of the eastern bund (as calculated by Mr Starr). His opinion was that the eastern bund did not have an effect on the fracture of the pole, as the pole did not lean over sufficiently to make contact with the bund. Even if the ground around the pole had been a metre or two higher than determined through Mr Starr's analysis, it would not have had any bearing on the fracture location.²³
15. Finally, Mr MacKenzie's opinion was that the location of the break along the pole did not provide direct evidence of the peak height of the flood. The location of the break was a result of the properties of the timber pole itself, such as the inherent strength of that species of timber and the dimensions of the pole. Mr MacKenzie calculated the pole's properties and found the pole *in situ* had its greatest stresses (under either shock or static loading) five to six metres above ground. It was therefore not unexpected the pole failed at this point.²⁴

Reliability of Mr MacKenzie's opinion

16. I accept Mr MacKenzie's opinion and I note the Commission has not received any submission that suggests I should not do so.

¹ Submission of Peter John Gallagher, 2 July 2015, [p6-7]; Submission of John Gillespie, 2 July 2015 [p4-7; p9-10]; Submission of Amanda Gearing, 3 July 2015, [p21].

² Exhibit 55, Mr Colin MacKenzie, *Investigation of timber utility pole failure*, Revised 4 August 2015 [p5: para 3.1]; Transcript, 3 August 2015: Colin Mackenzie [p722: line 43 - p723: line 21].

³ Exhibit 55, Mr Colin MacKenzie, *Investigation of timber utility pole failure*, Revised 4 August 2015 [p5, para 2.1]; Transcript, 3 August 2015: Colin Mackenzie, [p722: line 43 - p723: line 21].

⁴ Exhibit 55, Mr Colin MacKenzie, *Investigation of timber utility pole failure*, Revised 4 August 2015 [p54: Appendix 5].

⁵ Exhibit 55, Mr Colin MacKenzie, *Investigation of timber utility pole failure*, Revised 4 August 2015.

⁶ Exhibit 70: Statement of Ron Barbagallo 25 June 2015.

⁷ Exhibit 55, Mr Colin MacKenzie, *Investigation of timber utility pole failure*, Revised 4 August 2015 [p8: para 6.1 - p14: para 6.8.2].

⁸ Exhibit 55, Mr Colin MacKenzie, *Investigation of timber utility pole failure*, Revised 4 August 2015 [p7: Image 1]; Transcript, 3 August 2015: Colin Mackenzie, [p723: line 23 - p724: line 10].

⁹ Exhibit 55, Mr Colin MacKenzie, *Investigation of timber utility pole failure*, Revised 4 August 2015, [p3: para 1.5(b)].

¹⁰ Exhibit 70, Statement by Ron Barbagallo, 25 June 2015, Attachments RAB-3 and RAB-4.

¹¹ Exhibit 55, Mr Colin MacKenzie, *Investigation of timber utility pole failure*, Revised 4 August 2015, [p19: para 8.1].

¹² Exhibit 55, Mr Colin MacKenzie, *Investigation of timber utility pole failure*, Revised 4 August 2015 [p11: para 6.5].

¹³ Exhibit 55, Mr Colin MacKenzie, *Investigation of timber utility pole failure*, Revised 4 August 2015, [p8-9: para 6.2].

¹⁴ Exhibit 55, Mr Colin MacKenzie, *Investigation of timber utility pole failure*, Revised 4 August 2015 [p14: para 6.8.1].

¹⁵ Exhibit 55, Mr Colin MacKenzie, *Investigation of timber utility pole failure*, Revised 4 August 2015 [p14: para 6.8.1].

¹⁶ Exhibit 55, Mr Colin MacKenzie, *Investigation of timber utility pole failure*, Revised 4 August 2015 [p14: para 6.8.1].

¹⁷ Exhibit 55, Mr Colin MacKenzie, *Investigation of timber utility pole failure*, Revised 4 August 2015 [p14: para 6.8.2].

¹⁸ Exhibit 55, Mr Colin MacKenzie, *Investigation of timber utility pole failure*, Revised 4 August 2015 [p20-23, para 8.3].

¹⁹ Exhibit 55, Mr Colin MacKenzie, *Investigation of timber utility pole failure*, Revised 4 August 2015 [p20].

²⁰ Exhibit 55, Mr Colin MacKenzie, *Investigation of timber utility pole failure*, Revised 4 August 2015 [p20].

²¹ Exhibit 55, Mr Colin MacKenzie, *Investigation of timber utility pole failure*, Revised 4 August 2015 [p20].

²² Exhibit 55: Mr Colin MacKenzie, *Investigation of timber utility pole failure*, 4 August 2015 [p20]; Transcript, 3 August 2015: Mr Colin MacKenzie [p730: line 12 – p732: line 45].

²³ Exhibit 55: Mr Colin MacKenzie, *Investigation of timber utility pole failure*, 4 August 2015 [p27]; Transcript, 3 August 2015: Colin Mackenzie [p733: line 8 – p734: line 21].

²⁴ Exhibit 55: Mr Colin MacKenzie, *Investigation of timber utility pole failure*, 4 August 2015 [p24].

Appendix C: Expert reports – hydrological reports

1. The Commission has received reports from three expert hydraulic engineers who considered the causes of the flooding of Grantham – Dr John Macintosh, Mr Stefan Szykarski and Dr David Newton. The Commission engaged Dr Macintosh and Mr Szykarski. Wagners engaged Dr Newton.
2. Dr Macintosh and Mr Szykarski gave evidence during the public hearings. Dr Newton was available but not required for cross-examination.

Evidence of Dr John Macintosh

3. Dr Macintosh is a Chartered Professional Engineer with over 35 years' experience in civil engineering including 29 years specialising in water engineering. Dr Macintosh holds a PhD in river hydraulics and was made an honorary fellow of Engineers Australia in 2015. Dr Macintosh is also the Director of Water Solutions Pty Ltd.¹

Scope of work performed by Dr Macintosh

4. Dr Macintosh provided three reports:
 - a) *Report to Grantham Floods Commission of Inquiry – Expert Hydrology Report 10 January 2011 – Circumstances and Contributing Factors, 11 August 2015 (Macintosh Main Report)*;²
 - b) *Report to the Grantham Floods Commission of Inquiry – Expert Hydrology Report 10 January 2011 – Circumstances and Contributing Factors Supplementary Material, 17 August 2015 (Macintosh First Supplementary Material)*;³ and
 - c) *Report to the Grantham Floods Commission of Inquiry – Expert Hydrology Report 10 January 2011 – Circumstances and Contributing Factors Supplementary Material No 2, 3 September 2015 (Macintosh Second Supplementary Material)*.⁴
5. The Macintosh Main Report was produced prior to Dr Macintosh's review of the expert reports produced by Mr Szykarski and Dr Newton. The opinions expressed by Dr Macintosh in his Main Report (and the modelling underlying that report) are independent of the opinions expressed by Mr Szykarski and Dr Newton about the flooding in Grantham.⁵
6. Dr Macintosh also provided a number of animations that depicted simulation outputs from the flood modelling scenarios presented in his reports.⁶ Those animations included the most likely scenario (described below), which was based upon what Dr Macintosh considered to be the most likely sequence of events at the Grantham quarry during the 10 January 2011 flood.
7. Dr Macintosh gave evidence over a number of days during the public hearings and was cross-examined at length about the opinions he expressed in his Main Report and First Supplementary Report.⁷ Dr Macintosh produced the Macintosh Second Supplementary Report to address further matters raised by some parties.

Terminology adopted by Dr Macintosh

8. In each of Dr Macintosh's reports and during the course of the hearings, Dr Macintosh referred to a number of key features around Grantham. Dr Macintosh produced a figure identifying Lockyer Creek and Sandy Creek, the railway embankment and bridge crossing of Sandy Creek, the Grantham quarry (including the western

embankment) and Gatton-Helidon Road⁸ and the areas he designated as eastern, central and western Grantham. A copy of that figure is reproduced below.



Figure C1: Grantham township locality map.

Source: Exhibit 144, Dr John Macintosh, *Report to Grantham Floods Commission of Inquiry – Expert Hydrology Report 10 January 2011 – Circumstances and Contributing Factors*, 11 August 2015 [Figure 1.2]

Key Information relied upon by Dr Macintosh

9. To assist Dr Macintosh, the Commission provided the following information:
 - a) eye-witness accounts of the flooding between Helidon and Grantham⁹;
 - b) Department of Natural Resources and Mines' (DNRM) stream gauging stations water height and flow records;
 - c) topographic data taken from LiDAR surveys taken from 1 to 22 August 2010 and from 10 February to 9 March 2011;
 - d) hydraulic modelling data for the study area and supporting flood study report¹⁰ prepared by SKM (now Jacobs) for the Lockyer Valley Regional Council (LVRC);
 - e) hydraulic modelling data for the study area and supporting report¹¹ prepared by Dr Phillip Jordan of SKM for the QFCOI;
 - f) additional peak flood level data not considered by previous flood investigations¹²;
 - g) expert geotechnical advice from Mr Starr in relation to soil horizons around the Grantham quarry¹³; and
 - h) a report prepared by Mr Szykarski in February 2015 for Nationwide News Pty Ltd entitled '*Grantham and Wagner quarry, Review of Flood Impact 10th January 2011 Flood Event*'¹⁴.
10. As part of his investigations, Dr Macintosh undertook a site inspection of the Grantham quarry, Grantham and its surrounds on 1 June 2015.¹⁵ Dr Macintosh circumnavigated the quarry pit and paid particular attention to the creek channel and adjacent overbank areas, the western side of the pit and existing levee banks, the location where the main breach occurred, the broken power pole on the western embankment and the state of the inside pit walls including a large scoured flow path in the south-eastern corner.¹⁶ He also undertook a detailed drive around the

streets of Grantham from the fuel station to Sorrensen Street, both sides of the railway embankment, Sandy Creek in between the railway and Gatton-Helidon Road, the entire length of Gatton-Helidon Road, and the road following Lockyer Creek downstream from Helidon to Carpendale via Kapernick's Bridge.¹⁷

Setup of Dr Macintosh's GFCOI Model

11. Dr Macintosh used computer models to assist him in assessing the flood in Grantham and, in particular, to assist him to identify factors that may have contributed to the flood and the extent of their contribution.
12. Two types of models are used for flood investigation purposes:¹⁸
 - a) a hydrology model which produces estimates of flood flow rates, usually from rainfall data; and
 - b) a hydraulic model which produces flood levels, flow depths, and velocities from flow rates.
13. For the purpose of modelling the flooding in Grantham, Dr Macintosh used a dynamic 2D hydraulic model (TUFLOW) and a hydrology model (RAFTS).¹⁹

The LVRC Models

14. As a starting point, Dr Macintosh used hydraulic modelling data for the study area prepared by SKM for the LVRC, which was developed to support SKM's flood study of the entire Lockyer Valley.²⁰ The LVRC flood study material included:²¹
 - a) a RAFTS hydrology model which provided estimates of catchment runoff flow hydrographs for the 10 January 2011 flood to a relatively high spatial resolution over the entire Lockyer Valley; and
 - b) a TUFLOW hydraulic model which provided estimates of floodwater surface levels and velocities (2D) for the 10 January 2011 flood to a 10 metres grid resolution over the entire Lockyer Valley.
15. The LVRC models included data files addressing:²²
 - a) the topography of the entire Lockyer Valley area (based on a 10 metres grid resolution) including hydraulic structures (such as bridges and culverts) and other topographic features (such as roads, gullies and levees);
 - b) the hydraulic roughness of the entire Lockyer Valley area;
 - c) the direct rainfall that fell over the entire Lockyer Valley area as relevant to the 10 January 2011 flood;
 - d) inflow hydrographs derived from rainfall for watercourses that included Lockyer Creek, Flagstone Creek, Ma Ma Creek, Monkey Waterholes Creek and Sandy Creek (which were the creek surrounding Grantham);
 - e) the change in the topographic features of the Grantham quarry during the flood, including the western embankment, and a system for modelling how the change occurred.

Suitability of the LVRC Models

16. Dr Macintosh considered that the LVRC models were not suited to the needs of the Commission without modification.²³ The LVRC models were designed for general flood management purposes rather than for an assessment of the flooding that occurred in Grantham. The models did not make use of the available actual records of creek flows but, rather, relied upon estimates of storm event flows derived from rainfall. Finally, the runtime for the LVRC models was quite long (close to 14 hours). In order to run the many simulations that would be required to assess the flooding in Grantham, Dr Macintosh considered he would need to reduce the runtime.

17. Dr Macintosh explained during the hearings²⁴ that SKM, in preparing the LVRC flood study, had applied design flow rates, rather than real conditions, with the primary point of interest being peak flood level and peak velocity and, to a secondary extent, how long it took for water levels to develop for the purposes of considering evacuation paths and planning. However, for this Commission, Dr Macintosh said that:

“...I wasn’t using the model in that way at all; I was using it to try to recreate exactly what happened. The challenge was getting the timing right for things. That took a lot ... longer than what I anticipated ... things change so rapidly. In a matter of minutes, people ... they’re up to their neck in water. Whereas, normally, [for] flood management work, if I was within 15 minutes, I would be happy but, in this instance, the minute was so important, so I had to drill down pretty tough and pretty solidly to get that sorted out.” (emphasis added)

18. Consequently, Dr Macintosh produced a sub-model from the LVRC modelling (termed the **GFCOI model**) that was better suited to modelling “exactly what happened” in Grantham.
19. Dr Macintosh’s model extended from the Helidon Gauging Station at the upstream boundary to a short distance downstream from the Gatton-Helidon road bridge crossing of Lockyer Creek (approximately five kilometres downstream from Grantham).²⁵ The extent of the modelled area in the GFCOI model is shown in figure C2 below.



Figure C2: Extent of the GFCOI hydraulic modelling area.

Source: Exhibit 144, *Dr John Macintosh, Report to Grantham Floods Commission of Inquiry – Expert Hydrology Report 10 January 2011 – Circumstances and Contributing Factors*, 11 August 2015 [p56: Figure 8.1]

Adaptation of the LVRC Models

20. Dr Macintosh analysed the GFCOI model and identified four areas where he needed to modify the existing data to better address the flooding in Grantham.

First modification – Inflow hydrographs for Lockyer Creek, Ma Ma and Flagstone Creek

21. A flood hydrograph is a graph that shows how flood flow rate or flood level at any particular location changes over time.²⁶ It is commonly plotted with the vertical axis being the level of flow or water level and the horizontal axis

being the time of discharge.²⁷ Hence, a flood flow hydrograph is a record of the flow rate in a watercourse over time.²⁸

22. Stream gauging stations automatically keep time-stamped stage water level records. A stream gauging station may also have a rating curve, which provides the relationship between the stage height as recorded at the gauging station and the flow in the watercourse. The information in the water level records can then be used to derive a flood flow hydrograph.²⁹
23. Dr Macintosh identified three stream gauging stations operated by DNRM, which were located on creeks used in the GFCOI model – Helidon (143203C), Flagstone Creek (143213C) and Ma Ma Creek (143213C).³⁰ Dr Macintosh did not identify any stream gauging stations on Sandy Creek and Monkey Waterholes and so for those creeks he retained the inflow hydrographs based on rainfall from the LVRC model.³¹
24. DNRM publishes the rating curve and stage records for the Helidon gauging station on its website. This data revealed a peak height of 13.88 million gegalitres and a peak flow rate of 3,640m³/s, which was reached at 3:10 pm on 10 January 2011. At one point, towards the peak of the flows, the Helidon gauging station failed and stopped recording.³² This occurred at the point when the water in the Lockyer Creek overtopped the Helidon gauging station.³³ There was therefore some uncertainty about the peak flood height at Helidon gauging station.



Figure C3: Hydrograph for Helidon stream gauging station on 10 January 2015.

Source: Exhibit 144, Dr John Macintosh, *Report to Grantham Floods Commission of Inquiry – Expert Hydrology Report 10 January 2011 – Circumstances and Contributing Factors*, 11 August 2015 [p59: Figure 8.2]

25. The peak height of 13.88 metres was derived from a survey conducted after the flood and this peak height was used to plot the graph by extrapolating the gradients of what was recorded before and after the gauge failed. In Dr Macintosh's opinion, DNRM's recreation of the stage heights was fairly accurate.³⁴
26. However, in Dr Macintosh's view, there remained considerable uncertainty about DNRM's rating curve (as distinct from the stage records).

27. Because the peak recorded level of the Lockyer Creek at Helidon on 10 January 2011 was 13.88 metres, some 10 metres higher than the historical gauged flow at 3.4 metres, a considerable amount of extrapolation was required to estimate the flow.³⁵ DNRM had indicated poor reliability in any measurement above 120m³/s or approximately three per cent of the total peak flow rate. Flow rates over 120m³/s were the product of calculation as opposed to direct measurement.³⁶
28. In addition, during the 2011 floods, there was significant erosion and deposition along sections of the creek as well as the knocking down and removal of a significant amount of vegetation at the location where the Helidon gauging station was located. This had the potential to affect the rating curve at the Helidon gauging station.³⁷
29. On the other hand, the rating curve for the Helidon gauging station used in the LVRC model was based upon the best assessment of actual rainfall including rainfall depths; the geometry of the waterway; and an assessment of the slope of the water associated with the discharge of water in Lockyer Creek. Dr Macintosh considered, initially, that the LVRC rating curve was based on a fairly robust set of data.³⁸
30. Dr Macintosh identified a number of differences between the LVRC and DNRM flow hydrographs:
 - a) the peak flow rate in LVRC flow hydrograph was 3,590m³/s which was slightly lower than the peak for the DNRM flow hydrograph of 3,640m³/s;³⁹
 - b) the LVRC flood study had modelled the peak being reached at 3:42 pm whereas DNRM modelled the peak being reached at 3:10 pm;⁴⁰
 - c) there was 30 per cent more volume shown in the LVRC flow hydrograph compared to the DNRM flow hydrograph;⁴¹ and
 - d) the shape of the LVRC hydrograph was different to the shape of the DNRM hydrograph in that the slopes of the rising and falling limbs were significantly gentler than indicated by the DNRM hydrograph.⁴²
31. Because of the differences between the LVRC hydrograph and the DNRM hydrograph, Dr Macintosh prepared his own rating curve and used it to prepare an inflow hydrograph for the Lockyer Creek at the Helidon Gauge. This inflow hydrograph is also plotted in figure C4 below.
32. Dr Macintosh's revised hydrograph had a peak flow rate of 4,600m³/s which is approximately 25 per cent greater than the DNRM peak.⁴³ Dr Macintosh's opinion was that his hydrograph better represented the flow in the Lockyer Creek as:
 - a) the flow volume in the revised hydrograph matched the flow volume associated with the LVRC hydrograph which was itself based on measured rainfall runoff rates;⁴⁴
 - b) the timing of the peak in the revised hydrograph matched DNRM's time of recorded water levels;⁴⁵ and
 - c) the shape of the revised hydrograph better matched DNRM's hydrograph on the rising limb.⁴⁶

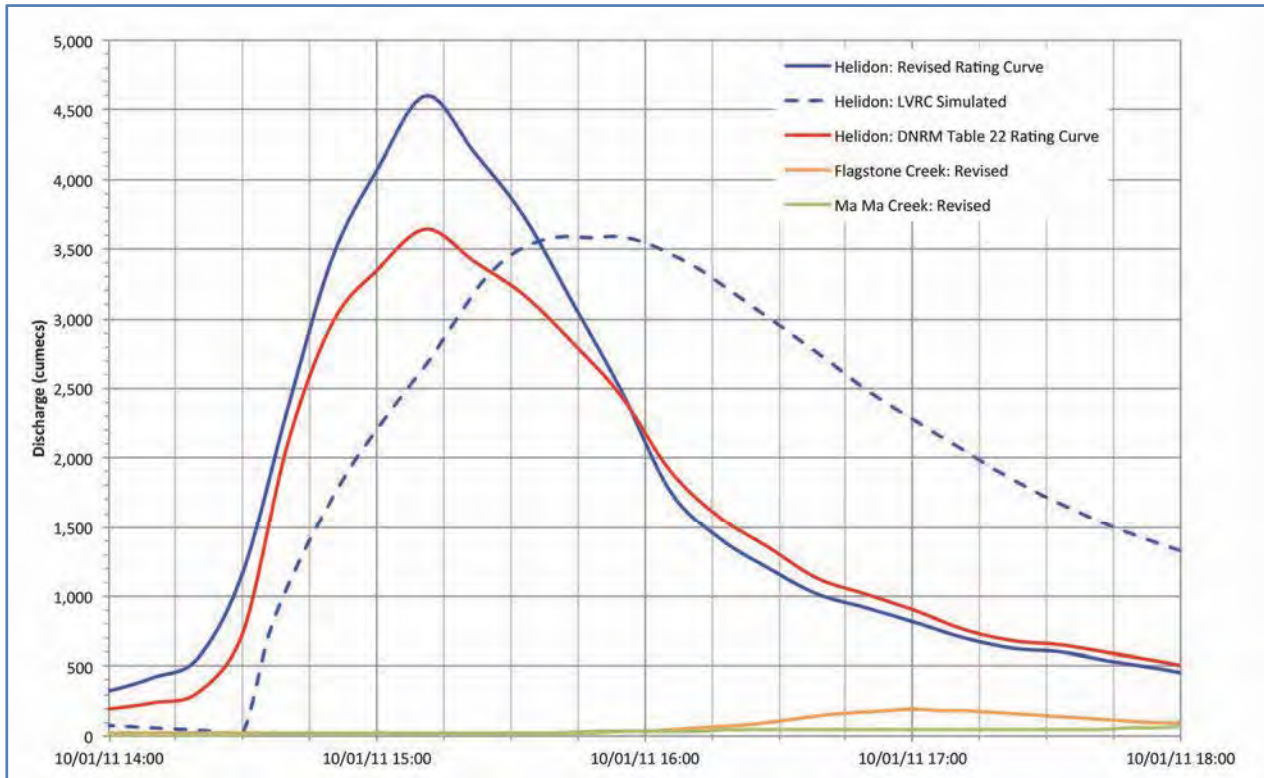

Figure C4: flood flow hydrographs at Helidon, Flagstone and Ma Ma Creeks using the DNRM rating curve, the LVRC simulated rating curve, and a revised rating curve.

Source: Exhibit 144, Dr John Macintosh, *Report to Grantham Floods Commission of Inquiry – Expert Hydrology Report 10 January 2011 – Circumstances and Contributing Factors*, 11 August 2015 [p63: Figure 8.7]

33. Consequently, Dr Macintosh modified the subset of the LVRC data files so as to replace the inflow hydrograph for the Lockyer Creek (Helidon gauge) with his revised inflow hydrograph referred to above.
34. DNRM also publishes rating curves for gauging stations in Flagstone Creek and Ma Ma Creek. Dr Macintosh considered that those rating curves accurately addressed the stage height and flow rates for those creeks. Using those published rating curves, Dr Macintosh prepared revised inflow hydrographs for Flagstone Creek and Ma Ma Creek based on the rating curves produced by DNRM.⁴⁷
35. Dr Macintosh altered the GFCOI model to replace the LVRC's inflow hydrographs for the Lockyer Creek, Flagstone Creek and Ma Ma Creek with his revised inflow hydrographs.⁴⁸ The final inflow hydrographs used by Dr Macintosh for these creeks are depicted in figure C5 below.

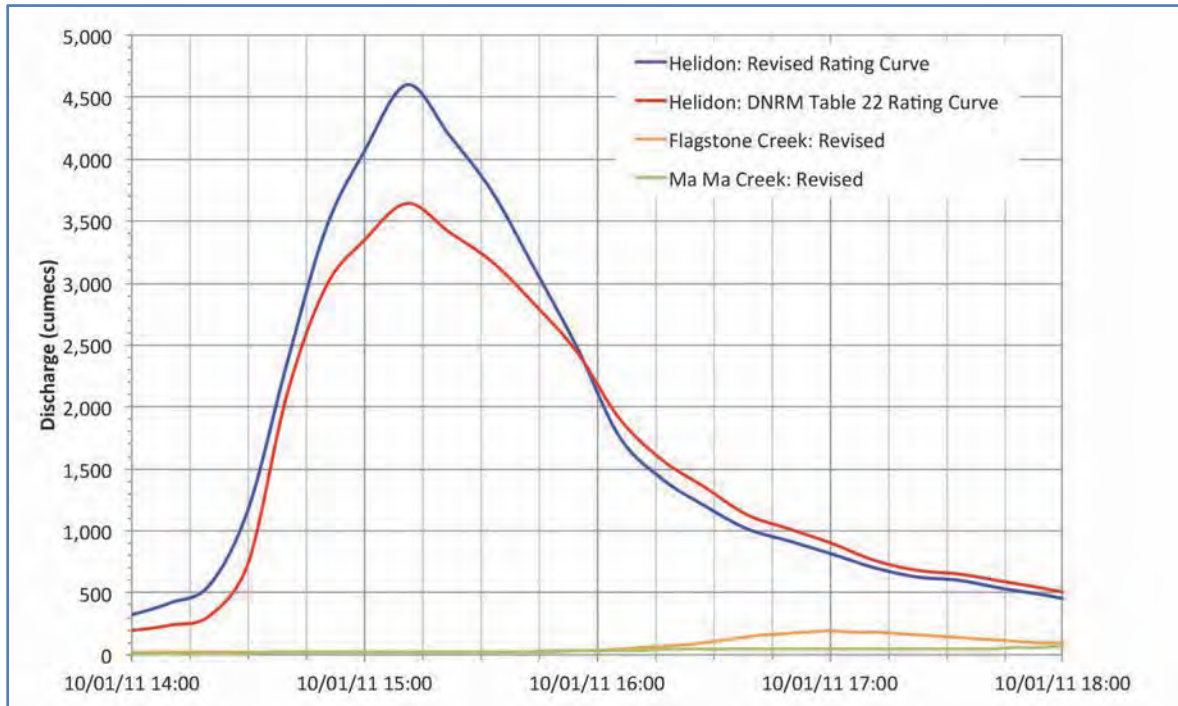

Figure C5: Final hydrographs used by Dr Macintosh.

Source: Exhibit 144, Dr John Macintosh, *Report to Grantham Floods Commission of Inquiry – Expert Hydrology Report 10 January 2011 – Circumstances and Contributing Factors*, 11 August 2015 [p24: Figure 1.6].

Second modification – hydraulic roughness data files

36. Hydraulic roughness is a parameter that represents the roughness of the surface over which water flows.⁴⁹ The greater the roughness, the slower and deeper the water flows. Hydraulic roughness and flow rate control the peak water levels during flooding.⁵⁰
37. Manning’s n is used in Dr Macintosh’s modelling as the stream roughness parameter.⁵¹ The higher the value assigned to Manning’s n , the rougher the surface and the slower the water flows over the surface⁵². A very smooth surface such as glass would have a value of 0.015.⁵³ Although recommendations are available for Manning’s n for different surfaces, the value chosen is a matter for the modeller.⁵⁴
38. The hydraulic roughness values that had been chosen for the LVRC models⁵⁵ were based on the inflow hydrographs that SKM had derived for the 10 January 2011 flood.⁵⁶ As Dr Macintosh had revised the inflow hydrographs for Lockyer Creek, Ma Ma Creek and Flagstone Creek, he considered it necessary to alter the hydraulic roughness coefficient to take into account his revised hydrographs.⁵⁷
39. Dr Macintosh’s revised calibration of the hydraulic roughness resulted in a change to the roughness coefficient for “farmland” from 0.05 to 0.06. The net effect of the recalibration was to produce an overall average difference in peak height of 0.0 metres between the simulated peak height and the surveyed peak levels.⁵⁸

Third modification - the topographic data files

40. The LVRC modelling relied upon the LiDAR surveys over the Helidon and Grantham area taken from 1 to 22 August 2010 and from 10 February to 9 March 2011 for its topographic data⁵⁹ and implemented in a 10 metre grid.

47. The effect of a 10 metre grid size is that each grid assumes an average height across each 10 square metres. If an item is only five metres in plan dimension, the model will not necessarily see it because it is too small.⁶⁸ Dr Macintosh identified that a local drainage feature running along Anzac Avenue was not addressed in the modelling because it was too small for the 10 metre grid size. Dr Macintosh modified the model to pick up the drainage feature using LiDAR data for the curb and channelling of the drainage feature.⁶⁹
48. After the change, the water modelled in the GFCOI model behaved in a way that better matched the photographs taken by Mr Lack prior to 4:05 pm.⁷⁰

C. The table drains along Lawlers Road

49. Mr Sippel gave evidence that on 10 January 2011 when he first got to Dinner Corner, “the water was running back through here and heading down the northern side of the train tracks and cutting across into Sandy Creek.”⁷¹
50. Dr Macintosh identified a mismatch between Mr Sippel’s recollection and the GFCOI model because the model, initially, did not show water flowing eastwards along Lawlers Road from floodwater that had accumulated around the railway underpass at Dinner Corner on Gatton-Helidon Road. The reason for this mismatch was that the model resolution was not fine enough to properly delineate the Lawlers Road table drains.
51. Dr Macintosh modified the topographic data files to include the Lawlers Road table drain as it runs east from Dinner Corner railway underpass. After this change, the GFCOI model produced results that reflected Mr Sippel’s observations.⁷²

Fourth modification – the Grantham quarry data files

52. Dr Macintosh carefully reviewed the data files associated with the Grantham quarry and the western embankment.

A. Topographic data relating to the pre-flood terrain

53. Based on Mr Starr’s opinion as to the line and level of the stockpiles, bunds and spoil surrounding the Grantham quarry,⁷³ Dr Macintosh was satisfied that the topographic data provided in the LVRC models for the features around the quarry pit was accurate.⁷⁴

B. Water level in the quarry pit lake immediately before the flood

54. The level of the water in the quarry pit on 10 January 2011 is important because it had a direct effect on the influence the Grantham quarry had on the flood flows and levels. On the one hand, the greater the water level in the quarry pit, the less spare capacity there was in the pit to absorb water before it overflowed.⁷⁵ Conversely, while the pit was filling, the volume of water filling the pit was removed from the flood thereby delaying and reducing in magnitude the flows downstream of the quarry.⁷⁶ In addition, the greater the water level in the quarry pit, the shorter the distance for the water to spill over the bunds into the quarry pit.⁷⁷
55. Dr Macintosh reviewed the eyewitness accounts but there were no direct observations of the quarry pit lake level immediately prior to the flood.⁷⁸ This left the actual level of the pit lake uncertain.
56. Dr Macintosh assessed the likely water level of the quarry pit by three steps.
57. First, Dr Macintosh compared the level of the quarry lake pit and the water level in adjacent Lockyer Creek using the LiDAR survey data taken in August 2010 and January 2011, and identified a relationship between lake level and

creek level. For each survey, the quarry pit lake level and the water level in the adjacent Lockyer Creek were the same – 114 metres AHD in August 2010, and 115.4 metres AHD in January 2011.⁷⁹

58. Second, Dr Macintosh calculated the water levels for the Lockyer Creek adjacent to the western side of the quarry based on the average flows for the 31 days preceding 10 January 2011 and the average for the 7 days preceding 10 January 2011. Dr Macintosh calculated those water levels using the flow rates at the Lockyer Creek for the Helidon gauging station over these periods.⁸⁰
59. Third, Dr Macintosh calculated the maximum pit lake level rise that could be caused by rainfall (assuming a total catchment for the pit lake of 16 hectares, a pit lake surface area of 10 hectares and 100 per cent rainfall run-off into the pit). Dr Macintosh made this calculation using daily rainfall records from the Helidon Post Office (Station 040096) to calculate the total rainfall for the 31 days preceding 10 January 2011 and the total rainfall for the 7 days preceding 10 January 2011.⁸¹
60. Dr Macintosh's assessment was that the highest average water level in the Lockyer Creek adjacent to the quarry pit was 117 metres AHD and the maximum possible further rainfall contribution into the catchment of the pit lake was 0.8 metres.⁸² Therefore, the highest reasonable estimate of the level of the pit lake as at 10 January 2011 was 117.8 metres AHD.
61. For the purposes of the GFCOI model, Dr Macintosh added an additional 2.2 metres of water, to lift the pit lake to 120 metres AHD. By doing this, Dr Macintosh further reduced the free flood storage capacity of the pit lake in the model and accounted for any other possible sources of volume contributions (such as, additional localised rainfall or further seepage inflows from Lockyer Creek).⁸³

C. Topographic data relating to the post-flood terrain

62. Dr Macintosh identified the differences between the pre-flood quarry terrain and the post-flood quarry terrain using the LiDAR data for August 2010 and February 2011. He prepared profiles of both the eastern and western bunds for the western embankment.⁸⁴

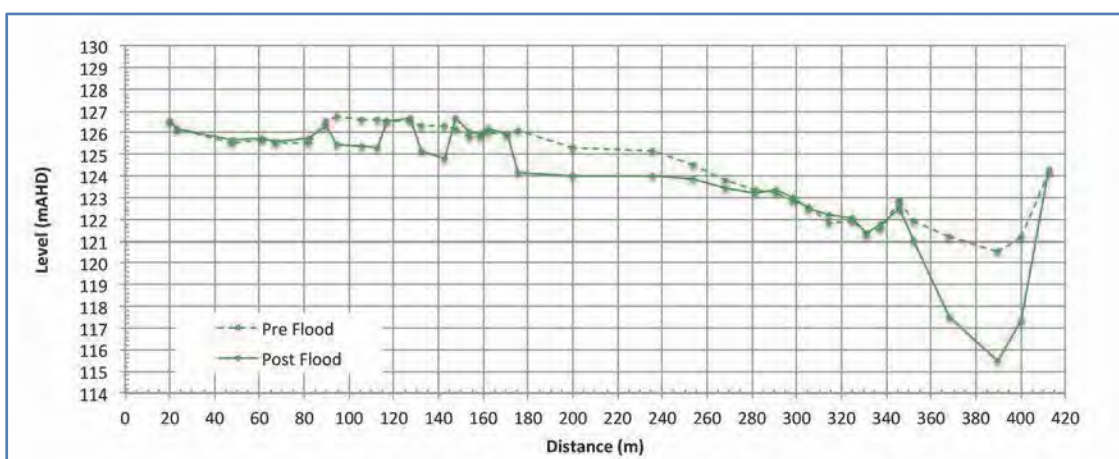

Figure C7: Western bund profiles for pre and post flood conditions.

Source: Exhibit 144, Dr John Macintosh, *Report to Grantham Floods Commission of Inquiry – Expert Hydrology Report 10 January 2011 – Circumstances and Contributing Factors*, 11 August 2015 [p71: Figure 8.17].

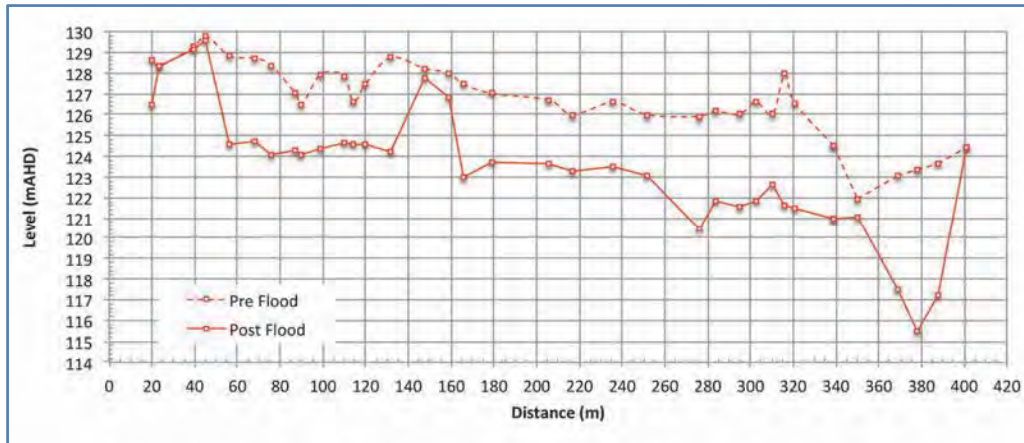

Figure C8: Eastern bund profiles for pre and post flood conditions.

Source: Exhibit 144, Dr John Macintosh, *Report to Grantham Floods Commission of Inquiry – Expert Hydrology Report 10 January 2011 – Circumstances and Contributing Factors*, 11 August 2015 [p71: Figure 8.18].

63. From these profiles, Dr Macintosh identified three breaches that occurred in the western embankment. Those breaches were formed when six distinct areas of erosion combined during the course of the 10 January 2011 flood.⁸⁵ Dr Macintosh prepared a table setting out the length of each of those breaches (Figure C9).

Location	Distance From (m)	Distance To (m)	Length of Breach (m)
Southern Breach	60	140	80
Central Breach	160	350	190
Main Breach	350	410	60
Total			330

Figure C9: location of the breaches in the western levee.

Source: Dr John Macintosh, *Report to Grantham Floods Commission of Inquiry – Expert Hydrology Report 10 January 2011 – Circumstances and Contributing Factors*, 11 August 2015 [p71: Table 8.2].

64. The main breach at the north-western corner of the Grantham quarry was the most significant. The main breach had the deepest drive through with the most amount of material removed from a single breach.⁸⁶

D. Mechanism for failure of the western embankment system

65. The LVRC models paid particular attention to the modelling of the western embankment failure.⁸⁷ The mechanism used in the LVRC models involved:
- an assessment of the before and after flood levels of the western embankment (based on pre and post flood LiDAR survey data from the topographic data files);
 - the identification of each of the areas where the western embankment breached (based on pre and post flood LiDAR survey data from the topographic data files);

- c) the use of trigger points at selected locations along the eastern and western bunds. The effect of those trigger points was to set a measure whereby the commencement of a breach would be initiated when the water height reached over the height of the trigger point; and
 - d) an assessment of the likely duration of each breach.
66. Dr Macintosh reviewed this mechanism and considered it could be adapted for the GFCOI model⁸⁸ in the way identified in figure C10 below.⁸⁹



Figure C10 – Quarry failure trigger level locations

Source: Exhibit 144, Dr John Macintosh, *Report to Grantham Floods Commission of Inquiry – Expert Hydrology Report 10 January 2011 – Circumstances and Contributing Factors*, 11 August 2015 [p26: Figure 1.8]

67. It should be noted that Dr Macintosh, at points in his report, refers to “levees”. However, he agreed when giving oral evidence that they should more correctly be referred to as bunds⁹⁰ and so that term is used in this Appendix. I also noted during the hearings that a range of terms were used to describe the embankments and that I would not be influenced by the terminology.⁹¹
68. Dr Macintosh modified the mechanism so as to set the six primary areas where he considered erosion occurred. Those areas are marked in Figure C10 as Levees 1 to 3 (on the western bund), Levees 4 and 5 (on the eastern bund) and main breach.⁹²
69. The trigger points for the collapse of the various parts of the bunds and the main breach used in the LVRC model were replaced by trigger points (marked “A”, “B” and “C” on this figure) chosen by Dr Macintosh.⁹³
70. As there were no direct observations of the time at which each breach was to commence,⁹⁴ the duration of each breach⁹⁵ or the manner in which the breaching occurred,⁹⁶ Dr Macintosh assessed the most likely parameters for these items. He also performed a sensitivity analysis to determine the effects of changes to these parameters.
71. There were two possible failure mechanisms. The first was top down erosion and the second was slip failure. If the bunds failed by top down erosion then the breaching would have occurred by water overtopping the bunds and the bunds then eroding away as the water flowed over them until the point where the water hit a relatively solid

surface, such as natural ground level. Conversely, if the bunds failed by slip failure then the bund would have failed structurally or, in other words, fallen away. For slip failure, the water would not have overtopped the bunds but rather would have seeped into the bunds and that seepage would have impacted on the strength of the bunds causing failure.⁹⁷

72. In Dr Macintosh's opinion, the most likely failure mechanism was top down erosion.⁹⁸ Dr Macintosh considered that the water rose at such a speed that before the bund became saturated and pieces of it fell away due to slip failure, the water would likely have risen over the top and commenced top down erosion.⁹⁹
73. Dr Macintosh used top down erosion as a parameter for the modelling of the most likely mechanism of failure and set the trigger points so as not to trigger until water overtopped the bunds.¹⁰⁰ Dr Macintosh also undertook sensitivity testing to determine whether using slip failure, instead of top down erosion, or changing the length of time over which erosion occurred, would have a material impact on the modelled results. It did not.¹⁰¹
74. Dr Macintosh assessed the likely timing of the breach by running his revised inflow hydrographs through the GFCOI model and identifying the time at which the flood waters reached the trigger heights, meaning the bunds had been overtopped. Because different parts of the bunds were at different heights, the triggers were also at different heights. This meant that top down erosion would commence in different areas at different times.¹⁰² Dr Macintosh considered that the likely commencement time for each of the breaches was 3:25 pm for the main breach, 3:45 pm for the southern breach (levees 1, 2 and 4 on Figure C10) and 3:56 pm for the central breach (levees 3 and 5).¹⁰³
75. The main breach was 7.5 metres deep and 11,740 metres³ of material was removed from it. The other breaches were about 3.4 metres deep and 19,140 metres³ was removed from them. Dr Macintosh's opinion, based on the depth of scour of each of the breaches and the amount of material removed during the flood,¹⁰⁴ was that the main breach likely took about five minutes to erode and the remaining breaches likely took about 14 minutes.¹⁰⁵
76. Based on this assessment, Dr Macintosh was satisfied that a duration of failure of 10 minutes was a reasonable estimation for his modelling as it was approximately midway between the likely main breach duration and the likely duration of the remaining breaches.¹⁰⁶

Corroboration of Dr Macintosh's GFCOI Model

77. While Dr Macintosh used a computer model to assist him in forming an opinion, he was conscious that the model was a schematisation of reality rather than the reality.¹⁰⁷ Consequently, there was a need for Dr Macintosh to corroborate the simulation outcomes from the model against eyewitness accounts¹⁰⁸ and peak survey levels.¹⁰⁹

Corroboration to eyewitness accounts

78. Dr Macintosh was provided with a number of eyewitness accounts concerning the flooding that occurred in Grantham on 10 January 2011. The experiences of these witnesses is summarised in Chapter 1, and their witness statements are available in full on the Commission's website at www.granthaminquiry.qld.gov.au.
79. Dr Macintosh initially selected the following eyewitness accounts to corroborate his model:¹¹⁰
 - a) Ms Frances Arndt;
 - b) Mr Bruce Marshall;
 - c) Mr Jonathan Sippel;

- d) Ms Helen Besley;
 - e) Mr Wayne Lack;
 - f) Mr Lance Richardson; and
 - g) Mr Anthony McIntosh.
80. Those eyewitnesses provided recollections of the flooding across 14 different locations ranging from upstream (west) of the quarry through to eastern Grantham (at Anzac Avenue).¹¹¹ The accounts also covered a number of significant events in the flood from the commencement of flooding upstream of the Grantham quarry (including Klucks Road, Castle Road and Carpendale Road), the commencement of flow into the Grantham quarry, the breakout of water from the hairpin bend in the creek adjacent to the Grantham quarry, the overtopping of Gatton-Helidon Road and the flood's rise and passage through Grantham.¹¹²
81. Dr Macintosh also checked his modelling against the accounts of Mr Harry Castle and Mr Reg Kluck who were upstream of the Grantham quarry.¹¹³
82. The results of that corroboration was as follows:
- a) The simulations were consistent¹¹⁴ with Ms Arndt's account as to the timing, source and direction of the breakout flow from Lockyer Creek to the south-west of 1348 Gatton-Helidon Road before 4:07 pm;¹¹⁵ the time, depth and rate of flooding inundation just east of 1420 Gatton-Helidon road between 4:07 pm and 4:09 pm;¹¹⁶ and the effect of the floodwaters on her and her husband's vehicle between 4:07 pm and 4:09 pm.¹¹⁷
 - b) The simulation was not consistent¹¹⁸ with Ms Arndt's recollection as to the height of the floodwaters at a tree that she and Mr Arndt clung to on Gatton-Helidon Road. But the simulation was consistent with the peak surveyed flood height at that same location.
 - c) The simulations were consistent¹¹⁹ with the descriptions of the time, depth and rate of flood inundation at 1420 Gatton-Helidon Road given by Mr Bruce Marshall in transcripts of 000 calls¹²⁰ he made on 10 January 2011.
 - d) The simulations were reasonably consistent¹²¹ with the descriptions provided by Mr Sippel of the timing of initial inflows of water in the quarry pit at both its north-western and south-western ends¹²², the timing and extent of inundation on Gatton-Helidon road to the north of the Grantham quarry¹²³ and the running of water down the northern side of the railway line from Dinner Corner towards Sandy Creek¹²⁴.
 - e) The simulations were consistent¹²⁵ with Ms Besley's descriptions, both in her witness statement¹²⁶ and in the transcript of a 000 call¹²⁷ she made, of the circumstances and sequence of overland flows near Quarry Access Road. The simulations were also consistent with Ms Besley's description of the effect of floodwaters on her husband's car.¹²⁸
 - f) The simulations were consistent¹²⁹ with Mr Lack's description of a rapid rise in flood levels and flood rates around eastern Grantham¹³⁰ and the time stamped photographs he took¹³¹ insofar as they depict the timing and depth of floodwaters.
 - g) The simulations were consistent¹³² with Mr Richardson's description in his witness statement of a significant rise of floodwaters at 12 Anzac Avenue between 4:15 pm and 4:53 pm¹³³ and the videos he took at that location.¹³⁴
 - h) The simulations were consistent with¹³⁵ the description provided by Mr McIntosh in a video¹³⁶ taken just before 3:09 pm on 10 January 2011 of the rapid rate of rise of floodwaters at 42 Klucks Road, a photograph provided by Mr McIntosh that was taken at 3:15 pm¹³⁷ on 10 January 2011 of the point at which the Lockyer

Creek was starting to break its banks at 42 Klucks Road, and a photograph provided by Mr McIntosh taken at 4:41 pm¹³⁸ on 10 January 2011 that showed the extent of inundation.

- i) The simulations were consistent¹³⁹ with Mr Castle's description and photographs¹⁴⁰ of peak flood levels at 86 Gatton-Helidon Road and over the length of Castle Road.
 - j) There was a slight inconsistency in relation to 67 Carpendale Road¹⁴¹ between the simulations and Mr McIntosh's¹⁴² description of the flood depth at that location. The inconsistency identified was a simulated flood level of 0.4 metres compared to an observed flood level of 0.0 metres.
83. Based on the close correlation between the eyewitness accounts and the modelled outcomes, Dr Macintosh concluded that the GFCOI model correctly simulated the timing and sequence of flooding through Grantham as described by eyewitnesses.¹⁴³

Corroboration to peak survey levels

84. In addition to eyewitness accounts, Dr Macintosh was also provided with peak water level data¹⁴⁴ from the LVRC, Mr Ian Rickuss MP and Mr Richard Cork, a Registered Surveyor.
85. Dr Macintosh compared the simulated peak water levels produced by the GFCOI model against this data.¹⁴⁵ There was a difference between the simulated peak flood heights from Klucks Road (upstream of the Grantham quarry) to eastern Grantham of between -0.5 metres to +0.4 metres, with an overall average difference of 0.0 metres.¹⁴⁶ But there was a significant difference between the simulated peak flood heights in the Carpendale area with the level at one survey mark being 0.9 metres in excess and the levels at four survey marks being 1.3 metres in excess.¹⁴⁷
86. There was a difference of between -0.17 metres to +0.07 metres between the simulated levels and the data points from Mr Rickuss, with an overall average difference of -0.04 metres.¹⁴⁸ There was a difference of between -0.29 metres and +0.31 metres, with an overall average of -0.06 metres,¹⁴⁹ when the simulated levels were compared to Mr Cork's surveyed levels.
87. Dr Macintosh formed the view that the significant difference in simulated peak flood heights in the Carpendale area did not affect the GFCOI model for three reasons. First, the slope of the land in that area meant that the water levels did not rise as rapidly as was indicated by the peak water level data provided.¹⁵⁰ Second, the data provided was not provided by a registered surveyor which meant that Dr Macintosh could not place any particular level of confidence in that data.¹⁵¹ Third, the error identified was removed from the area of interest.¹⁵²
88. Further, excluding the difference in the Carpendale area, the average difference was 0.0 metres. This close correlation was very important from Dr Macintosh's perspective and gave him confidence in the GFCOI model.¹⁵³ Accordingly, he considered that the GFCOI model was appropriately corroborated by the peak survey levels.

Dr Macintosh's assessment of the chronology of the January 2011 flood in Grantham

89. Based on the eyewitness accounts, Dr Macintosh understood that the sequence of flooding on 10 January 2011¹⁵⁴ had occurred in three stages.¹⁵⁵
90. First, there was inundation of the lower parts of central Grantham which occurred on account of water backing up into Sandy Creek from Lockyer Creek, in the manner consistent with the residents' usual experiences of flooding, as indicated in Figure C11.

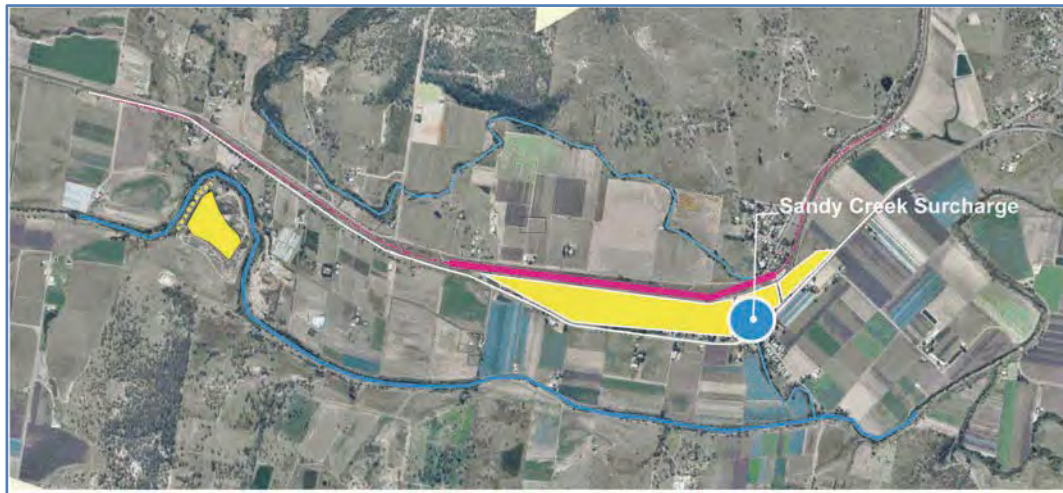

Figure C11: Simplified flooding locality, Sandy Creek Junction.
 Source: Exhibit 144, Dr John Macintosh, *Report to Grantham Floods Commission of Inquiry – Expert Hydrology Report 10 January 2011 – Circumstances and Contributing Factors*, 11 August 2015 [p21: Figure 1.3(a)]

- 91. Second, overland flows broke out from Lockyer Creek to the south-west of central Grantham and moved rapidly towards western Grantham, an occurrence that was unusual, as indicated in Figure C12.

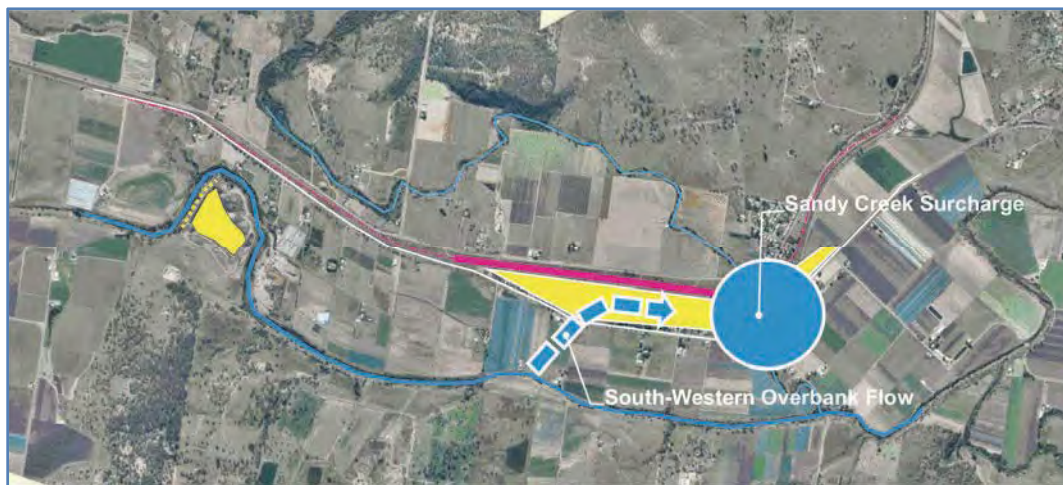

Figure C12: Simplified flooding locality, south-western overbank inundation.
 Source: Exhibit 144, Dr John Macintosh, *Report to Grantham Floods Commission of Inquiry – Expert Hydrology Report 10 January 2011 – Circumstances and Contributing Factors*, 11 August 2015 [p21: Figure 1.3(b)]

- 92. Third, within minutes of the overland flow reaching Grantham, a second front of fast moving overland flow from the west of Grantham (this had broken out from a creek near Quarry Access Road) then joined the south-western flows, as indicated in Figure C13.

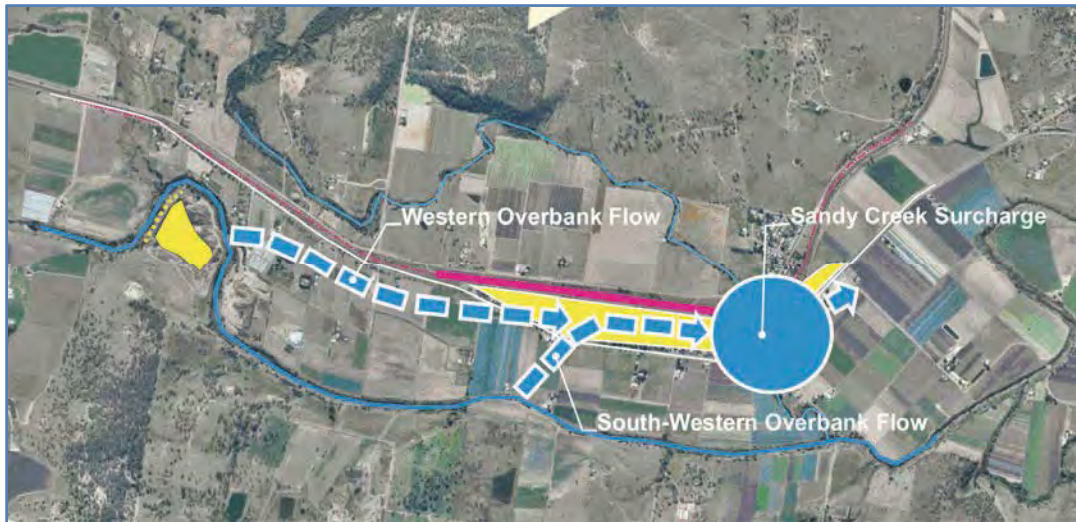

Figure C13: Simplified flooding locality, western overbank inundation.

Source: Exhibit 144, Dr John Macintosh, *Report to Grantham Floods Commission of Inquiry – Expert Hydrology Report 10 January 2011 – Circumstances and Contributing Factors*, 11 August 2015 [p21: Figure 1.3(c)]

93. At this point in time, the railway embankment was stopping all flow to the north, forcing any floodwater that would otherwise have travelled north, had the railway embankment not been present, to instead travel to the east, along with the remainder of the flows.
94. Dr Macintosh generated an animation from the GFCOI showing the progression of the flooding between 12 pm and 8 pm on 10 January 2011¹⁵⁶ based on his understanding. While Dr Macintosh produced a complete copy of that animation, he also provided three figures (together with a brief commentary) showing snap shots from that animation:¹⁵⁷
- a) the Grantham quarry and upstream, between 2:45 pm and 4:20 pm;
 - b) central Grantham, between 3:25 pm and 4:30 pm; and
 - c) western Grantham, between 3:25 pm and 5:00 pm.

Copies of those figures are reproduced in figures C14 to C22 below.





Image	Time and Commentary
	<p>(a) 2:45pm</p> <ul style="list-style-type: none"> Flow within Lockyer Creek.
	<p>(b) 3:00pm</p> <ul style="list-style-type: none"> Flow within Lockyer Creek at bank full at the upstream.
	<p>(c) 3:15pm</p> <ul style="list-style-type: none"> Lockyer Creek breaking out of the waterway upstream from the quarry.
	<p>(d) 3:20pm</p> <ul style="list-style-type: none"> Flow from Lockyer Creek spilling into the quarry (commenced in the minutes prior). Note inflow occurring in both the north-western and south-eastern quadrants of the quarry. "Oval" area upstream of quarry receiving inflow.

Figure 14: Chronology of inundation, quarry and upstream 2.45 pm to 3.20 pm

Source: Exhibit 144, Dr John Macintosh, *Report to Grantham Floods Commission of Inquiry – Expert Hydrology Report 10 January 2011 – Circumstances and Contributing Factors*, 11 August 2015 [p81: Figure 9.1 a to d]



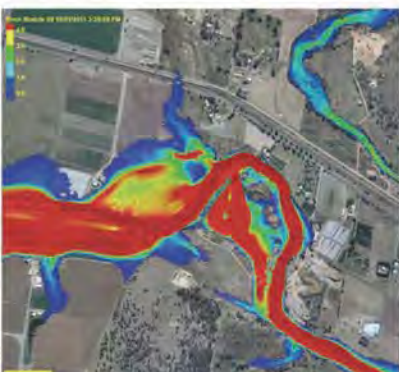

Image	Time and Commentary
	<p>(e) 3:25pm</p> <ul style="list-style-type: none"> • Lockyer Creek has broken out upstream from the quarry. • “Oval” area upstream of quarry receiving inflow.
	<p>(f) 3:30pm</p> <ul style="list-style-type: none"> • A marked increase in intensity of spill into the quarry associated with further erosion of the Main Breach. • Flow depths and intensities upstream from quarry continue to increase. • The Main Breach in the Western Levee has initiated.
	<p>(g) 3:35pm</p> <ul style="list-style-type: none"> • Commencement of outflow from the quarry through the south-eastern quadrant. • Breakout from Lockyer Creek at Quarry Access Road causeway commences with a rapid rise in local water levels. • Flow depths and intensities upstream from the quarry continue to increase.
	<p>(h) 3:40</p> <ul style="list-style-type: none"> • Failure of Main Breach complete. • Breakout from Lockyer Creek at Quarry Access Road causeway continues with a rapid rise in local water levels. • Full breaking out of the right overbank flow path to the south of the quarry. • Flow depths and intensities upstream from the quarry continue to increase.

Figure C15: Chronology of inundation, quarry and upstream 3.25 pm to 3.40 pm

Source: Exhibit 144, Dr John Macintosh, *Report to Grantham Floods Commission of Inquiry – Expert Hydrology Report 10 January 2011 – Circumstances and Contributing Factors*, 11 August 2015 [p82: Figure 9.1 e to h]

Image	Time and Commentary
	<p>(i) 3:45pm</p> <ul style="list-style-type: none"> • Breakout from Lockyer Creek at Quarry Access Road causeway continues with a rapid rise in local water levels. • Flow intensities starting to increase at the Quarry Access Road causeway breakout. • Full breaking out of the right overbank flow path to the south of the quarry. • Flow depths and intensities continue to increase throughout
	<p>(j) 3:50pm</p> <ul style="list-style-type: none"> • Initiation of erosion of the bunds in the Western Levee (other than in the area of the Main Breach). • Depth of water at 1615 Gatton-Helidon Road exceeds 0.3m (my estimated time of closure for evacuation purposes). • Flows commence along the Western Overbank flow path.
	<p>(k) 4:05pm</p> <ul style="list-style-type: none"> • Western Levee erosion now almost fully complete. • Floodplain upstream from quarry extends clear across to Gatton-Helidon Road.
	<p>(l) 4:20pm</p> <ul style="list-style-type: none"> • Flood levels close to peak.

Figure C16: Chronology of inundation, quarry and upstream 3.45 pm to 4.20 pm

Source: Exhibit 144, Dr John Macintosh, *Report to Grantham Floods Commission of Inquiry – Expert Hydrology Report 10 January 2011 – Circumstances and Contributing Factors*, 11 August 2015 [p83: Figure 9.1 I to l]

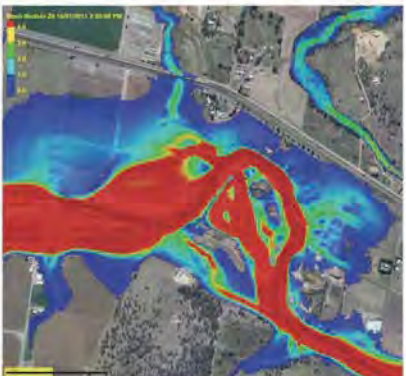
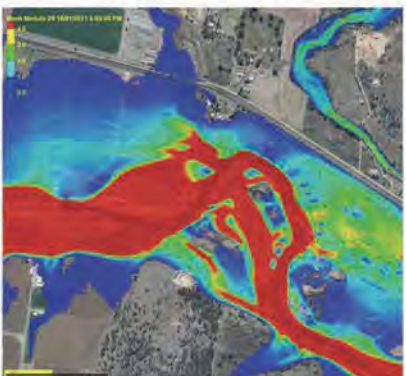
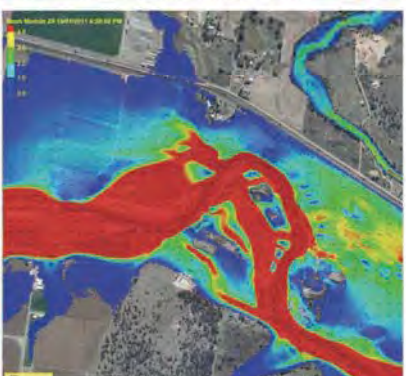

Image	Time and Commentary
	<p>(a) 3:25pm</p> <ul style="list-style-type: none"> Flow depths begin to increase in Lockyer Creek and commence backing up in local drainage paths.
	<p>(b) 3:40pm</p> <ul style="list-style-type: none"> Flow depths continue to increase. Flow break out commences at the start of the South-Western Overbank path. Note that erosion of the Main Breach has already been initiated at the quarry.
	<p>(c) 3:55pm</p> <ul style="list-style-type: none"> Flow depths continue to increase. South-Western Overbank flows have reached the Gatton-Helidon Road. Western Overbank flows have commenced moving towards Grantham from their start at the quarry. Note that Western Levee erosion now almost fully complete.
	<p>(d) 4:00pm</p> <ul style="list-style-type: none"> South-Western Overbank flow depths have exceeded 0.3m (my estimated time of closure for evacuation purposes). South-Western Overbank have commenced flowing through Western Grantham. Western Overbank flows have continued moving towards Grantham.

Figure C17: Chronology of inundation, western Grantham 3.25 pm to 3.40 pm

Source: Exhibit 144, Dr John Macintosh, *Report to Grantham Floods Commission of Inquiry – Expert Hydrology Report 10 January 2011 – Circumstances and Contributing Factors*, 11 August 2015 [p84: Figure 9.2 a to d]

Image	Time and Commentary
	<p>(e) 4:05pm</p> <ul style="list-style-type: none"> • South-Western Overbank flows have further inundated Western Grantham. • Western Overbank flows now nearing Western Grantham.
	<p>(f) 4:10pm</p> <ul style="list-style-type: none"> • Western Overbank flows have now joined with the South-Western Overbank flows, and continue to travel through Western Grantham.
	<p>(g) 4:15pm</p> <ul style="list-style-type: none"> • Western and South-Western Overbank flow continue to travel through Western Grantham.
	<p>(h) 4:20</p> <ul style="list-style-type: none"> • Floodwater has commenced overtopping the railway embankment.

Figure C18: Chronology of inundation, western Grantham 4.05 pm to 4.20 pm

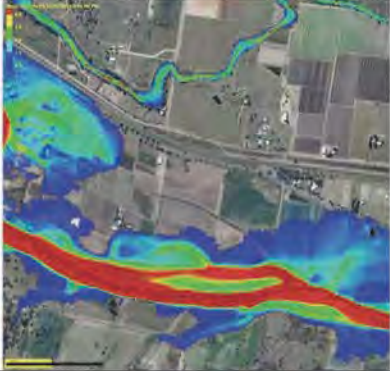
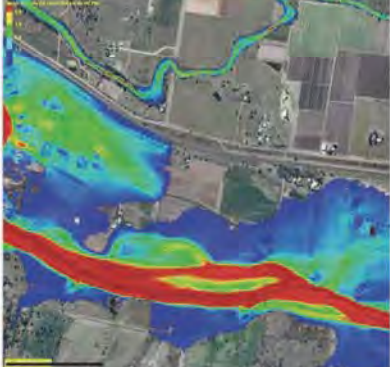
Source: Exhibit 144, Dr John Macintosh, *Report to Grantham Floods Commission of Inquiry – Expert Hydrology Report 10 January 2011 – Circumstances and Contributing Factors*, 11 August 2015 [p85: Figure 9.2 e to h]

Image	Time and Commentary
	<p>(i) 4:25pm</p> <ul style="list-style-type: none"> Flood flow intensities in Western Grantham appear to be around their peak.
	<p>(j) 4:30pm</p> <ul style="list-style-type: none"> Flood flow intensities in western Grantham appear to be around their peak.
	<p>(k) 4:45pm</p> <ul style="list-style-type: none"> Flood depths appear to be close to their peaks
	<p>(l) 5:00pm</p> <ul style="list-style-type: none"> Flood depths appear to be close to their peaks

Figure C19: Chronology of inundation, western Grantham 4.25 pm to 5.00 pm

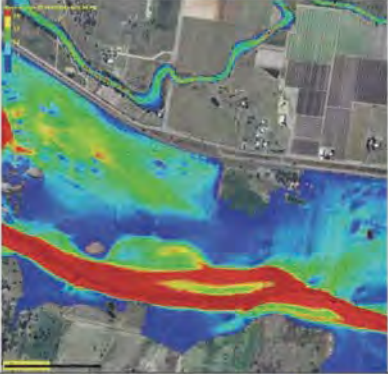
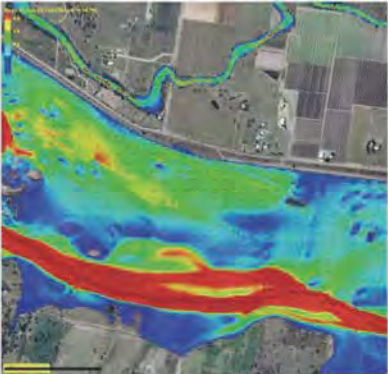
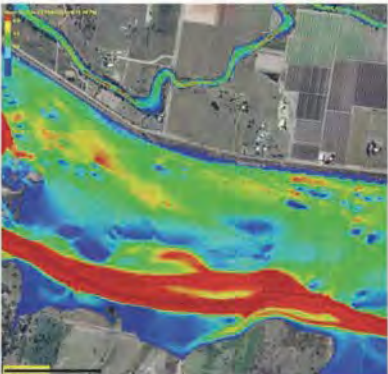
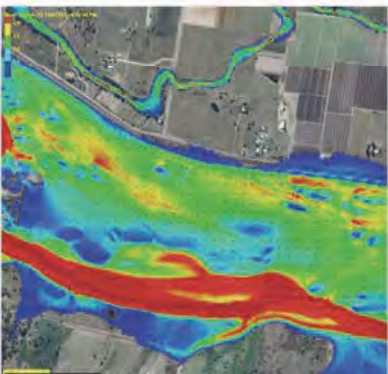
Source: Exhibit 144, Dr John Macintosh, *Report to Grantham Floods Commission of Inquiry – Expert Hydrology Report 10 January 2011 – Circumstances and Contributing Factors*, 11 August 2015 [p86: Figure 9.2 i to l]



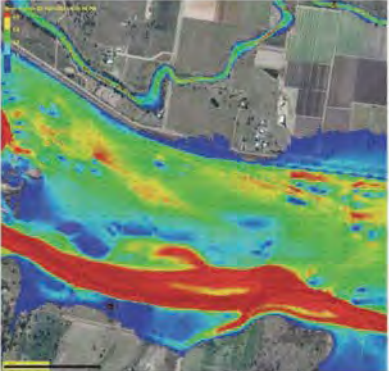
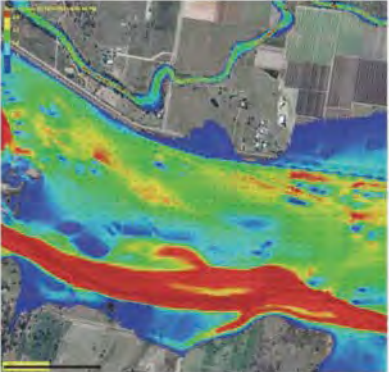
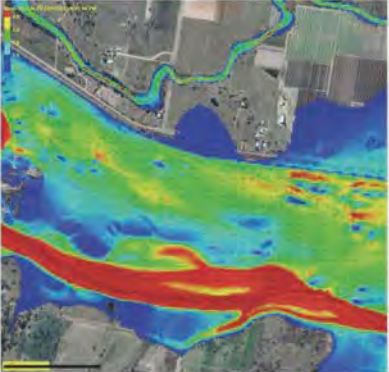
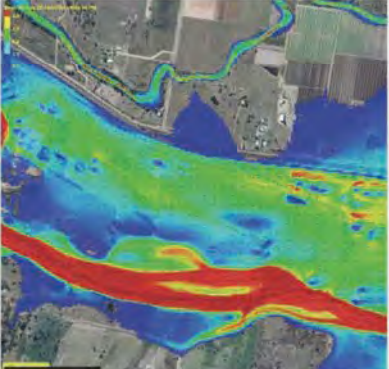

Image	Time and Commentary
	<p>(a) 3:25pm</p> <ul style="list-style-type: none"> Sandy Creek has just surcharged and commenced inundating Central Grantham.
	<p>(b) 3:40pm</p> <ul style="list-style-type: none"> Sandy Creek surcharge continues inundating Central Grantham. Note that erosion of the Main Breach at the quarry has already been initiated.
	<p>(c) 3:55pm</p> <ul style="list-style-type: none"> Lockyer Creek has broken its banks with inundating flows rapidly approaching Grantham from the South-Western Overbank flow path. The Gatton-Helidon bridge over Sandy Creek has now been overtopped and within 1 minute the depth will exceed 0.3m (my estimated time of closure for evacuation purposes). This will result in closure of the last evacuation route for Western Grantham. Note that erosion of the Main Breach has completed. Note that erosion of the bunds in the Western Levee (other than in the area of the Main Breach) have commenced.
	<p>(d) 4:00pm</p> <ul style="list-style-type: none"> Floodwater from Lockyer Creek over the South-Western Overbank flow path has overtopped the Gatton-Helidon Road in Western Grantham, but these floodwaters have not yet reached the road within Central Grantham. Sandy Creek surcharge is continuing to inundate Central Grantham, but not as quickly as it is occurring in Western Grantham.

Figure C20: Chronology of inundation, central Grantham 3.25 pm to 3.40 pm

Source: Exhibit 144, Dr John Macintosh, *Report to Grantham Floods Commission of Inquiry – Expert Hydrology Report 10 January 2011 – Circumstances and Contributing Factors*, 11 August 2015 [p87: Figure 9.3 a to d]

Image	Time and Commentary
	<p>(e) 4:05pm</p> <ul style="list-style-type: none"> Floodwater from the Western Overbank flow continues to encroach on Grantham at speed, while Sandy Creek surcharge continues to rise.
	<p>(f) 4:10pm</p> <ul style="list-style-type: none"> The remaining properties in the vicinity of Nicholls Street become inundated.
	<p>(g) 4:15pm</p> <ul style="list-style-type: none"> Flood inflows under the rail bridge significantly intensify as the fast moving floodwater from the South-Western Overbank flows now reach this location. Floodwater from the west continues through Central Grantham.
	<p>(h) 4:20</p> <ul style="list-style-type: none"> Floodwater has commenced overtopping the railway embankment. Flood inflows under the rail bridge continue to intensify as the fast moving floodwater from the South-Western Overbank flows combine with those from the Western Overbank flows. Flow intensities have increased in Eastern Grantham.

Figure C21: Chronology of inundation, central Grantham 4.05 pm to 4.20 pm

Source: Exhibit 144, Dr John Macintosh, *Report to Grantham Floods Commission of Inquiry – Expert Hydrology Report 10 January 2011 – Circumstances and Contributing Factors*, 11 August 2015 [p88: Figure 9.3 e to h]

Image	Time and Commentary
	<p>(i) 4:25pm</p> <ul style="list-style-type: none"> • Floodwater continues to overtop the railway embankment. • Inflows under the rail bridge continue at high intensity. • Flow intensities have increased in Eastern Grantham.
	<p>(j) 4:30pm</p> <ul style="list-style-type: none"> • Floodwater continues to overtop the railway embankment. • Inflows under the rail bridge continue at high intensity. • Flow intensities continue to increase within Eastern Grantham.
	<p>(k) 4:45pm</p> <ul style="list-style-type: none"> • Flows at the rail bridge location reverse in consequence of rail embankment overflows. • Flow intensities in Eastern Grantham significantly increase in conjunction with the rail bridge flow reversal. • Flood flow intensities in Central and Eastern Grantham around their peak.
	<p>(l) 5:00pm</p> <ul style="list-style-type: none"> • Flood flow intensities in Central and Eastern Grantham around their peak.

Figure C22: Chronology of inundation, eastern Grantham 4.25 pm to 5.00 pm

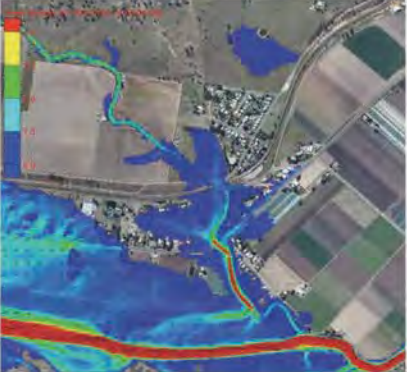
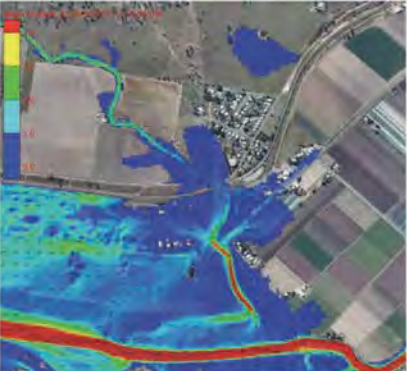
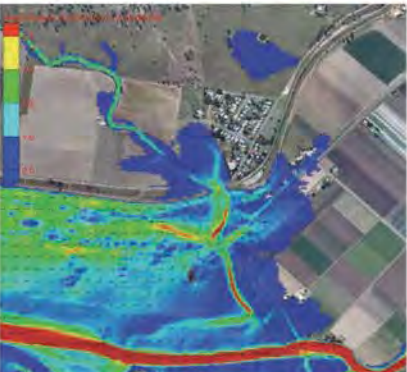
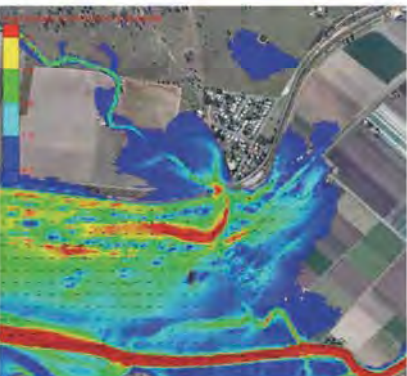
Source: Exhibit 144, Dr John Macintosh, *Report to Grantham Floods Commission of Inquiry – Expert Hydrology Report 10 January 2011 – Circumstances and Contributing Factors*, 11 August 2015 [p89: Figure 9.3 i to l]

Dr Macintosh's assessment of the impact of the Grantham quarry

Grantham quarry model scenarios

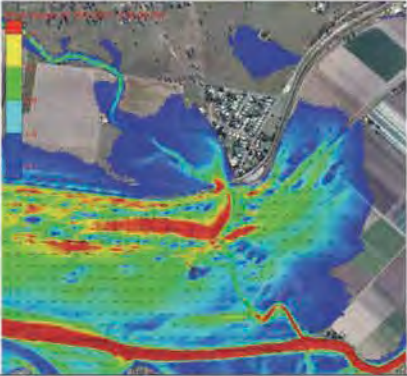
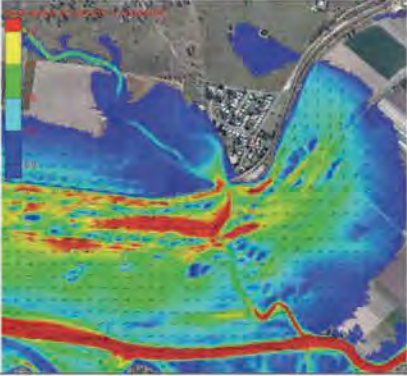
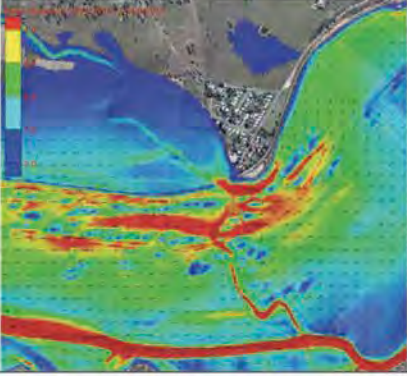
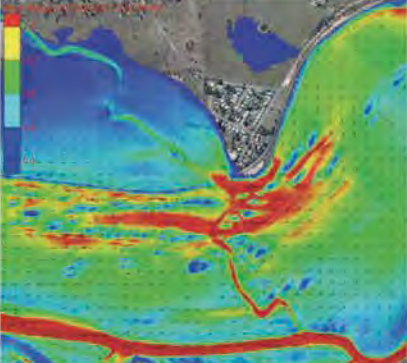
95. In order to assess the impact of the Grantham quarry, Dr Macintosh modelled a number of different scenarios:
- a most likely scenario;
 - a no quarry scenario;
 - a no levee scenario;
 - a no Grantham sand plant scenario;
 - a worst case (greatest delay) scenario;
 - a worst case (greatest drop) scenario;
 - a most likely (greatest delay) scenario; and
 - a most likely (worst case delay) scenario.
96. The scenarios were also designed to test the four items of uncertainty:
- the level of the quarry pit lake as at 10 January 2011;
 - the time at which the breaching of the western embankment commenced;
 - the duration of the breaching of the western embankment; and
 - the manner in which the breaching occurred.
97. Notwithstanding Dr Macintosh's view as to what he thought were the appropriate parameters for these four items based on what was most likely to have occurred, he also ran alternative scenarios to test and understand the significance, if any, of variations to these four items.
98. For each scenario, Dr Macintosh prepared an animation depicting the progression of the flooding between 12 pm and 8 pm.

Most likely scenario

99. Dr Macintosh's "most likely scenario" was modelled based on his view as to what was most likely to have occurred at the Grantham quarry. In this scenario:
- the pit lake level at 120 metres AHD;
 - the method of failure was progressive, top down erosion where the eastern and western bunds were overtopped prior to initiation of breaching;
 - the duration of failure of each breach was 10 minutes; and
 - the time at which each breach commenced was:
 - 3:25 pm for the main breach;
 - 3:45 pm for the southern breach (levees 1, 2 and 4 on Figure C10); and
 - 3:56 pm for the central breach (levees 3 and 5 on Figure C10).

100. The most likely scenario was corroborated by eyewitness accounts and peak flood levels as summarised in section “Corroboration of Dr Macintosh’s GFCOI Model” above.

No quarry scenario

101. Dr Macintosh modelled a “no quarry” scenario with the Grantham quarry removed. The quarry pit, embankments, bunds and associated surface disturbances (such as spoil piles, stockpiles and roads associated with quarry operations) were replaced with the natural terrain as it was before the existence of the quarry. This natural terrain was determined by Mr Starr as shown in Figure A2 in Appendix A.
102. The natural surface along the creek bank on the western side of the pit sloped to a low point at the north-western corner (the area where the main breach later developed). The topography was slightly depressed running from this low point to what appeared to Dr Macintosh to be a remnant of an old watercourse in the southeast corner of the quarry area.¹⁵⁸
103. Dr Macintosh’s opinion was that, prior to the construction of the Grantham quarry, the primary direction of any breakout from the Lockyer Creek into the area inside the u-shaped bend would be from the low point in the north-western corner to the south-eastern quadrant. The flood path was depicted by Dr Macintosh on an aerial photograph of the quarry area taken in 1982 as indicated in figure C23 below:



Figure C23: Quarry area in 1982 overlaid with flood path

Source: Exhibit 144, Dr John Macintosh, *Report to Grantham Floods Commission of Inquiry – Expert Hydrology Report 10 January 2011 – Circumstances and Contributing Factors*, 11 August 2015 [p90: Figure 10.1]

No Grantham sand plant scenario

104. The no Grantham sand plant scenario, referred to by Dr Macintosh as the “no quarry operations” scenario, modelled what would occur if both the Grantham quarry and the material processing, storage and batching plant were removed and the topography for both the quarry area and the plant area were replaced with the natural terrain.¹⁵⁹
105. Dr Macintosh used the pre-quarry surface as assessed by Mr Starr for each of the quarry area and the plant area.¹⁶⁰

No levee scenario

106. Dr Macintosh modelled the “no levee” scenario by altering the topography for the Grantham quarry so as to remove the bunds and spoil piles surrounding the quarry, while leaving the quarry pit itself in place.¹⁶¹

Worst case scenarios

107. Dr Macintosh modelled two “worst case” scenarios. These scenarios were not based on reality and were not plausible.¹⁶² They were designed to test, within the confines of the topography and the floodwater coming through that topography, the biggest possible effect that Dr Macintosh could achieve by manipulating the quarry and the bunds to test the physical limits of the system.¹⁶³ In particular, Dr Macintosh substantially raised the height of the western embankment for these scenarios so as to create a fictional six metre high wall.¹⁶⁴
108. For these “worst case” scenarios, Dr Macintosh:¹⁶⁵
- a) set the pit lake level at 122 metres AHD, which was the maximum storage capacity for the quarry pit;
 - b) changed the method of failure of the western embankment so that the entire embankment would fail simultaneously;
 - c) set the duration of failure to be near instantaneous over a period of five seconds; and
 - d) increased the height of the entire western embankment to above peak flood levels.
109. These modifications were designed to maximise the volume of any surging floodwater from the area near 25 Quarry Access Road towards Grantham, maximise the differential in water level between the creek adjacent to the western embankment and the quarry pit lake and minimise the capacity of the quarry pit to absorb inflowing water from a breach to the western embankment.¹⁶⁶
110. Dr Macintosh prepared a profile through the eastern bund and plotted on that profile the ground level of the eastern bund pre-flood (as determined by Mr Starr) together with the changes he made to lift that level to above peak flood heights.¹⁶⁷ That profile is Figure C24 below.
111. The dashed red line on Figure C24 represented the pre-flood ground level with the blue lines representing the changed levels for the western embankment.¹⁶⁸ As demonstrated by the blue lines, Dr Macintosh lifted the entire length of the western embankment so that it was even for the full length.¹⁶⁹ In some places, Dr Macintosh had lifted the height of the western embankment more than six metres above the actual pre-flood height of the bunds as had been determined by Mr Starr.¹⁷⁰
112. By doing this, Dr Macintosh was seeking to simulate an impermeable object that was too high to be overtopped, thereby preventing water entering the quarry pit over the western embankment until the commencement of failure.¹⁷¹ For this model, Dr Macintosh was simulating instantaneous failure rather than top-down erosion.

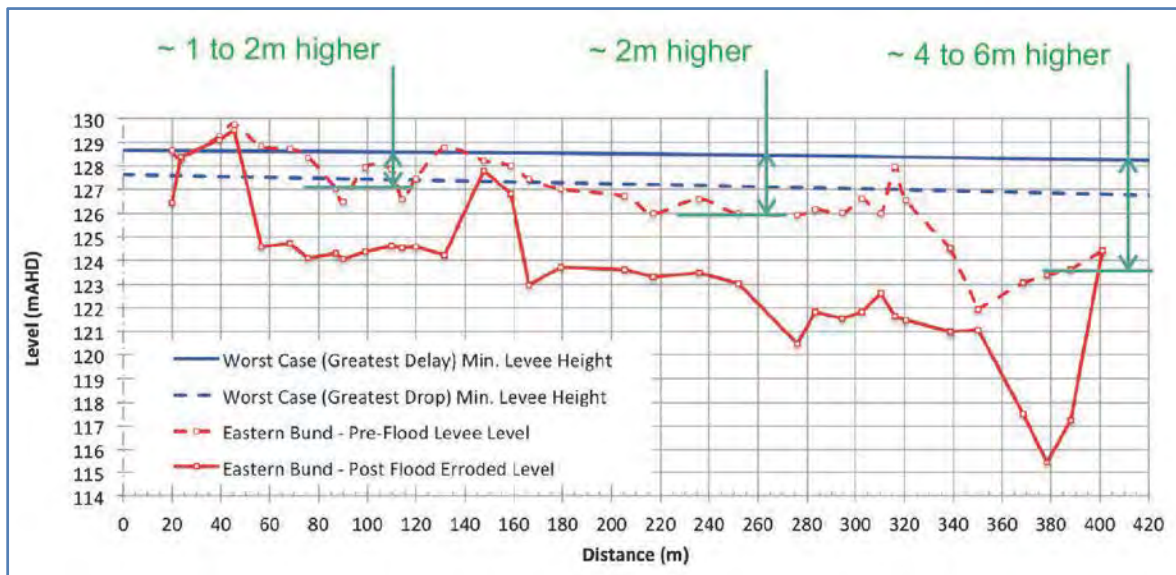

Figure C24: Profile through eastern bund with worst case bunds overlaid

Source: Exhibit 144, Dr John Macintosh, *Report to Grantham Floods Commission of Inquiry – Expert Hydrology Report 10 January 2011 – Circumstances and Contributing Factors*, 11 August 2015 [p109: Figure 10.15]

113. Dr Macintosh ran a range of trigger heights through the model and observed the impact on the time of initiation of failure, the upstream water levels and the drop between the Lockyer Creek and the quarry pit¹⁷². The results of that analysis produced two variations of the worst case scenarios:¹⁷³
- a worst case (greatest delay) scenario – a scenario which produced the greatest delay until initiation of failure (4:16 pm), with a trigger level of 126.4 metres AHD; and
 - a worst case (greatest drop) scenario – a scenario which produced the greatest Lockyer Creek to quarry pit lake drop (of 3.7 metres), with a trigger level of 124.5 metres AHD.
114. However, neither of these scenarios was realistic because of the changes that Dr Macintosh had made to the physical reality of the quarry. Dr Macintosh made clear that it was not plausible that:¹⁷⁴
- the initial pit lake level was 122 metres AHD, as it would have required a further 2 metres of rainfall to have fallen over the quarry area on or within a few days prior to 10 January 2011;
 - the western embankment failed within five seconds including to the full extent of the erosion to the main breach. The extent of the material removed was more consistent with a 10 minute breach;
 - the height of the western embankment was as high as that simulated in the worst case scenarios or collapsed in unison. Those heights were much higher (in some areas four to six metres higher) than was in fact the case. It was also unrealistic to think the bunds failed in unison because it depended upon them all being the same height, and constructed with the same geometry and material, which was inconsistent with Mr Starr’s opinion.

Most likely (delay) scenarios

115. Dr Macintosh prepared two variations of the most likely scenario in which the failure of the bunds happened over five seconds but the commencement was delayed until:¹⁷⁵
- water heights reached 126.4 metres AHD, which was the most likely (greatest delay) scenario; and
 - 4:16 pm, which was the most likely (worst case delay) scenario.

Assessment of the Grantham quarry scenarios

116. Dr Macintosh assessed the different scenarios by comparing simulated flood flow hydrographs, at locations downstream of the Grantham quarry (**downstream reporting locations**) and depth and flow intensity hydrographs at a number of locations downstream of the Grantham quarry (**depth and flow intensity locations**).¹⁷⁶
117. There were three downstream reporting locations (Lockyer Creek, western overbank and south-western overbank)¹⁷⁷ that are marked in Figure C25 below.

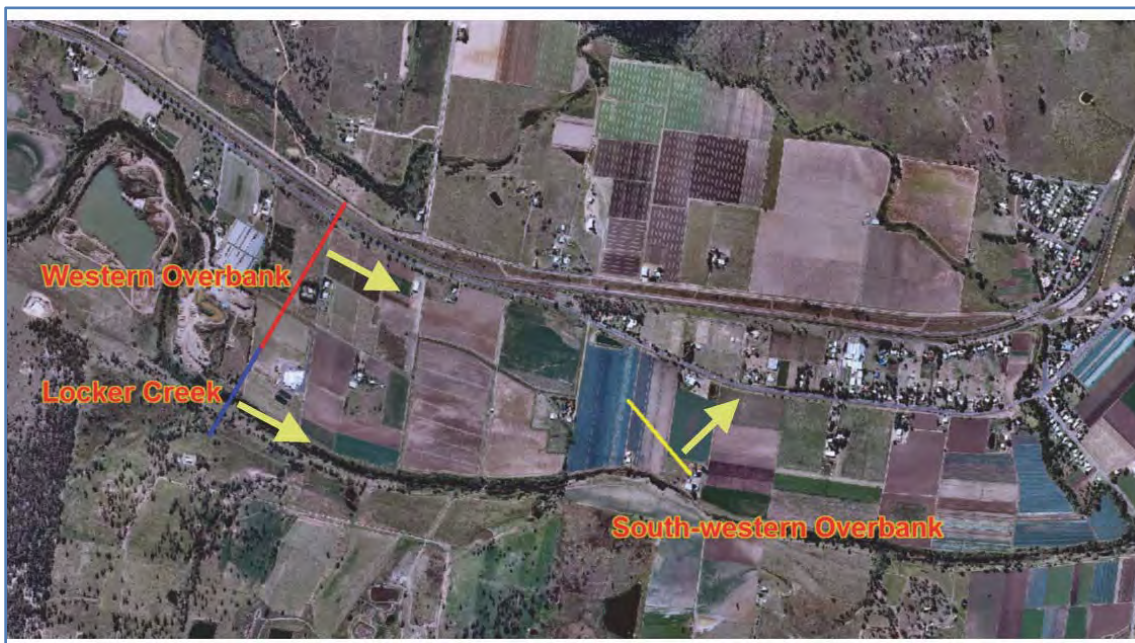

Figure C25: Downstream reporting locations

144, Dr John Macintosh, *Report to Grantham Floods Commission of Inquiry – Expert Hydrology Report 10 January 2011 – Circumstances and Contributing Factors, Supplementary Material No. 2*, 3 September 2015 [p10: Figure 1.1]

118. The downstream reporting locations were chosen for the following reasons:¹⁷⁸
- flows past the Lockyer Creek location affected all flooding that emanated from the downstream Lockyer Creek, including the south-western overbank flow from Lockyer Creek and Sandy Creek back flows;
 - flows past the western overbank location lead directly to western Grantham from the west; and
 - flows past the south-western overbank location represent the initial breakout front that first reached western Grantham from the south west.
119. There were four core reference points for the depth and flow intensity locations: near 25 Quarry Access Road, 1414 Gatton-Helidon Road, 12 Anzac Avenue and 26 Anzac Avenue¹⁷⁹. Each of those locations is marked in yellow in Figure C26 below.



Figure C26: Flow depth and intensity hydrograph locations.

Source: Exhibit 304, Dr John Macintosh, *Report to Grantham Floods Commission of Inquiry – Expert Hydrology Report 10 January 2011 – Circumstances and Contributing Factors Supplementary Material No. 2*, 3 September 2015 [p10: Figure 1.2] (amended)

120. Dr Macintosh chose the four core reference locations because they gave representative coverage of depth and flow intensity measurements within and around Grantham. Dr Macintosh also considered the depth and flow intensity measurements were good indicators for the quantification of flood hazard.¹⁸⁰
121. In addition to the four core reference locations, Dr Macintosh used seven reference points near the Grantham quarry for assessing the scenarios:
- a) near the residence at 1703 Gatton-Helidon Road;
 - b) near the residence at 1665 Gatton-Helidon Road;
 - c) near the residence at 1649 Gatton-Helidon Road;
 - d) to the west of the sheds near residence at 25 Quarry Access Road;
 - e) near the residence at 1617 Gatton-Helidon Road;
 - f) near the residence at 27 Dorrs Road; and
 - g) to the east of the produce store, in the paddock.¹⁸¹
122. Each of the seven additional locations are marked in red in figure C26 above. Dr Macintosh used these additional reference points to assess the localised impacts of the Grantham quarry.¹⁸²
123. Based on an assessment of the scenarios, Dr Macintosh’s opinion was that:
- a) it is most likely that the primary effect of the quarry was to delay the time of inundation of the Grantham area by one to three minutes. Dr Macintosh considered that this delay is associated with the time taken to fill the quarry pit,¹⁸³

- b) the magnitude of the flow intensity (velocity multiplied by depth) throughout the flood affected areas was likely to be extremely high (typically above $2\text{m}^2/\text{s}$) regardless of the scenario considered;¹⁸⁴
 - c) the quarry had a minimal effect on the flooding in Grantham in terms of flow depth, intensity or the rate of increase of intensity. The time of first inundation, time to reach flooding of 0.5 metres, and time to reach flow intensity of $0.5\text{ m}^2/\text{s}$ was one minute later in the most likely modelled scenario compared to the no quarry modelled scenario.¹⁸⁵
124. In the worst case (greatest delay)¹⁸⁶ and the most likely (greatest delay)¹⁸⁷ scenarios, the presence of the quarry produced a rapid increase in flow depth and intensity near 25 Quarry Access Road, but this occurred after that area had already been inundated.¹⁸⁸ The effect was entirely dissipated as the water travelled towards Grantham, which meant the rapid increase had a minimal effect on flood depth and intensity in Grantham even in these two scenarios.¹⁸⁹
125. While the full western embankment and the bunds were in place, they operated to temporarily restrict the flow of water into the quarry area.¹⁹⁰ This temporary constriction produced an increase in flood levels immediately to the west of the western embankment by about 0.2 metres. The increase in flood levels diminished further to the west of the quarry so that by Kapernick's Bridge, no increase is observed.¹⁹¹
126. Dr Macintosh prepared many flood hydrographs for the modelled scenarios at the downstream reporting locations. He also prepared a number of graphs depicting the effect of different scenarios on the flow intensity and flow depth at different locations. Figures C27 and C28 below compare the most likely scenario with the no quarry scenario and the no plant operations scenario (which is the no Grantham sand plant scenario).¹⁹²

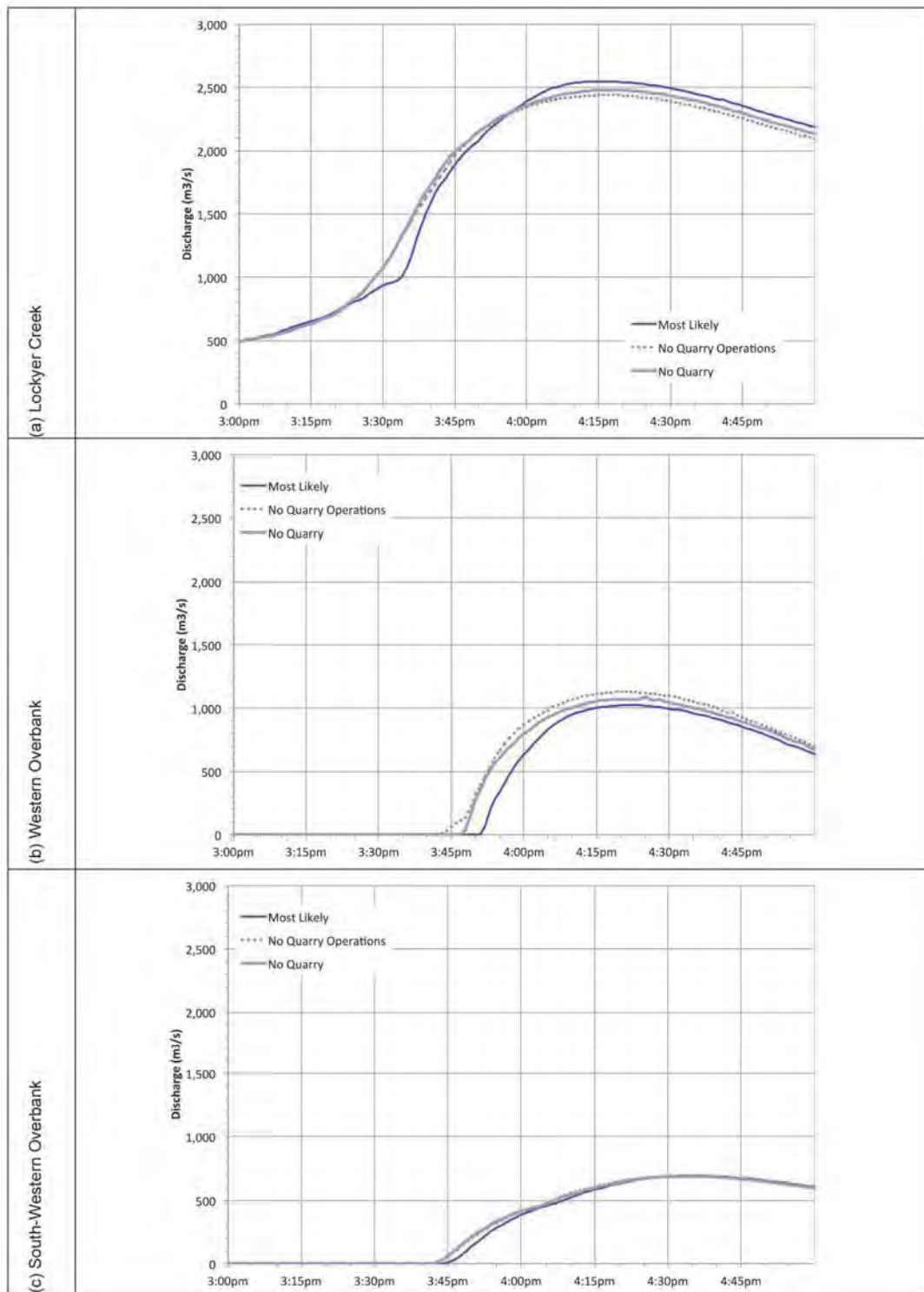

Figure C27: Effect of no quarry operations on downstream flow.
 Source: Exhibit 304, Dr John Macintosh, *Report to Grantham Floods Commission of Inquiry – Expert Hydrology Report 10 January 2011 – Circumstances and Contributing Factors Supplementary Material No. 2*, 3 September 2015 [p22: Figure 3.3].

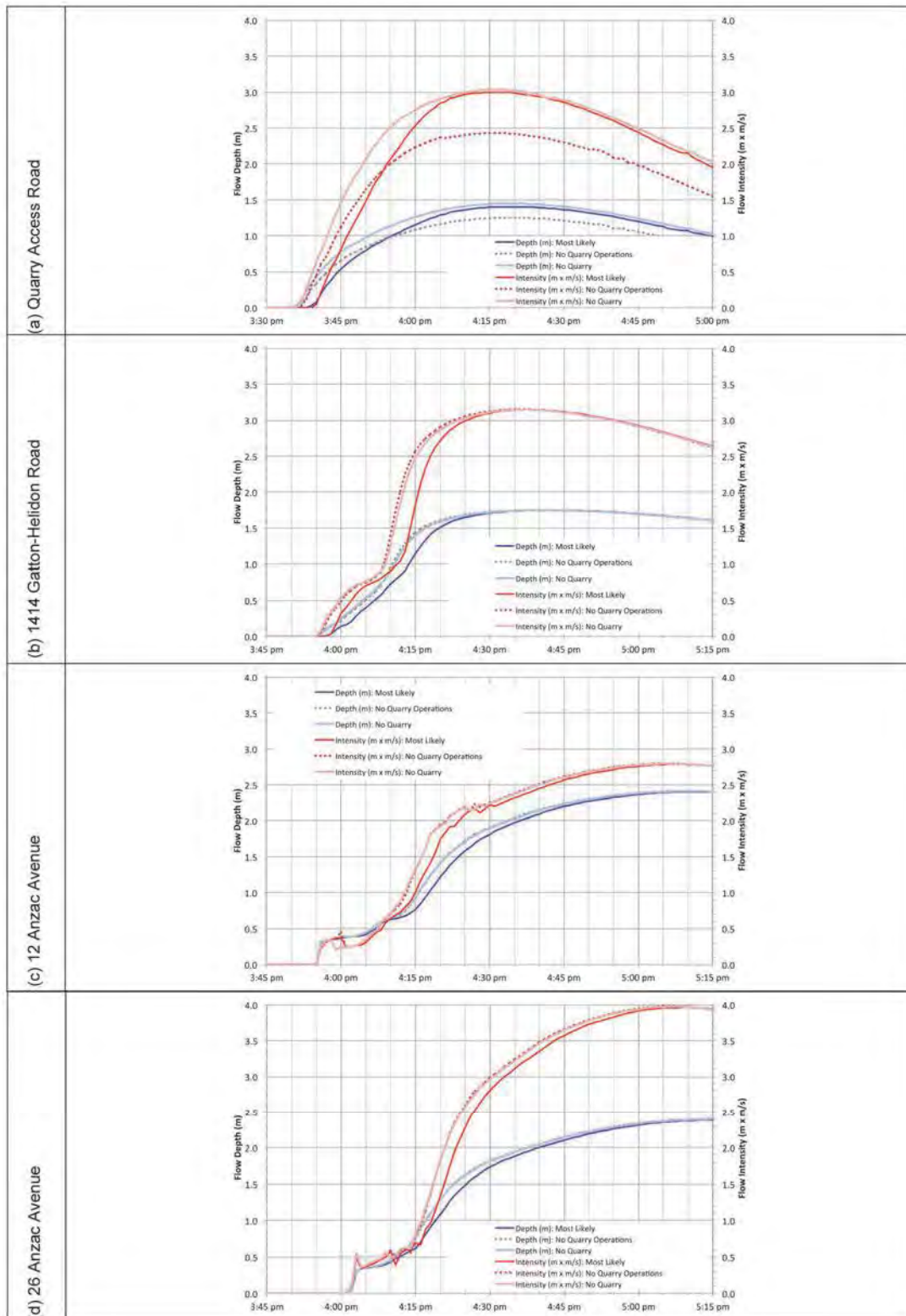

Figure C28: Effect of quarry operations on flow depth and intensity

Source: Exhibit 304, Dr John Macintosh, *Report to Grantham Floods Commission of Inquiry – Expert Hydrology Report 10 January 2011 – Circumstances and Contributing Factors Supplementary Material No. 2*, 3 September 2015 [p22-23: Figure 3.3 and Figure 3.4].

127. When the no Grantham sand plant scenario was compared to the no quarry scenario there was:
- no change to the delay times to the most likely scenario;
 - a slight reduction in the peak flow rate in the Lockyer Creek (approximately two per cent);
 - a small increase in the peak flow rate in the western overbank (approximately 10 per cent);
 - no apparent change in the peak flow rate in the south western overbank;
 - no apparent change in the peak flow depth and flow intensity at locations other than near 25 Quarry Access Road; and
 - a reduction in peak flow depth and flow intensity near 25 Quarry Access Road of about 0.2 metres (15 per cent) and 0.6 m²/s (20 per cent).¹⁹³
128. Dr Macintosh concluded the most likely effect of the existence of the Grantham sand plant (as opposed to the Grantham quarry) was to delay the time of inundation of the Grantham area by one to three minutes.¹⁹⁴
129. Dr Macintosh prepared several flood hydrographs for the seven additional flow intensity and flow depth locations surrounding the Grantham quarry. These included the hydrographs produced in Figures C29 to C35 below comparing the most likely scenario, no quarry scenario and no plant operations scenario (which is the no Grantham sand plant scenario).

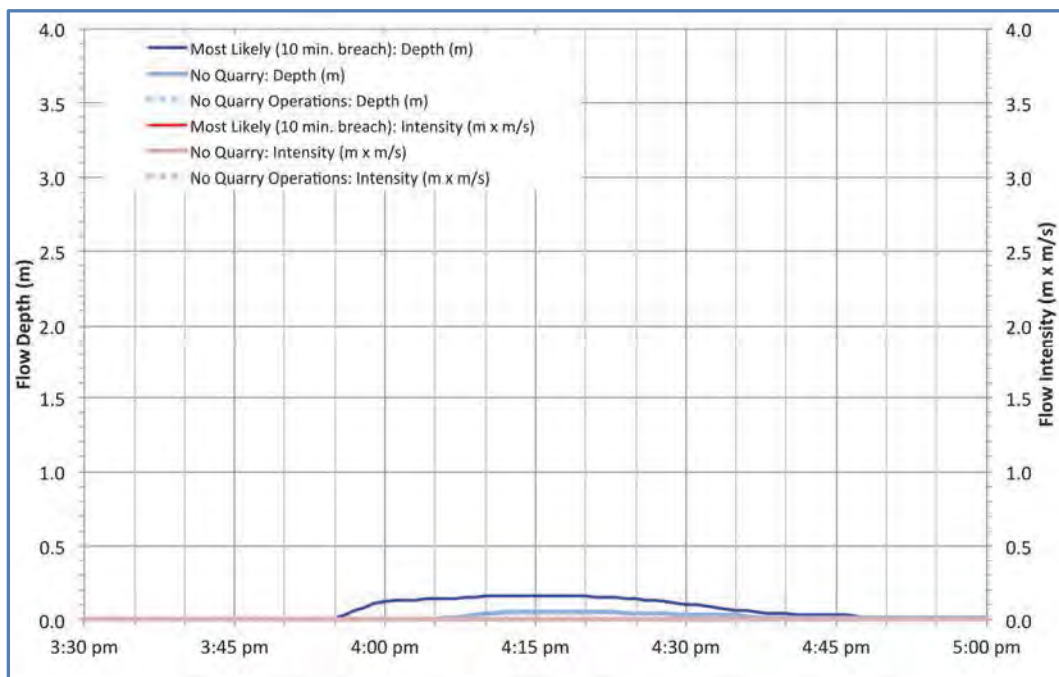

Figure C29: Comparison of flow depth and intensity at 1703 Gatton-Helidon Road

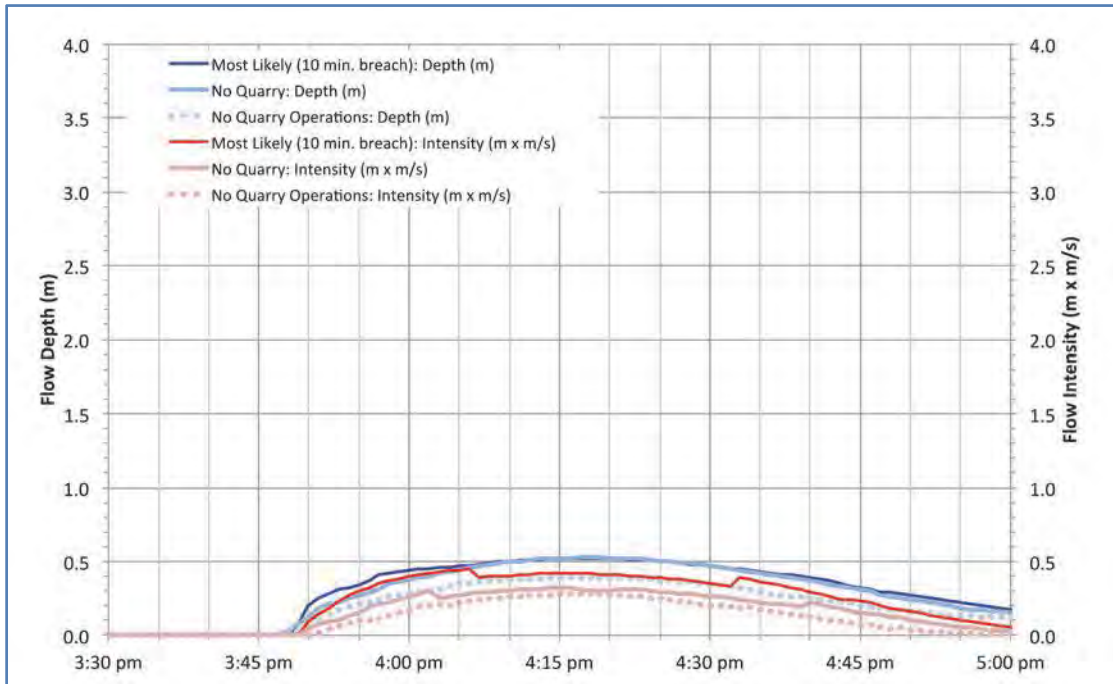

Figure C30: Comparison of flow depth and intensity at 1665 Gatton-Helidon Road

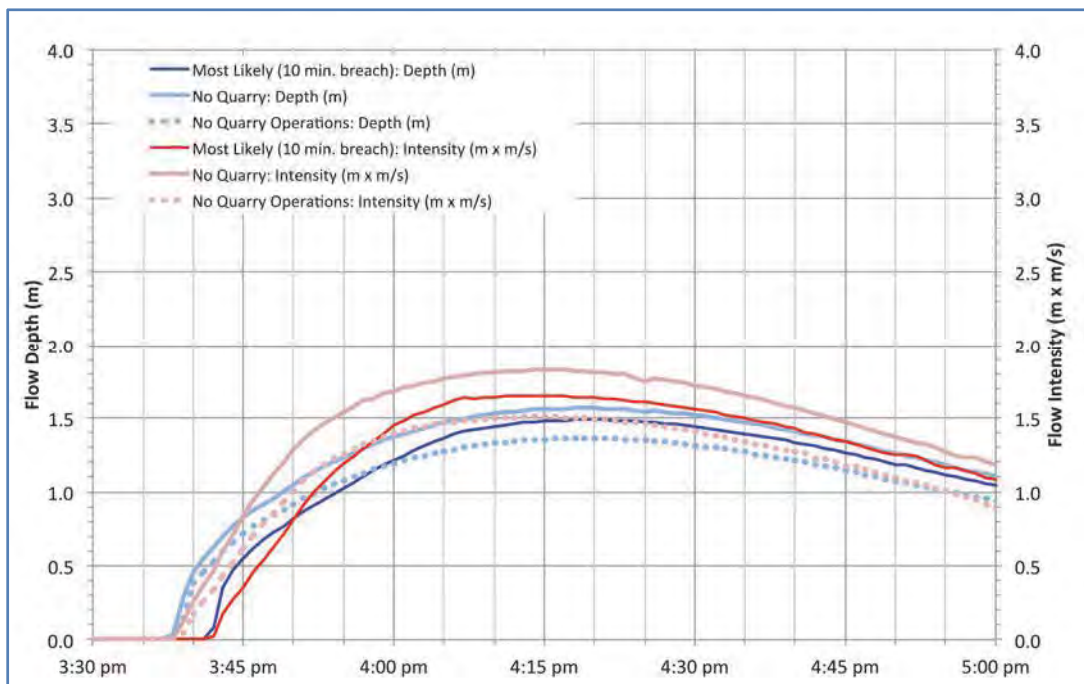

Figure C31: Comparison of flow depth and intensity at 1649 Gatton-Helidon Road

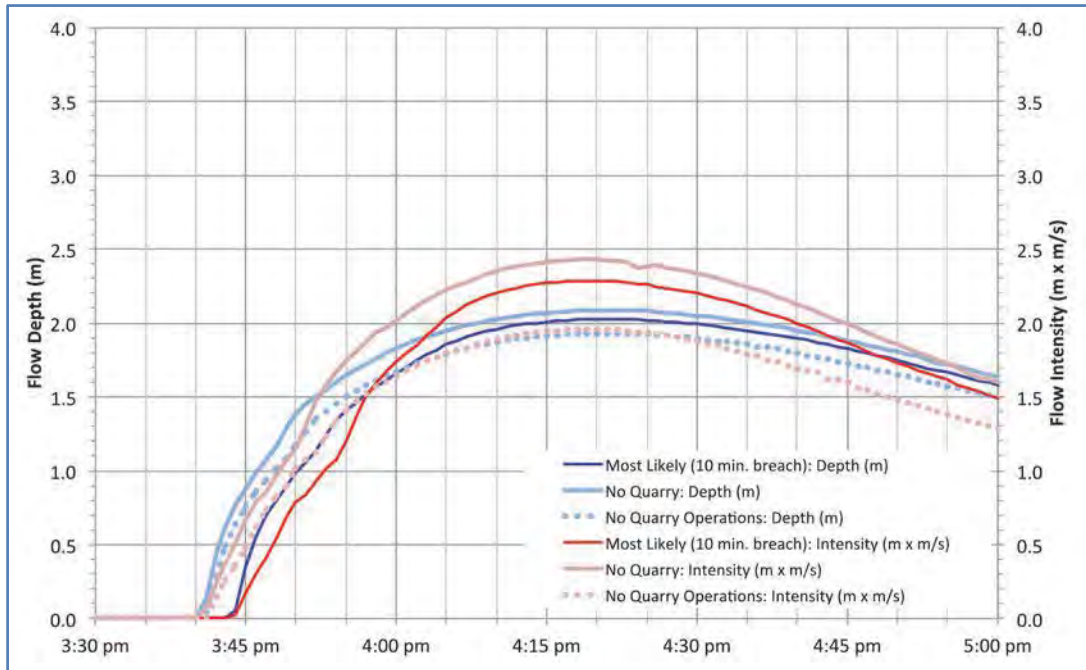

Figure C32: Comparison of flow depth and intensity at 25 Quarry Access Road

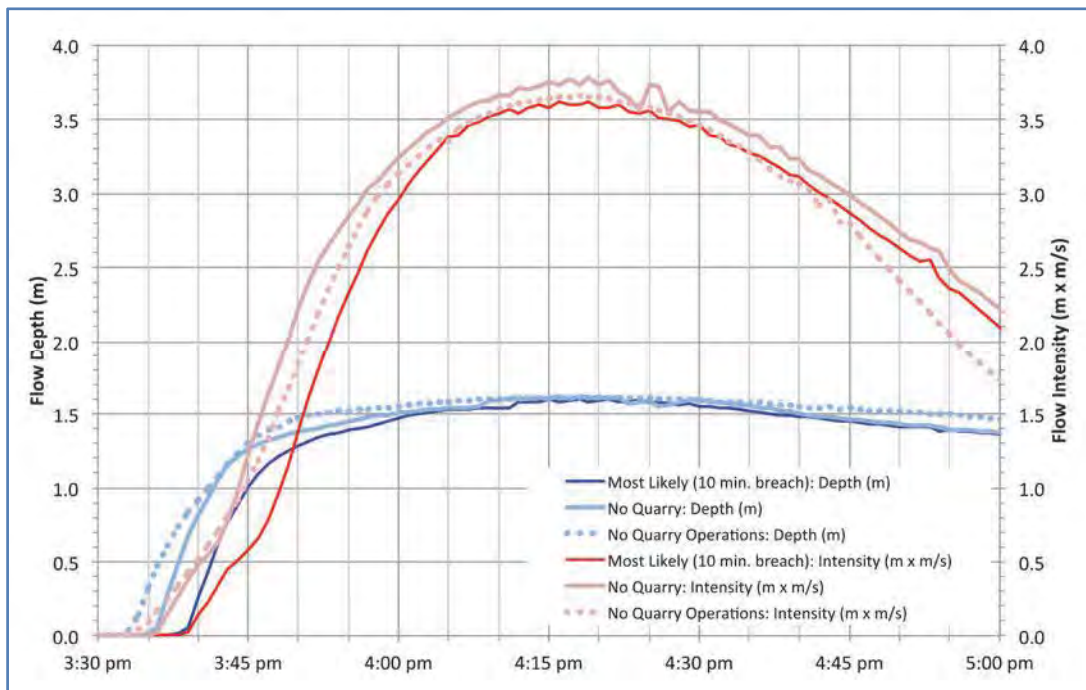

Figure C33: Comparison of flow depth and intensity at 1617 Gatton-Helidon Road

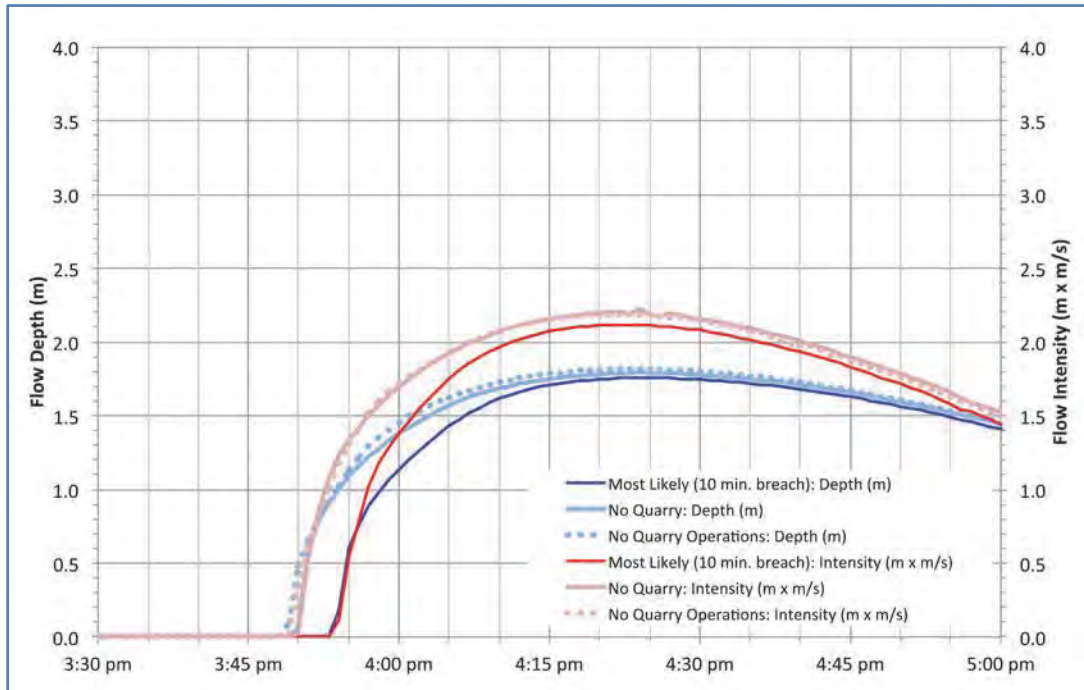

Figure C34: Comparison of flow depth and intensity at 27 Dorrs Road

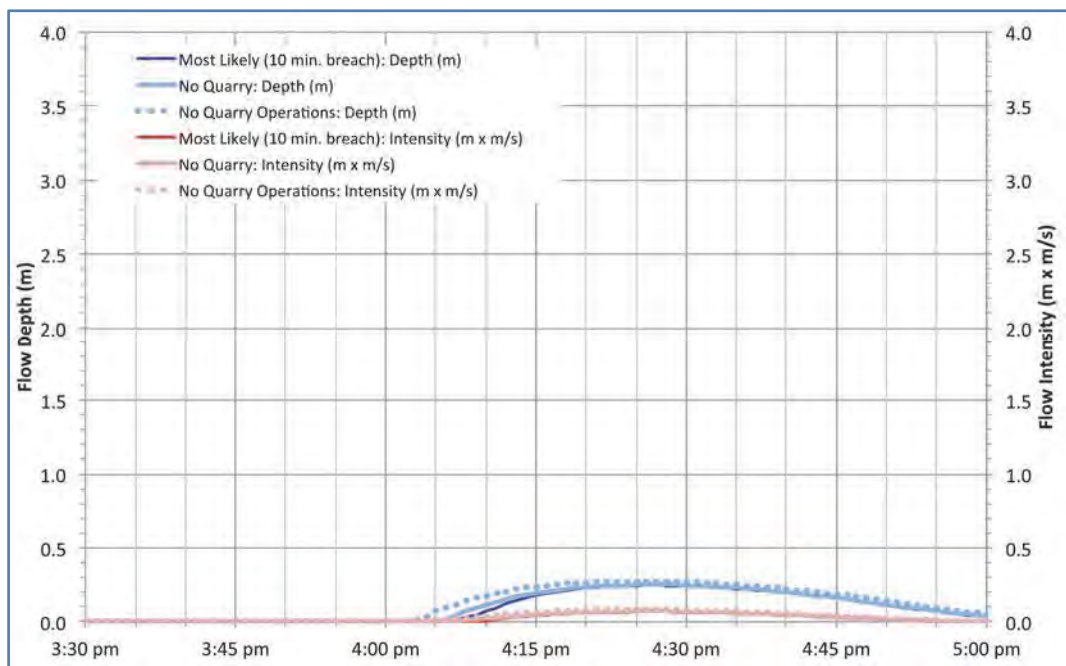

Figure C35: Comparison of flow depth and intensity at produce paddock

Source: Exhibit 304, Dr John Macintosh, *Report to Grantham Floods Commission of Inquiry – Expert Hydrology Report 10 January 2011 – Circumstances and Contributing Factors Supplementary Material No. 2*, 3 September 2015 [p25-28: Figures 3.5-3.11].

130. The Grantham quarry caused a minimal increase in flood depth at the 1703 Gatton-Helidon Road residence (an increase of 0.1 metres) and the 1665 Gatton-Helidon Road residence (an increase of 0.2 metres).¹⁹⁵ The effect dissipated as floodwaters travelled towards other properties surrounding the Grantham quarry (such as 1649 Gatton-Helidon Road) and Grantham itself.
131. Similarly, if the entire Grantham sand plant was brought back to natural ground level it produced a reduction in depth and flow intensity at 1665 Gatton-Helidon Road, 1649 Gatton-Helidon Road, 25 Quarry Access Road and 1617 Gatton-Helidon Road. However, those reductions were of the nature of 0.3 metres (in depth) and 0.5m²/s (in intensity) at their highest¹⁹⁶ and the reductions were not sufficient to reduce the overall flood hazard at those properties when compared to the most likely simulated depths and intensities at those locations.¹⁹⁷

Assessment of impact on evacuation

132. Dr Macintosh identified three evacuation routes from Grantham:

- Evacuation route 1 – Gatton-Helidon Road to the west;
- Evacuation route 2 – Gatton-Helidon Road to the east; and
- Evacuation route 3 – the railway underpass to the north of the railway embankment.¹⁹⁸

133. Each of these routes is identified in Figure C36 below.



Figure C36: Evacuation routes, Grantham

Source: Exhibit 144, Dr John Macintosh, *Report to Grantham Floods Commission of Inquiry – Expert Hydrology Report 10 January 2011 – Circumstances and Contributing Factors*, 11 August 2015 [p177: para 416].

134. Dr Macintosh adopted two indicator methods to determine the flood closure of these routes: when flow depth exceeded 0.3 metres or when flow intensity (depth multiplied by velocity) exceeded 0.5 m²/s.¹⁹⁹ The time of closure was the earliest at which one of these thresholds was reached.²⁰⁰
135. Dr Macintosh compared the most likely, no quarry and worst case (greatest drop) scenarios and identified when the thresholds were first reached at certain locations along the evacuation routes.²⁰¹ Those locations are marked A to E on figure C36 above. There are two locations at point D (railway underpass: Railway Street, and Ditchmans Road). In all scenarios for all locations, the depth criterion was always met before the intensity criterion.²⁰²

136. For the most likely scenario:
- Evacuation route 3 (the northern route) was the first to close. For eastern Grantham (Railway Street – point D), the time of closure simulated under the most likely scenario was 3:19 pm and for western Grantham (Ditchmans Road) it was 3:26 pm;
 - Evacuation route 1 (the western route) was the second to close. For 1615 Gatton-Helidon Road (point A), the time of closure simulated under the most likely scenario was 3:50 pm; and
 - Evacuation route 2 (the eastern route) was the last to close. This route was simulated to close under the most likely scenario following the closure of the Gatton-Helidon Road at the Sandy Creek Bridge (point C) at 3:56 pm followed by the closure of the Gatton-Helidon Road at point E at 4:45 pm.²⁰³
137. Dr Macintosh compared these simulated times of closure to the eyewitness account of Mr Troy Steffens who provided a series of time-stamped photographs which he took using a camera in his mobile phone along Gatton-Helidon Road on 10 January 2011.²⁰⁴ The results of that comparison demonstrated that Dr Macintosh's modelled times of closure were consistent with Mr Steffens' observations about the depth and timing of floodwaters at:
- Gatton-Helidon Road near Armstrong Road, approaching Anzac Avenue at 3:53 pm;
 - Gatton-Helidon Road bridge crossing at Sandy Creek at 3:56 pm; and
 - Gatton-Helidon Road past Citrus and approaching Sorrensen Street at 3:58 pm.²⁰⁵
138. Dr Macintosh compared the confirmed results for the most likely scenario to the simulated times of closure for the no quarry and worst case (greatest drop) scenarios. Those comparisons revealed that:
- the most likely scenario resulted in a slightly later closure time of all evacuation routes of up to four minutes compared to the no quarry scenario; and
 - the worst case (greatest drop) scenario resulted in a slightly later time of closure of around two to three minutes in eastern Grantham and adjacent to the Grantham quarry, ranging up to a small delay of up to two minutes in western Grantham compared to the no quarry scenario.²⁰⁶
139. Based on the above, Dr Macintosh concluded the effect of the Grantham quarry on evacuation was to delay the time of closure by evacuation routes by up to two minutes.²⁰⁷

Dr Macintosh's assessment of the impact of the railway embankment

140. Grantham is divided by a railway that runs east to west through the town and which is elevated above natural ground level by an embankment that extends up to approximately two metres in height.²⁰⁸

No railway embankment scenarios

141. To consider the effect of the railway embankment, Dr Macintosh developed two model scenarios:
- an initial no railway embankment scenario; and
 - an extended no railway embankment scenario.
142. The initial no railway embankment scenario modelled the effect of the flooding in Grantham if there had been no railway embankment to the north of western and central Grantham. Elsewhere, the embankment remained unchanged.²⁰⁹ The physical extent of the railway embankment considered modelled for that scenario is demonstrated in Figure C37 below.

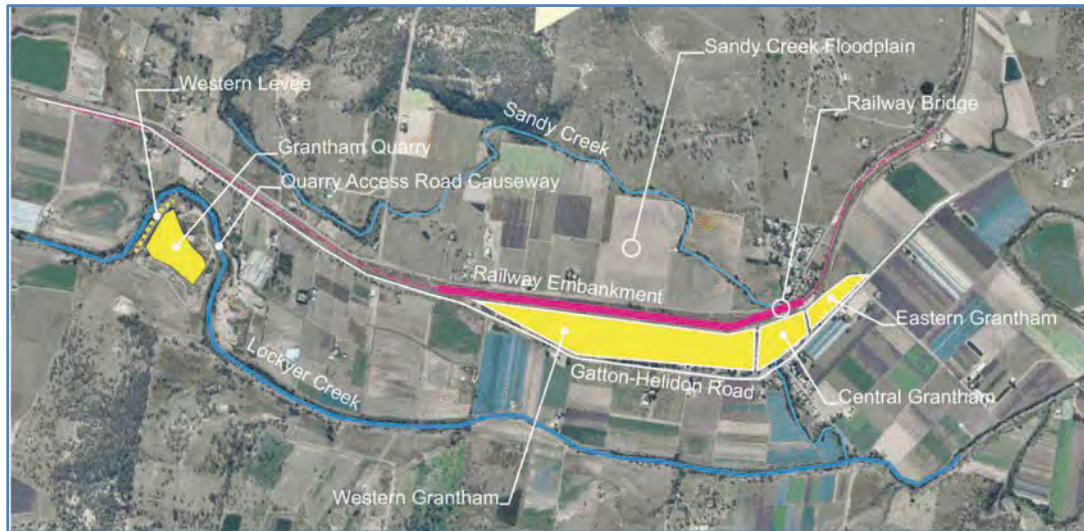

Figure C37: Grantham railway embankment locality

Source: Exhibit 144, Dr John Macintosh, *Report to Grantham Floods Commission of Inquiry – Expert Hydrology Report 10 January 2011 – Circumstances and Contributing Factors*, 11 August 2015 [p121: Figure 11.1].

143. The extended no railway embankment scenario was a revised version of the initial scenario. This scenario modelled the effect of the flooding in Grantham if the entire railway embankment throughout the GFCOI model was removed.²¹⁰ The physical extent of the railway embankment considered under that scenario is demonstrated in Figure C38 below.²¹¹



Figure C38: Extended railway embankment locality

Source: Exhibit 304, Dr John Macintosh, *Report to Grantham Floods Commission of Inquiry – Expert Hydrology Report 10 January 2011 – Circumstances and Contributing Factors Supplementary Material No. 2*, 3 September 2015 [p29: Figure 4.1].

144. For both railway embankment scenarios, Dr Macintosh used the most likely scenario as a base. Dr Macintosh then altered that scenario by removing the topography for the railway embankment and replacing it with the natural ground levels across the width of the railway corridor. To do this, Dr Macintosh relied on the topographic data supplied in the Lockyer Valley Regional Council model of that area.²¹²

145. Dr Macintosh also prepared animations depicting the progression of the flooding between 12 pm and 8 pm using both the no railway embankment scenario and the extended no railway embankment scenarios.²¹³

Assessment of railway embankment scenarios

146. Dr Macintosh compared these no railway embankment scenarios with the most likely scenario to determine the effect of the railway on maximum flow intensity, maximum flood depth and maximum flood velocity.²¹⁴

147. Dr Macintosh prepared a table analysing the average maximum flow intensity, depth and velocity observed across each of the scenarios. A copy of that table is below.

Item	With Railway	No Railway Embankment		No Extended Railway Embankment	
	Maximum	Maximum	Change	Maximum	Change
Average Intensity (m x m/s)	2.8	2.3	-0.5	2.2	-0.6
Average Depth (m)	2.6	2.4	-0.2	2.3	-0.3
Average Velocity (m/s)	1.2	1.1	-0.1	1.1	-0.1

Table C1: Flow parameters and change due to railway embankment

Source: Exhibit 304, Dr John Macintosh, *Report to Grantham Floods Commission of Inquiry – Expert Hydrology Report 10 January 2011 – Circumstances and Contributing Factors Supplementary Material No. 2, 3 September 2015* [p36: Table 4.1].

148. Dr Macintosh concluded that:

- a) the effect of the railway embankment was to intercept the flow of floodwaters that would otherwise have moved unrestricted into the Sandy Creek floodplain area to the north of the embankment;
- b) the result of that interception was to:²¹⁵
 - (i) direct the incoming flood flows from both the south-western overbank flow path and the western overbank flow path to an easterly direction, but at a greater depth and flow intensity than would otherwise have been the case had the embankment not been there; and
 - (ii) create a concentration of flood flow to the northern side of the embankment at the location of the Sandy Creek rail bridge crossing;
- c) the railway embankment increased maximum flood depths, velocities and intensities. In this respect, there was an increase in²¹⁶:
 - (i) peak flood depths from 2.3 metres (for the initial no railway scenario) to 2.6 metres (for the most likely scenario);
 - (ii) peak velocity from 1.1 metre (for both railway scenarios) to 1.2 metres (for the most likely scenario); and

- (iii) maximum intensity from 2.4 metres (for the extended no railway scenario) to 2.8 metres (for the most likely scenario); and
 - d) for all three scenarios, the flood hazard (as depicted by the average intensity) remained relatively high.²¹⁷
149. Dr Macintosh also considered the effect of the railway embankment on the flood depths and intensities at a house at 1420 Gatton-Helidon Road. To do this, Dr Macintosh produced flood hydrographs at three locations:
- a) in the centre of 1420 Gatton-Helidon Road (depth only);
 - b) outside and a short distance immediately to the north of the house; and
 - c) outside and a short distance immediately to the south of the house.²¹⁸
150. A copy of the figure containing those hydrographs is at Figure C39 below.
151. While there was a slight lowering in depth and intensity at this location in the no railway scenarios, the flood intensity and flood depth remained at extreme levels of well over 1.5 metres in depth and 2m²/s in intensity.²¹⁹ In Dr Macintosh's view, this meant that the flood hazard for Mr Bruce Marshall, who was located within the house, remained extreme across all three scenarios.

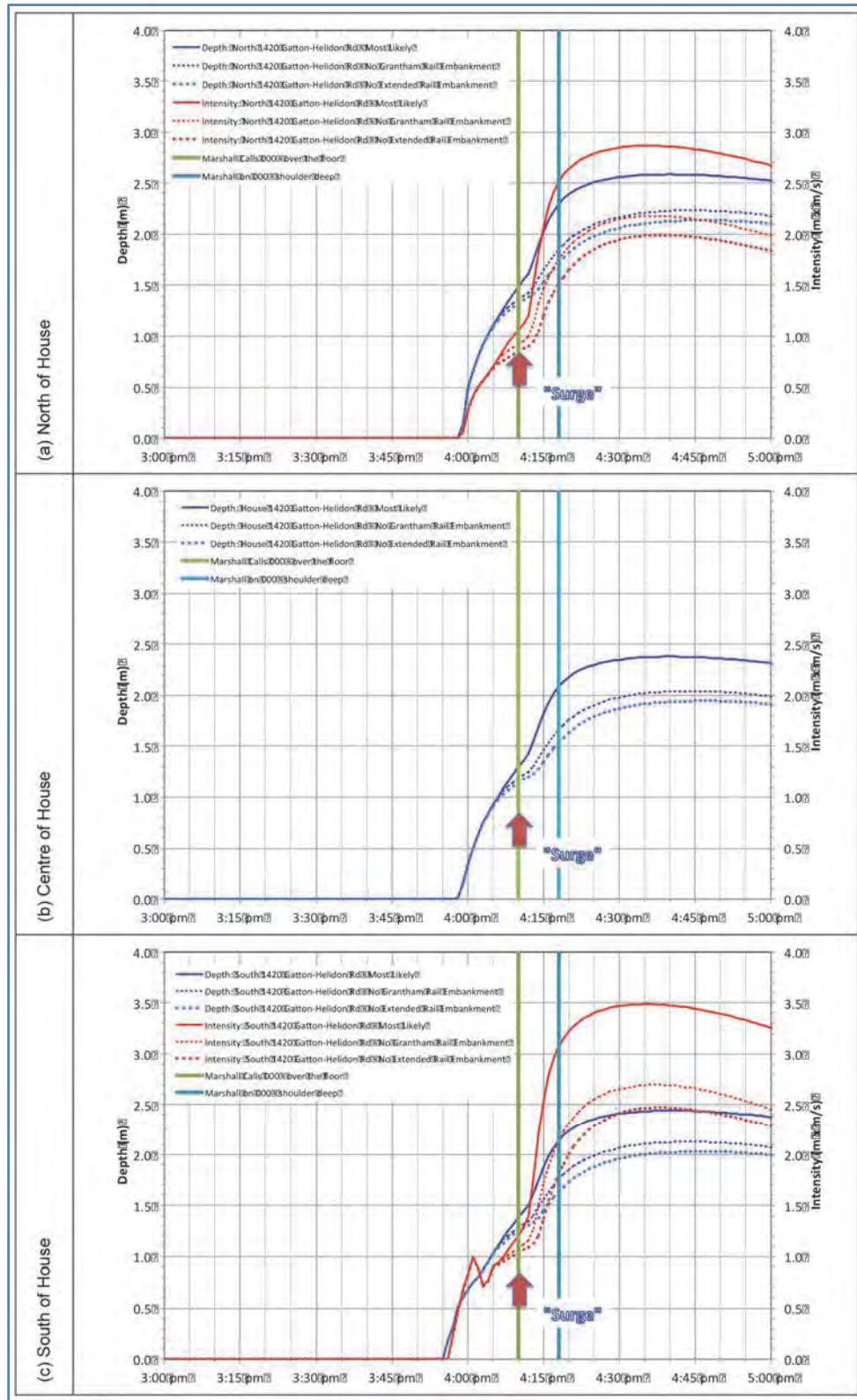

Figure C39: Flow depth intensity at the location of 1420 Gatton-Helidon Road
 Source: Exhibit 304, Dr John Macintosh, *Report to Grantham Floods Commission of Inquiry – Expert Hydrology Report 10 January 2011 – Circumstances and Contributing Factors Supplementary Material No. 2, 3 September 2015* [p35: Figure 4.11].

Overall conclusions reached by Dr Macintosh

152. Through the above analysis, Dr Macintosh examined the potential contribution of three factors on the flooding in Grantham:
- a) the Grantham quarry;
 - b) the Grantham sand plant; and
 - c) the railway embankment.
153. In Dr Macintosh's opinion, the most likely effect of the Grantham quarry and the Grantham sand plant was to delay the initiation of flooding in Grantham by between one to three minutes, and the time of closure of evacuation routes in Grantham by up to two minutes. The most likely effect of the railway embankment was to increase slightly maximum flood depths, intensities and velocities but not to increase those factors so substantially as to affect overall flood hazard, which would still have been extreme.
154. Further, in Dr Macintosh's opinion, none of these factors had any impact on the manner in which the flooding occurred. Across all modelled scenarios (and consistent with eyewitness accounts), the flooding occurred in three stages:
- a) inundation of the lower parts of central Grantham on from Sandy Creek, in a manner common to people's experience of flooding historically in Grantham;
 - b) a surge of water that came from the south west, from the Lockyer Creek; an unusual occurrence; and
 - c) a surge of water that came from the west that had broken out near 25 Quarry Access Road and travelled towards Grantham to join the south western flows.²²⁰
155. For the last two stages, the major contributing factor was the unprecedented volume of water coming down the Lockyer Creek.²²¹ In Dr Macintosh's view, this volume amounted to approximately 32 gigalitres by 8 pm. Of that figure, Dr Macintosh considered approximately 6 gigalitres or about 20 per cent of the flood volume flowed through western Grantham to 8 pm.²²²
156. Dr Macintosh's overall conclusion was that whatever changes were made to the quarry land or the railway embankment, if a similar volume of water fell into an already saturated catchment of the Lockyer Creek, there would be flooding with the same characteristics as that which occurred on 10 January 2011.²²³ Dr Macintosh also considered that none of the factors identified caused, altered or materially contributed to the flooding in Grantham on 10 January 2011.

Evidence of Mr Stefan Szykarski

157. Mr Stefan Szykarski is a Registered Professional Engineer with over 23 years' experience in water and environmental engineering and is employed by DHI Water & Environment Pty Ltd (**DHI**). Mr Szykarski specialises in, amongst other things, the application of flood models to water planning issues.²²⁴

Szylkarski report to the Commission

158. The Commission engaged Mr Szylkarski to review Dr Macintosh's reports and assess the adequacy of Dr Macintosh's work; and to provide an opinion and interpretation of the results presented in Dr Macintosh's reports.²²⁵
159. Mr Szylkarski provided his review and opinion in the form of an expert report to the Commission entitled *Review of Expert Hydrology Report – 10th January 2011 Grantham Flood* on 13 August 2015 (**Szylkarski August 2015 report**).²²⁶
160. Mr Szylkarski also gave evidence to the Commission during a public hearing on 20 August 2015.

Issues considered by Mr Szylkarski

First issue – model selection

161. In reviewing Dr Macintosh's work, Mr Szylkarski identified that Dr Macintosh had used the same model and model resolution as that applied by Dr Jordan.²²⁷ Mr Szylkarski had previously expressed reservations over the use of this model and the model resolution.
162. Mr Szylkarski now accepted that the 10 metre grid resolution adopted by Dr Macintosh and Dr Jordan was suitable²²⁸ having regard to the sensitivity analysis performed by Dr Macintosh in relation to the grid resolution for the model.²²⁹ Mr Szylkarski noted Dr Macintosh had tested the effect of a higher resolution grid (five metres) on the Commission model and had concluded the higher resolution only had an effect on the quarry pit.²³⁰
163. Mr Szylkarski also accepted that the use of the TUFLOW model was acceptable. Mr Szylkarski had been concerned by eyewitness accounts that had observed waves travelling across a floodplain during the onset of flooding that may have appeared as "breaking waves", similar to the movement of a breaking wave on a beach shoreline. The TUFLOW model was unable to simulate steep fronted waves²³¹. However, Mr Szylkarski considered that Dr Macintosh's model produced outcomes that closely aligned with the eyewitness accounts and observations about the timing of the flooding.²³² Indeed, Mr Szylkarski was surprised at how good the timing was as it was able to distinguish differences to the order of minutes. In Mr Szylkarski's view, this indicated that the calibration of the model was extremely accurate.²³³ If there had been a substantial impact from waves then there would not have been a correlation between Dr Macintosh's modelling and the timing of flooding events.²³⁴
164. Given this, Mr Szylkarski was not concerned about the inability of the model to capture steep fronted waves.²³⁵

Second issue – modelling of the western embankment and failure of the embankment

165. Mr Szylkarski was concerned to ensure that Dr Macintosh's work modelled:
 - a) the full extent of the breaches to the western embankment; and
 - b) a range of different starting times and durations of failure of the western embankment.²³⁶
166. Mr Szylkarski was satisfied that Dr Macintosh had modelled the full extent of the breaches to the western embankment.²³⁷
167. Mr Szylkarski was also satisfied that Dr Macintosh's model had assessed a range of different start times and durations of failure for the breach to the western embankment.²³⁸ In this respect, Mr Szylkarski considered the range of modelled scenarios prepared by Dr Macintosh and identified that those scenarios adequately addressed the envelope of starting times and durations of failure for the western embankment.²³⁹

Third issue – boundary conditions for the model

168. In reviewing Dr Macintosh's model, Mr Szykarski identified that Dr Macintosh had revised both the upstream and downstream boundary conditions for his model.²⁴⁰ In Mr Szykarski's view, it was important that each of these boundaries was accurate.
169. Mr Szykarski's view was that it was important that the downstream boundary condition was not set too close to the area of interest.²⁴¹ In other words, if the boundary condition was set too short, the model would fail to take into account the effects of topography and other conditions beyond the limits of the model and how they might have an effect on depths and other factors, for example, by causing water to back up and dampen the response of water levels.²⁴²
170. Mr Szykarski considered that Dr Macintosh's downstream boundary condition was accurate and reliable as it was based upon a rating curve derived from the floodplain characteristics. The use of a rating curve to set a downstream boundary condition was reliable because it allowed the downstream water level to move as the flow rate went up and down.²⁴³
171. It was important that the upstream boundary condition was accurate as it determined the amount of water flowing into the model. If that boundary was inaccurate then the model would not match the peak water levels observed during a flood.²⁴⁴ The most significant feature of the upstream boundary condition is the flow from Lockyer Creek.
172. Mr Szykarski considered that Dr Macintosh's upstream boundary condition produced using Dr Macintosh's revised rating curve for the Lockyer Creek was accurate and reliable. This was demonstrated by the close corroboration of Dr Macintosh's model against the peak survey flood levels.²⁴⁵

Fourth issue – Calibration and corroboration of the model

173. The final issue considered by Mr Szykarski was the corroboration of the outcomes produced by Dr Macintosh's model by first, the surveyed peak flood levels and second, the timing of flooding observed in eyewitness accounts.
174. Mr Szykarski observed a close correlation between Dr Macintosh's modelled peak flood levels and the surveyed peak levels within the town of Grantham and the immediate vicinity of the quarry.²⁴⁶ Although a mismatch was identified between the modelled peak flood levels and the peak levels observed further upstream of the quarry, he considered that the mismatch did not invalidate Dr Macintosh's modelling because the observed peak levels were not based on reliable survey data and were outside of the area of interest.²⁴⁷
175. In relation to the timing of flood events, Mr Szykarski observed a close correlation between Dr Macintosh's modelling and eyewitness accounts.²⁴⁸ Dr Macintosh's modelling also correlated with phone records and other time stamped documents relating to the 10 January flood, such as photographs and videos.²⁴⁹
176. Given the close correlation between Dr Macintosh's modelling as against peak flood levels and eyewitness accounts, Mr Szykarski considered that Dr Macintosh's model was appropriately calibrated and corroborated.²⁵⁰

Mr Szykarski's opinion as to the flooding in Grantham

177. After reviewing Dr Macintosh's modelling, Mr Szykarski reached the following principal conclusions:
- a) The most likely impact of the Grantham quarry was to:
 - (i) delay the onset of the flood flows in Grantham by approximately three minutes;²⁵¹ and

- (ii) slightly increase the rate of rise of flood flows to the peak of the flood by about three minutes faster.²⁵² The net result however was that the peak of the flood flows occurred at about the same time;²⁵³
 - b) The Grantham quarry did not affect the extreme flood hazard condition associated with the flooding in Grantham.²⁵⁴ Across all modelled scenarios, the flood intensity exceeded over 2m²/s; an indicator of extreme flood hazard;
 - c) The Grantham quarry did not affect the flooding behaviour observed during the 10 January 2011 flood.²⁵⁵ Across all modelled scenarios, the flooding occurred in three stages – flooding from Sandy Creek followed by two breakout flows from Lockyer Creek, one from the south-west and the other from near 25 Quarry Access Road. In Mr Szykarski’s view, this indicated that the flooding occurred in this manner due to the unique and natural configurations of the flow paths travelled by the two breakout flows from Lockyer Creek; and
 - d) The bunds on the western embankment caused an increase in flood levels immediately upstream of the quarry.²⁵⁶ While this increase resulted in a slightly increased contribution to flood flows after the breach of the bunds, that contribution was attenuated as the flood flows travelled across the flood plain and through the Lockyer Creek.²⁵⁷
178. These conclusions are, of course, consistent with those reached by Dr Jordan.
179. Mr Szykarski also considered that the worst case scenarios modelled by Dr Macintosh were unrealistic as they assumed a much greater height for the western embankment than identified by Mr Starr.²⁵⁸

Evidence of Dr David Newton

180. Dr Newton is a Chartered Professional Engineer with more than 24 years’ experience as a hydraulic engineer, providing specialist advice in surface water engineering, including hydraulic and hydrological modelling. Dr Newton is also the Director and Principal Engineer of WRM Water & Environment Pty Ltd.²⁵⁹

Scope of work performed by Dr Newton

181. Wagners engaged Dr Newton to investigate the impact of the Grantham Sand quarry on the January 2011 flooding in Grantham.²⁶⁰ The scope of the work included:²⁶¹
- a) a visit to the quarry site;
 - b) characterisation of Grantham flood behaviour through review of anecdotal flood information such as witness statements; and
 - c) computer flood modelling of alternative scenarios to determine how the flood behaviour in Grantham may have differed if the quarry embankment had not failed, had failed in different ways, or if the quarry pit had not existed at all.
182. Dr David Newton prepared two reports:
- a) Impact of the Grantham Sand quarry on the January 2011 Flood in Grantham, 3 July 2015 (**Newton Main Report**);²⁶² and
 - b) January 2011 flood in Grantham Supplementary Report 1, 17 August 2015 (**Newton Supplementary Report**).²⁶³
183. In conjunction with the Newton Supplementary Report, Dr Newton also provided four animations:²⁶⁴
- a) a validation animation that compared the eyewitness accounts to the results of the hydraulic modelling;

- b) a velocity animation that contained an assessment of flood velocity based upon the observed movement of debris;
 - c) a pre quarry comparison animations that compared two of Dr Newton's modelled scenarios, pre quarry and late/fast breach scenario; and
 - d) a Dinner Corner (late/fast) animation that magnified the validation animation file at the location of Dinner Corner.
184. No party requested that Dr Newton be called to give evidence during the public hearings before the Commission. Consequently, the material provided by Dr Newton was not challenged by any party.

Key Information relied upon by Dr Newton

185. In forming his opinion, Dr Newton had regard to the following information:
- a) eyewitness accounts of the flooding between Helidon and Grantham;²⁶⁵
 - b) the Jordan Report;²⁶⁶
 - c) the Szylkarski February 2015 report;²⁶⁷
 - d) a submission by Ms Amanda Gearing to the Queensland Floods Commission of Inquiry entitled 'Submission to the Queensland Floods Commission of Inquiry, Issues re Grantham quarry and flooding upstream and downstream', 7 November 2011;
 - e) Inquest into the deaths caused by the South-East Queensland floods of January 2011, Office of State Coroner, 5 June 2012;²⁶⁸
 - f) photographs of the inundation of a green shed at 152 Lockyer Creek Road, Helidon, taken from approximately 3:16 pm to 3:38 pm on 10 January 2011;
 - g) video footage produced by the channel 9 current affairs program '60 minutes' entitled 'The Missing Hour', 24 May 2015;
 - h) aerial video footage taken by channel 9 and channel 10 on 10 January 2011 over the Grantham area;²⁶⁹
 - i) peak flood level data in the Grantham area (excluding around the Grantham quarry), provided by Lockyer Valley Regional Council (LVRC);²⁷⁰
 - j) peak flood level data in the Grantham area, provided by Mr Richard Cork, a registered surveyor;²⁷¹
 - k) topographic data taken from LiDAR surveys taken in August 2010 and a few weeks after the January 2011 flood, provided by the LVRC;
 - l) a ground survey of the quarry area undertaken by OWR Surveyors in 2008;²⁷²
 - m) DNRM stream gauging stations historical water height and flow records; and
 - n) the models and supporting flood study report prepared by SKM²⁷³ for the LVRC.
186. In addition, Dr Newton undertook a site inspection of the Grantham quarry site.²⁷⁴

Preparation of Dr Newton's Model

187. Using the information above, Dr Newton also made use of a computer model to assist him in assessing the flooding in Grantham, and in particular, in assessing the impact of the Grantham quarry on the flooding in Grantham. Like

Dr Macintosh, Dr Newton use two computer models - 2D hydraulic (TUFLOW) and hydrology modelling (RAFTS).²⁷⁵

Extent of Modelled Area

188. In Dr Newton's view, simulation of a large floodplain area, such as the Lockyer Creek floodplain from Helidon to Grantham, required a large amount of computational effort which would increase the time required to undertake his modelling.²⁷⁶

189. Consequently, to reduce that time, Dr Newton developed two separate models using different versions of the TUFLOW software:²⁷⁷

- a) a model of the floodplain from Helidon to Gatton using TUFLOW GPU (the **GPU Model**); and
- b) a model of a shorter reach from upstream of the Grantham quarry to downstream of Grantham using TUFLOW classic (the **CPU Model**).

190. The extent of the GPU and CPU models is shown in the below figure, as provided by Dr Newton.

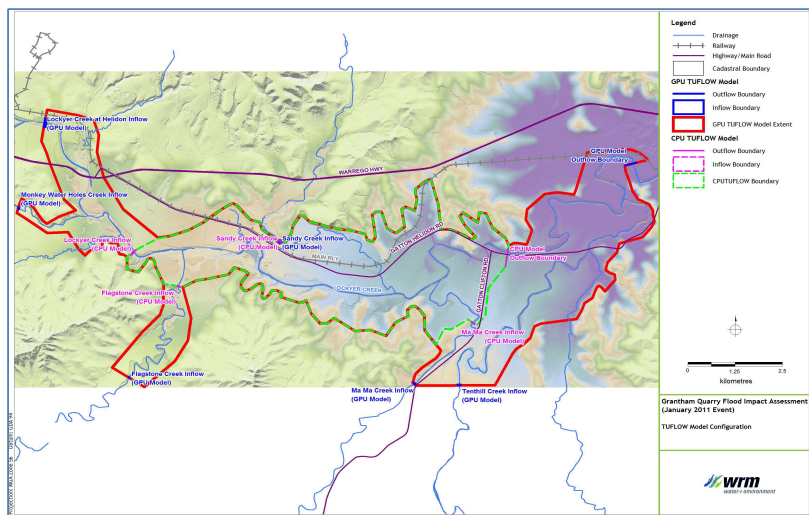

Figure C40: Boundaries of the GPU and CPU models.

Source: Exhibit 19, Dr David Newton, *Impact of the Grantham Sand quarry on the January 2011 Flood in Grantham*, 3 July 2015 [p50: Figure 6.1].

Key parameters for the Dr Newton Model

191. Dr Newton considered the following key parameters for his model:

- a) the inflow hydrographs for the Lockyer Creek and the other tributary creeks in the modelled area;
- b) the upstream and downstream boundaries to be applied to the modelled area;
- c) the topography for the modelled area including the Grantham quarry;
- d) the time of initiation and duration of breach to the western embankment to the Grantham quarry; and
- e) the hydraulic roughness parameters to be applied to the modelled area.

Inflow hydrographs for Lockyer Creek and the other tributary creeks

192. In Dr Newton's opinion, the flood flows across the modelled area were a combination of the upstream flows from the Lockyer Creek and inflows from the tributary creeks.²⁷⁸
193. To determine those flood flows, Dr Newton derived inflow hydrographs for the following:²⁷⁹
- Lockyer Creek at the Helidon stream gauge;
 - Flagstone Creek;
 - Ma Ma Creek;
 - Tenthill Creek;
 - Sandy Creek; and
 - Monkey Waterholes Creek.
194. In order to derive those hydrographs, Dr Newton used data provided by DNRM's stream gauges for all of the above locations save for Monkey Waterholes Creek.²⁸⁰ In the absence of a stream gauge for Monkey Waterholes Creek, Dr Newton used the inflow hydrograph for that location derived from rainfall as contained in the LVRC Models.²⁸¹
195. Dr Newton undertook a review of the stream gauge data for the Lockyer Creek at Helidon for 10 January 2011 available from DNRM. Based on that review, Dr Newton observed that:²⁸²
- the maximum flow prior to the 10 January 2011 floods for that gauge was 108m³/s on 12 April 1988 at a gauge level of 3.40 metres;
 - the gauge had failed during the 10 January 2011 floods, with the last recorded gauge height being 10.857 metres at 2:40 pm;
 - DNRM had estimated the peak water level for the gauge as 13.88 metres with a peak flow rate of 3,650m³/s. These values were far in excess than the previous maximum flow for that gauge; and
 - DNRM had prepared an inflow hydrograph for the Helidon gauge for 10 January 2011 using its estimated values of peak water level and peak flow rate.
196. Dr Newton then tested the DNRM inflow hydrograph by running it through his model. In Dr Newton's opinion, the results of that testing revealed that DNRM's inflow hydrograph had underestimated the peak flow for the gauge at Helidon. This was because the simulated flood levels using that hydrograph did not match with the peak flood levels observed during the 10 January 2011 flood.²⁸³
197. In Dr Newton's view, this discrepancy was associated with the degree of vegetation surrounding the Helidon gauge that was stripped during the flood, and the roughness of the surface over which the floodwaters travelled through Grantham.²⁸⁴
198. Dr Newton derived a new inflow hydrograph for the Lockyer Creek at the Helidon gauge using the same process as Dr Macintosh – namely, by firstly by creating a rating curve that took into account the discrepancies observed²⁸⁵ and then using that rating curve to derive an inflow hydrograph.²⁸⁶ The inflow hydrograph derived by Dr Newton is indicated in Figure C41 below.

199. Dr Newton undertook a review of the gauge data for the tributaries that was available from DNRM. Based on the results of that review, Dr Newton considered that the inflow hydrographs derived by DNRM for each of Flagstone Creek, Ma Ma Creek, Tenthill Creek and Sandy Creek were suitable for his model.²⁸⁷

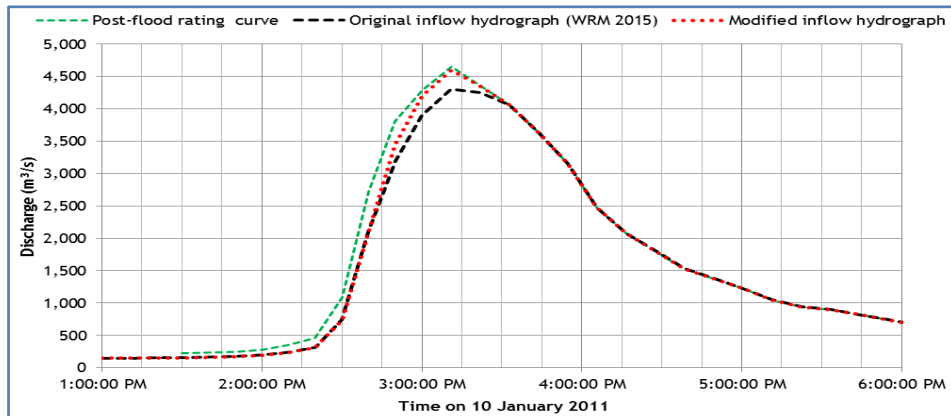

Figure C41: Inflow hydrograph.

Source: Exhibit 166, Dr David Newton, *January 2011 flood in Grantham Supplementary Report 1*, 17 August 2015 [p27: Figure 4.1].

200. As there was no gauge data available for Monkey Waterholes Creek, Dr Newton adopted the inflow hydrograph as derived in the LVRC models for this location in his model.²⁸⁸
201. The inflow hydrographs adopted for the tributaries are indicated in Figure C42 below. In reviewing this figure, it should be noted that the Lockyer Creek hydrograph is incorrect – the hydrograph adopted by Dr Newton for Lockyer Creek is that shown in Figure C41 above.

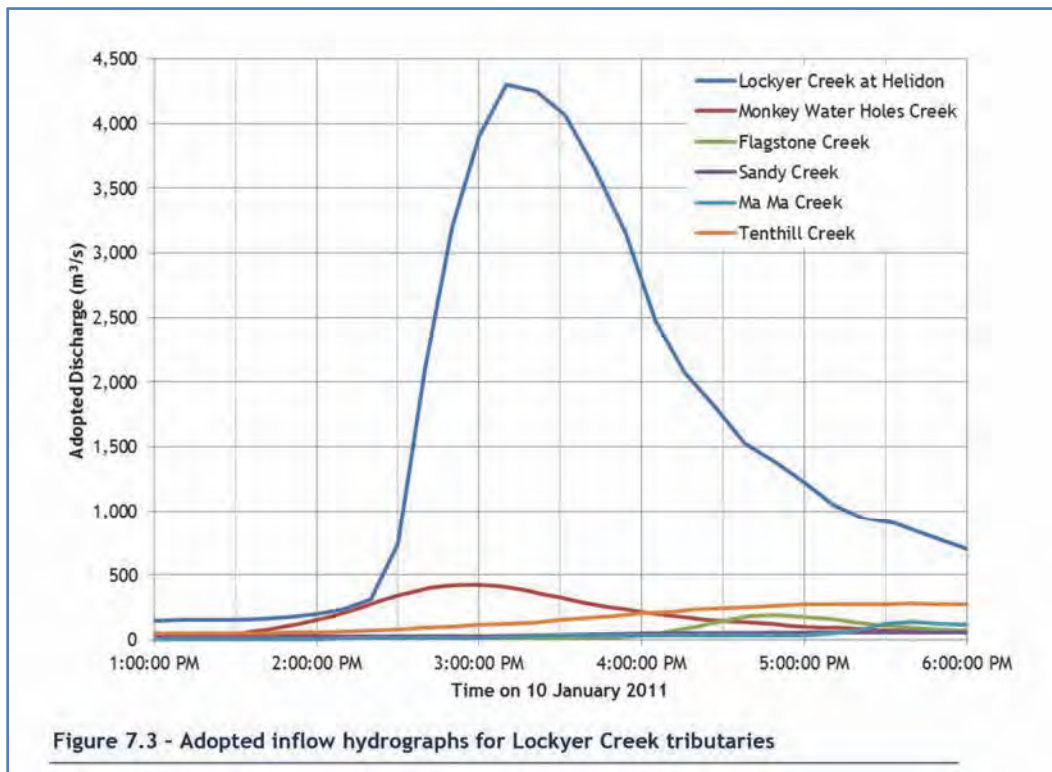

Figure C42: Inflow hydrographs for tributaries.

Source: Exhibit 19, Dr David Newton, *Impact of the Grantham Sand quarry on the January 2011 Flood in Grantham*, 3 July 2015 [p56: Figure 7.3].

Upstream and Downstream boundaries for the modelled area

202. Dr Newton set the upstream boundaries for the modelled area:²⁸⁹

- a) for the GPU Model, as the inflow hydrographs derived for each of:
 - (i) Lockyer Creek at the Helidon Gauge;
 - (ii) Flagstone Creek;
 - (iii) Ma Ma Creek;
 - (iv) Tenthill Creek;
 - (v) Sandy Creek; and
 - (vi) Monkey Waterholes Creek; and
- b) for the CPU Model, the inflow hydrographs for Lockyer Creek at the Helidon stream gauge, Flagstone Creek, Ma Ma Creek and Sandy Creek.

203. Dr Newton set the downstream boundaries:²⁹⁰

- a) for the GPU Model, as the recorded water level at Gatton; and
- b) for the CPU Model as a rating curve derived from the recording water level at Gatton.

Topography for the modelled area

204. Dr Newton considered the data obtained from the LiDAR surveys taken in August 2010 and within a few weeks after the January 2011 flood.

In particular, Dr Newton considered whether modifications were needed to that data to address local features in the topography between Helidon and Grantham, including the topography of the Grantham quarry and in particular, the breach to the bunds on the western embankment to the Grantham quarry.

205. Dr Newton identified that the data did not appropriately take into account the presence of the Carpendale Weir. Consequently, Dr Newton modified the data so as to lower the bed levels upstream of the weir between Flagstone Creek and the Grantham quarry. Dr Newton considered this was necessary so that those bed levels matched the bed levels of the Lockyer Creek that were unaffected by the weir pool.²⁹¹

206. Dr Newton identified that the data appropriately modelled:²⁹²

- a) the topography of the Grantham quarry pre-flood (based on the August 2010 data);
- b) the topography of the Grantham quarry post-flood (based on the January 2011 data); and
- c) the breaches to the western embankment of the Grantham quarry.

207. Dr Newton observed that the data modelled three separate breaches to the bunds on the western embankment. Dr Newton prepared a cross-section of the western embankment in which he identified those breaches as follows:²⁹³

- a) Section 1 – a breach between the Lockyer Creek and the quarry pit that was up to eight metres deep and about 50 metres wide;
- b) Section 2 – a breach associated with erosion of approximately 170 metres in width; and
- c) Section 3 – a breach associated with erosion of approximately 90 metres in width.

208. In total, Dr Newton observed breaches totalling approximately 310 metres in length along the western embankment. A copy of the cross-section (with the southern end indicated to the left and the northern end indicated to the right) is at Figure C43 below.

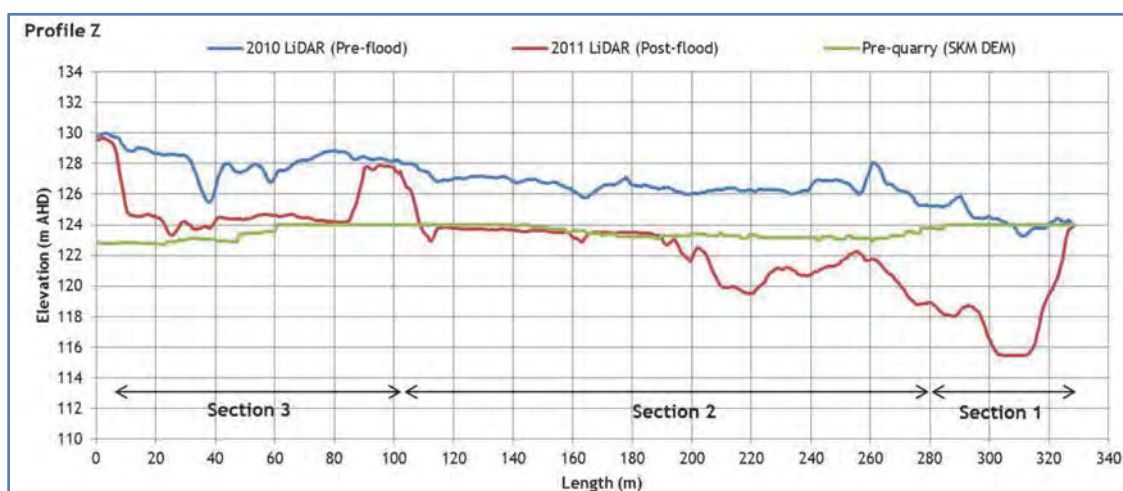

Figure C43: Cross section of western embankment.

Source: Exhibit 19, Dr David Newton, *Impact of the Grantham Sand quarry on the January 2011 Flood in Grantham*, 3 July 2015 [p23: Figure 3.4].

The time of initiation and duration of breach of the western embankment

209. Dr Newton considered he could identify no objective evidence from the January 2011 flood to quantify the initiation and duration of the breaches with any certainty.²⁹⁴
210. Consequently, Dr Newton developed three breach scenarios:²⁹⁵
- late/fast breach – a scenario which assumed all three sections of the western embankment failed at 3:50 pm and fully eroded to post-flood levels within one minute;
 - late/slow breach – a scenario which assumed all three sections of the western embankment started to fail at 3:50 pm, with Section 1 to erode over 20 minutes and Section 2 and 3 to erode over 15 minutes; and
 - early/slow breach – a scenario that assumed sections 1, 2 and 3 of the western embankment started to erode when the upstream water level reached 125 metres AHD (for Section 1), 126 metres AHD (for Section 2) and 127 metres AHD (for Section 3). Section 1 was to erode over 20 minutes with Section 2 and Section 3 to erode over 15 minutes.

Hydraulic roughness parameters

211. For his model, Dr Newton adopted the values for the hydraulic roughness parameter, Manning's *n*, developed for the LVRC models at most locations. He made some modifications to improve the calibration between his modelled outcomes and observations of the 10 January 2011 flood.²⁹⁶ The values adopted by Dr Newton are set out in Table C2 below.

Land use	Adopted Manning's <i>n</i> values	Modified Manning's <i>n</i> values
	Manning's <i>n</i>	Manning's <i>n</i> Revised calibration
Channel	0.04 (in weir pool) – 0.08	0.03 (in weir pool) – 0.08
Creek banks	0.05 – 0.08	0.05 – 0.09
Floodplain	0.05 (> 1 m depth) – 0.08 (< 0.3 m depth)	0.04 (> 1 m depth) – 0.07 (< 0.3 m depth)
Demolished building	0.03 (> 1.5 m depth) – 0.10 (< 1.0 m depth)	-
Building	4.00	-
Road	0.025	-
Dense vegetation	0.10	-
Low-medium vegetation	0.07	-

Table C2: Manning's *n* values adopted for the Newton model.

Source: Exhibit 19, Dr David Newton, *Impact of the Grantham Sand quarry on the January 2011 Flood in Grantham*, 3 July 2015, [p51, Table 6.1]; Exhibit 166, Dr David Newton, *January 2011 flood in Grantham Supplementary Report 1*, 17 August 2015, [p26: Table 4.1].

Validation of Dr Newton's Model

212. After developing the key parameters for his model, Dr Newton considered it necessary to validate his model against eyewitness accounts, peak flood levels, and flow velocities observed on 10 January 2011.

213. In order to undertake this process, it was necessary for Dr Newton to adopt one of the three breach scenarios he had developed for the western embankment for the Grantham quarry. Dr Newton adopted the late/fast breach scenario because it appeared to better match observed peak water levels and it was likely to produce a greater impact than the other breach scenarios.²⁹⁷

Validation against eyewitness accounts

214. Dr Newton considered the eyewitness accounts of a number of residents of Grantham, contained in witness statements as well as transcripts of the hearings before this Commission. In some instances, the eyewitness accounts included photographs and video footage of the flooding that occurred on 10 January 2011.

215. In Dr Newton's view, the available witness information varied widely in its level of precision, depending on the circumstances of the observer at the time and the accuracy with which they were able to recall events up to four years after they occurred.²⁹⁸ However, Dr Newton noted that some of the information provided had been quantified through the timing of telephone calls, time-stamped photographs and video.²⁹⁹

216. Given this, Dr Newton focused on time-stamped photographic and video evidence.³⁰⁰ Dr Newton did, however, give consideration to more general descriptions of flood behaviour such as the directions of water flow and the relatively sudden change in the character of flooding in areas affected by floodwaters from Sandy Creek.³⁰¹

217. Dr Newton's comparison focused on the flooding events as observed by the following eyewitnesses:³⁰²

- a) Mr Anthony McIntosh;
- b) Ms Annaka Sippel;
- c) Ms Helen Besley;
- d) Mr Jonathan Sippel;
- e) Mr Troy Steffens;
- f) Mr Matthew Stibbard;
- g) Mr Luke Owen;
- h) Mr Ian Pinkerton;
- i) Mr Wayne Lack;
- j) Mr Lance Richardson;
- k) Ms Katherine Godley;
- l) Mr Daniel McGuire; and
- m) Mr Martin Warburton.

218. The results of that comparison was as follows:

- a) in relation to Mr Anthony McIntosh, consistency between the model outcomes and the location and extent of floodwater shown in photographs taken at 3:08 pm and 3:20 pm;³⁰³
- b) in relation to Ms Annaka Sippel, consistency between the model outcomes and the timing and extent of floodwaters observed in a photograph taken at 3:45 pm at 1649 Gatton-Helidon Road;³⁰⁴

- c) in relation to Ms Helen Besley, consistency between the model outcomes and the rise and extent of floodwaters observed by Ms Besley during a 000 call placed at 3:47 pm near 25 Quarry Access Road;³⁰⁵
 - d) in relation to Mr Jonathan Sippel, consistency between the model outcomes and Mr Sippel's observations of the running of water down the northern side of the railway line from Dinner Corner towards Sandy Creek;³⁰⁶
 - e) in relation to Mr Troy Steffens, consistency between the model outcomes and the rise of floodwaters at Gatton-Helidon Road observed in a photograph taken at 3:58 pm while Mr Steffens was driving west along that road;³⁰⁷
 - f) in relation to Mr Matthew Stibbard, consistency between the model outcomes and the progressive inundation of the northern floodplain of Lockyer Creek downstream of the Grantham quarry, as observed in photographs taken at 3:57 pm and 4:07 pm at the Stanbroke beef works;³⁰⁸
 - g) in relation to Mr Luke Owen, consistency between the model outcomes and a photograph taken at 4:13 pm north of the railway line showing the inundation of the south side of the railway track as well as the ponding of floodwaters against the railway embankment;³⁰⁹
 - h) in relation to Mr Ian Pinkerton, consistency between the model outcomes and the progression of inundation of floodwaters at 1347 Gatton-Helidon Road, observed in three videos taken at that location after 3:30 pm;³¹⁰
 - i) in relation to Mr Wayne Lack, a slight inconsistency between the model outcomes and the rapid rate of rise of floodwaters observed in photographs taken by Mr Lack between 4:12 pm and 4:23 pm at 26 Anzac Avenue. The inconsistency observed was a difference of two minutes between the modelled rate of rise (occurring at 4:10 pm) and the observed rate of rise (occurring at 4:12 pm);³¹¹
 - j) in relation to Mr Lance Richardson, consistency between the model outcomes and the rise of floodwaters observed in videos taken by Mr Richardson at 12 Anzac Avenue between 4:14 pm and 4:36 pm;³¹²
 - k) in relation to Ms Katherine Godley, consistency between the model outcomes and the arrival of overbank flow from Lockyer Creek at 4:07 pm as observed in a video taken at 1338 Gatton-Helidon Road;³¹³
 - l) in relation to Mr Daniel McGuire, consistency between the model outcomes and extent of inundation of Gatton-Helidon Road described in 000 calls placed by Mr McGuire at 4:15 pm and 4:21 pm;³¹⁴ and
 - m) in relation to Mr Martin Warburton:
 - (i) consistency between the modelled outcomes and the water levels observed in photographs and videos taken by Mr Warburton between 4:09 pm and 4:34 pm;³¹⁵ and
 - (ii) an inconsistency between the modelled outcomes and Mr Warburton's observations of the flood rising in a sudden surge, dropping substantially and then rising again. The modelled outcomes did not show this phenomenon but did show a sudden surge of floodwaters that decreased gradually – it did not show a further rise of floodwaters after the decrease.³¹⁶
219. On the basis of these results, Dr Newton considered that his model matched, within a few minutes, the time-stamped photographs and videos taken by Grantham residents during the flood.³¹⁷ Dr Newton was, however, unable to explain the inconsistency between Mr Warburton's observations and his modelling save that he considered those observations were inconsistent with the photographs and videos taken by Mr Warburton during 10 January 2011.
220. Dr Newton also produced an animation of his modelling which included some of the eyewitness photographs and videos mentioned above. That animation accompanied his report.³¹⁸

Validation to peak flood levels

221. Dr Newton was provided with two sets of peak flood data:³¹⁹
- data provided by LVRC in the Grantham area (excluding around the Grantham quarry); and
 - data in the Grantham area, provided by Mr Richard Cork, a registered surveyor.
222. While Dr Newton initially chose to validate his model against the data provided by LVRC,³²⁰ he later preferred to validate the model solely against the data provided by Mr Cork.³²¹
223. The results of that comparison revealed a difference between modelled outcomes and Mr Cork's survey levels of between -0.31 metres and 0.22 metres, with an average difference of -0.06 metres. That is, Dr Newton's modelling produced peak flood levels that were on average 0.06 metres lower than those surveyed by Mr Cork.³²²
224. Given this slight difference, Dr Newton considered that his model was in good agreement with peak survey levels and accordingly, was appropriately validated.³²³

Validation to observed flow velocities

225. Dr Newton also considered the observations made by eyewitnesses as to velocity of the floodwaters. In particular, Dr Newton identified a number of eyewitnesses that observed floodwater velocities ranging from 60 to 100 kilometres per hour.³²⁴
226. Dr Newton developed for estimating flow velocities using available video footage of the 10 January 2011 flood. The method involved the visual tracking of debris in those videos – that is, observing the path of an item of debris, estimating the travel distance and dividing that travel distance by the length of time it took for the debris to travel.³²⁵ In Dr Newton's view, this method was not precise but allowed him to estimate velocities within an accuracy of +/- 30 per cent.³²⁶
227. Dr Newton made estimates of flood velocity across eight videos of the flooding on 10 January 2011.³²⁷ The result of that analysis is set out in Figure C44³²⁸ below.

Video No.	Location	Video Source	Distance travelled (metres)	Time (seconds)	Velocity (m/s)	Velocity (km/hr)
1	Kapernicks Bridge	Ten News Aerials - 10 January 2011 - VTS_01_1.VOB	35	7	5.0	18
2	1347 Gatton-Helidon Rd	Nine - Grantham - 10 January 2011 - Flood Aerials - VTS_01_1.VOB	40	33	1.2	4
3	1347 Gatton-Helidon Rd	Ten News Aerials - 10 January 2011 - VTS_01_1.VOB	18	22	0.8	3
4	46 Railway St	Nine - Grantham - 10 January 2011 - Flood Aerials - VTS_01_1.VOB	12	9	1.3	5
5	32 Railway St	VIDEO 3.IMG_0197.MOV (Frank King)	30	9	3.3	12
6	44-50 Railway St	Frank King video 3.WMV	100	30	3.3	12
7	12 Anzac Ave	Nine - Grantham - 10 January 2011 - Flood Aerials - VTS_01_1.VOB	8.2	2	4.1	15
8	20 Anzac Ave	Nine - Grantham - 10 January 2011 - Flood Aerials - VTS_01_1.VOB	47	11	4.3	16

Figure C44: Estimates of flood velocities.

Source: Exhibit 166, Dr David Newton, *January 2011 flood in Grantham Supplementary Report 1*, 17 August 2015 [p30: Table 5.1].

228. Dr Newton subsequently compared the result of that analysis to the simulated flow velocities from his model. In Dr Newton's view, the range of velocities observed (between 0.8 to 5.0 metres per second (or three to 18 kilometers per hour)) were generally consistent with the flow velocities simulated in Dr Newton's model.³²⁹
229. Dr Newton also prepared an animation showing the results of his analysis of flood velocities. That animation file accompanied his report.³³⁰

Dr Newton's assessment of the impact of the Grantham quarry

230. In order to assess the impact of the Grantham quarry, Dr Newton developed a further two modelled scenarios:

- a) a no breach scenario; and
- b) a pre-quarry scenario.

Additional scenarios

231. Dr Newton developed the no breach scenario using the same parameters as his model, save that it assumed there was no breach to the western embankment and the bund along the top of that embankment during the 10 January 2011 flood.³³¹
232. The pre-quarry scenario was also developed using the same parameters, save in respect of the terrain of the quarry pit. In this respect Dr Newton undertook two steps:
- a) Dr Newton made an assessment of the pre-quarry terrain in the quarry pit; and
 - b) Dr Newton replaced the modelled terrain of the quarry pit with his assessment of the pre-quarry terrain.
233. As to the first step, Dr Newton considered the work that had been done for Dr Jordan's report to assess the pre-quarry topography. Dr Newton identified that this work included a digital elevation model (DEM) of the pre-quarry topography over the area of the quarry pit, which was based on an analysis of aerial images from 13 May 1982.³³² As the DEM was derived from actual data across the pit footprint, Dr Newton adopted the DEM as representing pre-quarry conditions across the site.³³³
234. As to the second step, Dr Newton used the DEM to remove the quarry pit and existence of the western embankment and bund in his model and replace it with the Dr Jordan's pre-quarry assessment.³³⁴

Methods of Assessment

235. After developing the additional scenarios, Dr Newton conducted:
- a) an assessment of impacts on peak flood level and velocity; and
 - b) an assessment of the impacts on the time of initial inundation and rate of rise.

Assessment of impacts on peak flood level and velocity

236. To consider the impacts on peak flood level and velocity, Dr Newton compared the modelling outcomes of:³³⁵
- a) the late/fast breach scenario to the pre-quarry scenario;
 - b) the no breach scenario to the pre-quarry scenario; and
 - c) the late/fast breach scenario to the no breach scenario.

237. The first two comparisons provided an indication of the effect of the quarry pit (whether the bund/western embankment breached or not) on peak flood levels and velocities, while the third comparison provided an indication of the effect of the breach and erosion of the quarry bund/western embankment on the peak flood levels and velocities. Dr Newton chose to only compare the late/fast breach scenario as this was expected to produce the greatest impacts.³³⁶
238. The results of that analysis revealed that:³³⁷
- a) compared to what would have occurred if the quarry pit had not existed (the pre-quarry scenario), the breach to the western embankment and bund (the late/fast breach scenario) would have:
 - (i) increased flood levels along the Lockyer Creek main channel downstream of the Grantham quarry by about 0.2 metres;
 - (ii) increased flood levels upstream of the Grantham quarry by up to about 0.2 metres;
 - (iii) reduced water levels and velocities on the northern floodplain immediately downstream of the meander bend where the Grantham quarry is located; and
 - (iv) had virtually no impact on peak flood levels or velocities in Grantham;
 - b) compared to what would have occurred if the quarry pit had not existed (the pre-quarry scenario), the western embankment and bund with no breach would have:
 - (i) increased flood levels along the Lockyer Creek main channel downstream of the Grantham quarry by up to about 0.2 metres;
 - (ii) increased flood levels upstream of the Grantham quarry by up to about 0.4 metres;
 - (iii) had a relatively small impact on flow velocities in the vicinity of the meander bend, but little impact elsewhere;
 - (iv) reduced peak water levels on the northern side of the floodplain downstream of the Grantham quarry;
 - (v) reduced peak water levels on the northern side of the railway embankment; and
 - (vi) slightly reduced peak flood levels in Grantham; and
 - c) compared to what would have occurred if the no breach scenario, the breach to the western embankment and bund (late/fast breach scenario) would have:
 - (i) increased flood levels across the Lockyer Creek floodplain downstream of the Grantham quarry by more than 0.01 metres but less than 0.05 metres (a maximum flood level increase in Grantham of about three centimetres);
 - (ii) reduced flood levels for a distance of about two kilometres upstream of the Grantham quarry by more than 0.1 metres;
 - (iii) increased upstream flow velocities by up to about one metre per second; and
 - (iv) had a relatively small impact on flow velocities across the floodplain downstream of the Grantham quarry and through Grantham.

Assessment of the impacts on initial inundation and rate of rise

239. To consider the impacts on initial inundation and rate of rise, Dr Newton examined the simulated water levels for all modelled scenarios at nine separate reporting locations. Dr Newton chose those locations as they provided an indication of the range of impacts observed across the floodplain downstream of the Grantham quarry through Grantham.³³⁸

240. Those locations were as follows:³³⁹

- a) Location A – Dorrs Road and Gatton-Helidon Road Intersection;
- b) Location B – 32 Dorrs Road;
- c) Location C- 60 Dorrs Road;
- d) Location D – Charles Road and Gatton-Helidon Road intersection;
- e) Location E – 17 Citrus Street;
- f) Location F – Citrus Street and Gatton-Helidon Road intersection;
- g) Location G – 1347 Gatton-Helidon Road;
- h) Location H – 7 William Street; and
- i) Location I – 17 Harris Street.

241. Each of those locations was also marked on a figure prepared by Dr Newton, a copy of which is produced in Figure C45 below.³⁴⁰

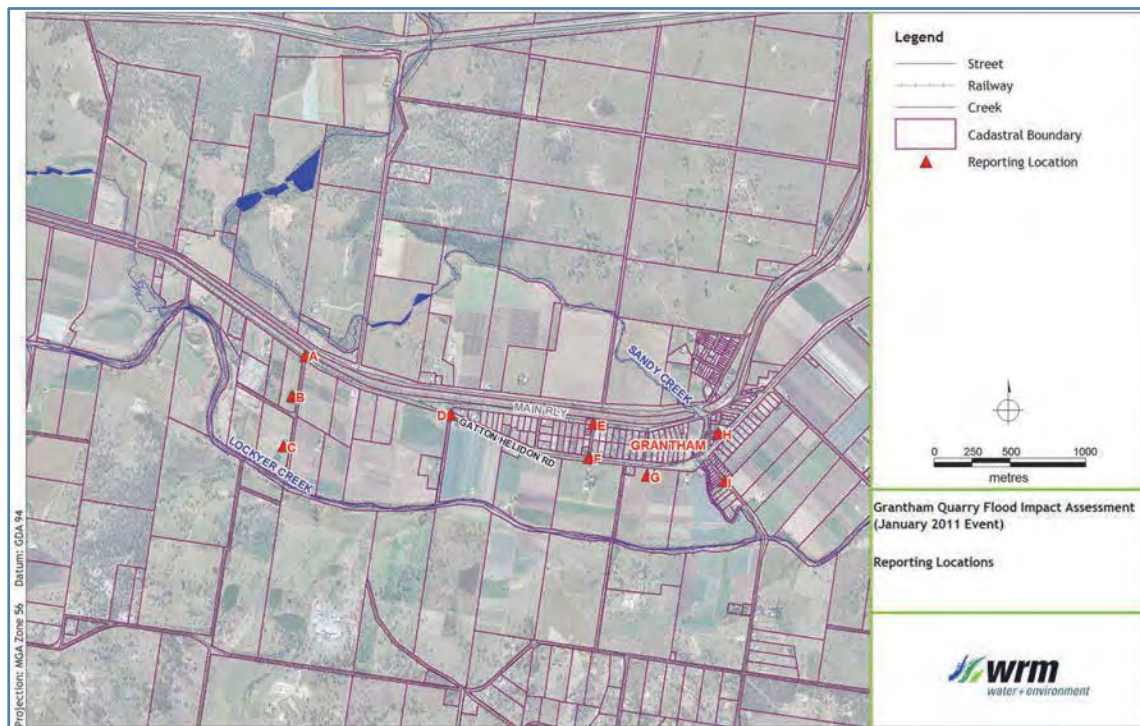

Figure C45: Reporting locations.

Source: Exhibit 166, Dr David Newton, *January 2011 flood in Grantham Supplementary Report 1*, 17 August 2015 [p40: Figure 6.1].

242. Dr Newton then compared each of the modelled scenarios by the use of a table which showed:³⁴¹

- a) the time at which the water level at each location reached a depth of 0.1 metres (which, in Dr Newton's opinion, reflected the time of the onset of flooding);
- b) the time at which the water level at each location reached a depth of one metre (which, in Dr Newton's opinion, indicated the onset of high hazard flooding);

- c) the time difference at each location between a depth of 0.1 metres and one metre; and
- d) the time difference (between fastest and slowest, earliest and latest) across all scenarios at each location.

243. A copy of that table is reproduced at Figure C46.

Reporting Location	Address	Time to reach 0.1 m depth (PM on 10 January 2011)					Maximum Time Difference (minutes)	Time to reach 1 m depth (PM on 10 January 2011)					Maximum Time Difference (minutes)	Duration from 0.1 m to 1 m depth (minutes)					
		No Breach	Late/ Fast Breach	Late/ Slow Breach	Early/ Slow Breach	Pre-quarry		No Breach	Late/ Fast Breach	Late/ Slow Breach	Early/ Slow Breach	Pre-quarry		No Breach	Late/ Fast Breach	Late/ Slow Breach	Early/ Slow Breach	Pre-quarry	Maximum Time Difference (minutes)
A	Dorrs Road and Gatton-Helidon Road Intersection	4:09:37	4:06:39	4:06:44	4:06:04	4:03:57	5.7	-	-	-	-	-	-	-	-	-	-	-	-
B	32 Dorrs Road	4:07:11	4:04:09	4:05:09	4:03:27	4:02:10	5.0	4:09:56	4:06:55	4:07:22	4:06:30	4:04:37	5.3	2.7	2.8	2.2	3.0	2.5	0.8
C	60 Dorrs Road	4:34:56	4:30:31	4:29:43	4:30:43	4:30:24	5.2	-	-	-	-	-	-	-	-	-	-	-	-
D	Charles Road and Gatton-Helidon Road Intersection	4:20:09	4:17:11	4:18:01	4:17:05	4:15:11	5.0	4:22:17	4:19:11	4:19:23	4:18:45	4:17:13	5.1	2.1	2.0	1.4	1.7	2.0	0.7
E	17 Citrus Street	4:17:17	4:15:32	4:16:14	4:15:21	4:16:11	1.9	4:20:49	4:18:46	4:19:19	4:18:34	4:19:19	2.2	3.5	3.2	3.1	3.2	3.1	0.4
F	Citrus Street and Gatton-Helidon Road Intersection	4:12:18	4:11:16	4:11:23	4:11:15	4:11:16	1.0	4:20:51	4:18:45	4:19:22	4:18:33	4:19:29	2.3	8.5	7.5	8.0	7.3	8.2	1.2
G	1347 Gatton-Helidon Road	4:15:20	4:14:21	4:14:30	4:14:22	4:14:26	1.0	4:24:08	4:22:01	4:22:27	4:21:50	4:22:35	2.3	8.8	7.7	7.9	7.5	8.2	1.3
H	7 William Street	4:01:27	4:01:27	4:01:27	4:01:32	4:00:50	0.7	4:25:43	4:24:02	4:24:29	4:23:54	4:24:24	1.8	24.3	22.6	23.0	22.4	23.6	1.9
I	17 Harris Street	4:13:08	4:12:48	4:13:01	4:13:02	4:13:01	0.3	4:32:10	4:29:34	4:29:49	4:29:19	4:29:23	2.9	19.0	16.8	16.8	16.3	16.4	2.7

Figure C46: Predicted timing and rates of rise for modelled scenarios.

Source: Exhibit 19, Dr David Newton, *Impact of the Grantham Sand quarry on the January 2011 Flood in Grantham*, 3 July 2015 [p51: Table 6.1]

244. The results of that comparison revealed the following:³⁴²

- a) the no breach scenario caused the latest time of inundation to 0.1 metres at all locations save for 7 William Street, where it was slightly faster than under the early/slow breach scenarios;
- b) the no breach scenario rose from 0.1 metre to one metre the slowest at all locations save for 32 Dorrs Road, where the early/slow breach scenario results in the slowest rate of rise;
- c) the pre-quarry scenario resulted in the earliest time of inundation to 0.1 metre at the majority of locations; and
- d) the time of rise from 0.1 metre to one metre for the pre-quarry scenario was within 1.2 minutes of the fastest and slowest rate of rise observed at all locations and across all other scenarios.

Overall assessment of the impact of the Grantham quarry

245. Having regard to the results above, Dr Newton concluded that while the results varied with location across the floodplain:

- a) the existence of the Grantham quarry had a relatively small effect on peak flood level, flow velocity and rate of rise;³⁴³
- b) at a number of locations, compared to the pre-quarry scenario, the existence of the Grantham quarry:³⁴⁴
 - (i) slightly reduced the peak flood levels by a few centimetres; and
 - (ii) delayed the initial inundation of Grantham by a few minutes;

- c) the breach to the western embankment and bund did not significantly change peak flood levels or velocities in Grantham. In Dr Newton's view, one of the reasons for this was that the large storage volume of the quarry pit attenuated the flood flow after it passed through the breach before it spread out over the floodplain towards Grantham;³⁴⁵ and
 - d) compared to the no breach scenario, the breach to the western embankment and bund resulted in floodwaters in Grantham rising a few minutes earlier than if the western embankment had not been breached.³⁴⁶
246. Based on the above, Dr Newton's opinion was that neither the Grantham quarry nor the breach to the western embankment and bund caused or materially contributed to the flooding in Grantham³⁴⁷. Further, given the observed limited impact on peak flood levels and velocities, Dr Newton considered that the existence of the Grantham quarry did not have a material impact on the damage caused by the flooding at Grantham.³⁴⁸

Summary of Conclusions reached by expert hydrologists

247. In summary, the expert hydrologists identified three factors that may have contributed to the flooding in Grantham:
- a) the Grantham quarry;
 - b) the Grantham sand plant; and
 - c) the railway embankment.
248. As to the Grantham quarry:
- a) all of the expert hydrologists agreed that the most likely impact was to delay the onset of inundation in Grantham by a few minutes. This delay was associated with the time taken to fill the quarry pit following the breaches to the western embankment and bund;
 - b) all of the expert hydrologists agreed that the Grantham quarry did not affect the flood hazard in Grantham on 10 January 2011. In this respect, Dr Macintosh and Mr Szyrkarski observed that across all of Dr Macintosh's modelled scenarios, the flood intensity exceeded over 2m²/s. In Mr Szyrkarski's opinion, flood intensity of 2m²/s is an indicator of extreme flood hazard;
 - c) Dr Macintosh and Mr Szyrkarski agreed that:
 - (i) while the western embankment and bund was in place, it operated to temporarily restrict the flow of water upstream of the Grantham quarry;
 - (ii) this temporary constriction increased the flood levels to the west of the western embankment and bund by up to 0.2 metres;
 - (iii) the effect of the increase in flood levels was minimal and was confined to the properties surrounding the Grantham quarry, because any contribution to flood flows was dissipated as the flood flows travelled across the flood plain and through the Lockyer Creek;
 - d) Dr Macintosh and Mr Szyrkarski agreed that the Grantham quarry did not have any impact on the manner in which the flooding occurred. That is, both Dr Macintosh and Mr Szyrkarski considered that across all of Dr Macintosh's modelled scenarios (and consistent with eyewitness accounts), the flooding occurred in three stages as described above;
 - e) Dr Macintosh considered that the most likely impact on evacuation routes was to delay the time of closure by up to two minutes;

- f) Mr Szylkarski considered that the Grantham quarry slightly increased the rate of rise of flood flows to the peak of the flood by about three minutes faster. The net result however was that the peak of the flood flows occurred at about the same time; and
 - g) Dr Newton considered that at some locations in Grantham, the Grantham quarry also slightly reduced the peak flood levels by a few centimetres.
249. Dr Macintosh considered that the most likely effect of the existence the Grantham sand plant (as opposed to the Grantham quarry) was to delay the time of inundation of the Grantham area by one to three minutes.
250. As to the railway embankment, Dr Macintosh considered that the most likely effect was to slightly increase maximum flood depths, intensities and velocities but not to increase those factors so substantially as to affect overall flood hazard. That is, the railway embankment did not affect the overall flood hazard associated with the flooding in Grantham that remained in the extreme.
251. Based on the above, the collective views of the experts were that:
- a) none of the factors identified caused or materially contributed to the flooding in Grantham;
 - b) given the observed limited impact on peak flood levels and intensity, the Grantham quarry did not have a material impact on the flood hazard or damage that occurred in Grantham during the flood; and
 - c) the Grantham quarry did not have a material impact on the evacuation of Grantham on 10 January 2011.

Issues raised regarding the hydraulic modelling

252. The Commission also received a number of submissions raising issues regarding the work performed by the expert hydrologists. These submissions were made by parties with leave to appear and by other interested persons without leave to appear.

Submissions by parties with leave to appear

253. The submissions raised nine separate issues to be considered when assessing the conclusions reached by the experts.

First Issue – The hypothetical no quarry scenario did not occur³⁴⁹

254. During the hearing on 19 August 2015, it was suggested to Dr Macintosh that the modelling undertaken was limited because it relied upon a scenario that did not occur – namely, that the January 2011 flood without a quarry has never happened. The suggestion was made that if it did occur then Dr Macintosh could expect that his pre-quarry scenario would be a bit different and calibrations would need to be made to take into account eyewitness observations.³⁵⁰
255. Dr Macintosh did not accept this and contended that his modelling was not limited by the fact that the no quarry scenario did not occur.³⁵¹ The process used by Dr Macintosh for the alternative scenarios was to make a well-defined change to the most likely scenario which had been well calibrated. This meant that the assessment of the degree of difference between the scenarios was fairly accurate and reliable.³⁵²
256. Mr Szylkarski supported the accuracy of Dr Macintosh's modelling in examining the differences between the most likely scenario and other scenarios, such as the no quarry scenario.³⁵³

257. Given the views of Dr Macintosh and Mr Szylkarski, I consider that Dr Macintosh's modelling was not limited by the fact the no quarry scenario did not occur.

Second Issue – the topography for the Pre-quarry scenario was unreliable

258. For the purposes of their no quarry scenarios, Dr Macintosh and Dr Newton modified the topography in the quarry pit to match their assessments of the pre quarry terrain.

259. An issue raised with respect to the assessment of Dr Macintosh was that it relied upon Mr Starr's opinion as to the south-east corner of the quarry pit area. It was suggested that Mr Starr's opinion was unreliable because it did not rely upon LiDAR surveys but involved an extrapolation beyond available data points, which meant other interpretations of that area may be possible.³⁵⁴

260. It was not possible for Mr Starr to use a LiDAR survey to assess the pre-quarry terrain because LiDAR is a recent innovation and was not available in the late 1970s or earlier 1980s when quarrying began.

261. The methodology used by Mr Starr to determine the pre-quarry terrain involved an analysis of:³⁵⁵

- a) a 1982 aerial photograph taken over the Grantham quarry area (the earliest aerial photograph that Mr Starr was able to locate of the Grantham quarry area);
- b) the results of excavated test pits in the Grantham quarry which included an analysis of the soil contained in those test pits; and
- c) a 1981 survey plan of the Grantham quarry area, which included, relevantly, the surveyed heights in the southeast corner of the Grantham quarry pit.

262. For the reasons given in Appendix A, Mr Starr's opinion is sound and reliable and there is no reason to doubt that it provides an accurate representation of the pre-quarry terrain. I accept Mr Starr's opinion as to the pre-quarry terrain. It follows that there was no issue with Dr Macintosh relying upon Mr Starr's assessment of the pre-quarry terrain.

Third Issue - the inflow hydrograph at Lockyer Creek was uncertain

263. Dr Macintosh and Dr Newton derived their own rating curves for the Lockyer Creek at the Helidon gauge. The experts then used those rating curves to derive an inflow hydrograph for Lockyer Creek, which was then used as an input for their models.

264. A submission was made that Dr Macintosh's inflow hydrograph was uncertain because his rating curve differed from the rating curve that was used for the Dr Jordan's report. The submission was to the effect that Dr Macintosh's inflow hydrograph was unreliable because two very competent and qualified hydrologists (Dr Macintosh and Dr Jordan) came to a different view on rating curves.³⁵⁶

265. As I explained above, the inflow hydrograph for Lockyer Creek was used as the upstream boundary condition for Dr Macintosh's model.³⁵⁷ If the inflow hydrograph was invalid then the upstream boundary condition of the model would also be invalid and, as Mr Szylkarski noted, the model would produce results that differed from the peak survey levels. But in fact there was a close correlation between the flood levels modelled by Dr Macintosh and the peak surveyed flood levels.³⁵⁸ For this reason, Mr Szylkarski considered Dr Macintosh's rating curve and the upstream boundary condition for his model to be accurate and reliable.³⁵⁹

266. Dr Macintosh's inflow hydrograph for the Lockyer Creek was accurate and reliable. I do not accept the submission that there is any meaningful uncertainty about this.

Fourth issue - The inflow hydrograph at Gatton was low

267. An issue was raised that there were unsatisfactory explanations given as to why the inflow hydrograph at Gatton was so low.³⁶⁰ This submission refers to the evidence of Dr Macintosh³⁶¹ to the effect that:
- a) Dr Macintosh considered that there was a large volume of water that passed through Grantham during the 10 January 2011 flood;
 - b) if this was correct then there would be a major impact on the water levels at Gatton downstream of Grantham;
 - c) the inflow hydrograph for Gatton was quite low, which did not appear to demonstrate a major impact on water levels; and
 - d) Dr Macintosh did not provide a satisfactory explanation for why the inflow hydrograph at Gatton was so low.
268. This submission is inaccurate. As I addressed in Chapter 5, Gatton experienced a double peak flood, first on 10 January 2011 and then on 11 January 2011. However, as Dr Macintosh explained in his evidence with respect to the 10 January 2011 flood, *“as a flood moves down a catchment, it tends to lower and peak, and spread out in its breadth, so there’s a natural dispersion of the flood as we’re coming through. At Helidon, the flows were in a steep water, steep, confined and a very big peak. As soon as we move out past Kapernick’s Bridge, the flow starts to spread out and from there downwards, this peaking flood, it reduces in magnitude. And so by the time you get to Gatton, it could well have dissipated out quite substantially”*.³⁶²
269. As I noted in Chapter 5, the flooding of Gatton on 11 January 2011 was primarily due to significant rainfall in catchments that were downstream of Grantham, hence the differences between the flooding that occurred on 10 January 2011 and 11 January 2011 in Grantham and Gatton.
270. I do not consider that Dr Macintosh’s explanation is unsatisfactory. In any event, I do not consider that a low water level observed at Gatton had any significance for Dr Macintosh’s assessment of the flooding through Grantham. If that were the case then Dr Macintosh’s modelling would not have matched with eyewitness observations and peak survey flood levels for the 10 January 2011 flood.

Fifth Issue – that the no quarry scenario should not have been used as a reference case

271. A submission was made that what should have been modelled was what would have happened if:³⁶³
- a) there were no bunds; and
 - b) there were plant or operations for the Grantham sand plant and if the plant area was reduced back to natural ground level; but
 - c) there was a quarry pit.
272. The effect of this submission is that there should have been modelling of what would have happened if there was no Grantham sand plant but somebody had simply dug a giant hole in the ground and removed all the material that was excavated.
273. Dr Macintosh modelled a no quarry scenario, a no Grantham sand plant scenario and the no levee scenario in which the bunds and material surrounding the quarry pit were removed but the quarry pit remained.³⁶⁴ Dr Macintosh prepared hydrographs comparing the results of those scenarios against the most likely scenario.³⁶⁵ Based on those scenarios, it is apparent that there would be no material effect on the flooding of Grantham or the surrounding properties if the entire Grantham sand plant was removed but a pit was still excavated. In any case, this hypothetical case is entirely unreal because the sand plant pre-dated the quarry pit.

Sixth Issue – That the modelling did not model debris and hyperconcentrated flows

274. Both Dr Macintosh and Dr Newton used a TUFLOW hydraulic model to assess the flooding that occurred on 10 January 2011. An issue was raised in submissions that this type of model cannot model debris flows or hyperconcentrated flows.³⁶⁶
275. During the hearings, Dr Macintosh and Mr Szykarski gave the following evidence concerning debris flows and hyperconcentrated flows generally:
- a) a debris flow was a flood flow made up of more than 50 per cent sediment;³⁶⁷
 - b) a hyperconcentrated flow was made up of about 30 to 40 per cent sediment and could be best described as like a tailing mud;³⁶⁸
 - c) both debris flows and hyperconcentrated flows moved faster than a flood flow without as much sediment;³⁶⁹ and
 - d) a hyperconcentrated flow would not drain away in the same way as in a typical flood – there would not be free drainage because at some point during the flood, the flow would freeze at certain depth leaving material sitting all over the flood plain.³⁷⁰
276. A submission was made that debris flows and hyperconcentrated flows were present during the 10 January 2011 flood. There were two reasons given in support of that submission:
- a) that multiple eyewitness accounts described the appearance of floodwater as “muddy like a thickshake” and “filled with lots of debris”; and significant amounts of debris, sediment and sludge left at their properties;³⁷¹ and
 - b) as there was 36,780 metres of material removed from the western embankment, that material along with material from stockpiles surrounding the Grantham quarry would have changed the viscosity of the water.³⁷²
277. Dr Macintosh and Mr Szykarski were asked to consider whether debris flows and hyper-concentrated flows were observed during the 10 January 2011 flood. Both Dr Macintosh and Mr Szykarski rejected this possibility as this type of flow would have resulted in the following effects which were not observed in Grantham:
- a) a phenomenal amount of leftovers and a substantial amount of sediment and debris left around;³⁷³
 - b) large deposits of mud or sludge over the entire floodplain covering everything.³⁷⁴
278. Mr Szykarski was also asked to consider evidence given by residents that the water appeared to look like a “chocolate thickshake”. Mr Szykarski considered that this description was consistent with floodwaters generally rather than with a hyper concentrated flood flows.³⁷⁵
279. As to the second reason, there were 36,780 metres of material removed from the western embankment of the Grantham quarry. In the opinion of Dr Macintosh, between 2 pm and 8 pm on 10 January 2011, there were six gigalitres of water that passed through Grantham and 32 gigalitres of water that passed through the flood plain.³⁷⁶ Even if all of the material removed from the western embankment had been carried in the six gigalitres of water that passed through Grantham, that material would have constituted less than 1 per cent of the flow. This is far below the 30 to 40 per cent of sediment estimated for a hyper-concentrated flow.
280. In my opinion there were neither hyperconcentrated flows nor debris flows during the 10 January 2011 flood of Grantham. It follows that neither Dr Macintosh’s nor Dr Newton’s modelling was affected by a failure to model these flows.

Seventh Issue – That the modelling did not model steep fronted waves

281. As indicated in Mr Szylkarski's report of February 2015 to The Australian, one of the limitations of the TUFLOW hydraulic model is an inability to model steep fronted waves.³⁷⁷ Given Dr Macintosh's and Dr Newton's use of the TUFLOW model, an issue was raised that the modelling work undertaken was deficient because it did not account for steep fronted waves.³⁷⁸
282. Mr Szylkarski raised the issue of steep fronted waves as a matter that might be relevant if there were a mismatch between the modelled outcomes and eyewitness observations. However, in Mr Szylkarski's view, there was a close corroboration between Dr Macintosh's modelling outcomes and eyewitness observations and therefore it was not necessary to model steep fronted waves.³⁷⁹
283. I accept Mr Szylkarski's view as to this matter. It was not necessary to model steep fronted waves and they could not affect Dr Macintosh's findings.

Eighth Issue – That the modelling underestimated the influence of waves, viscosity and debris at properties closest to the Grantham quarry

284. A further submission was made to the effect that Dr Macintosh's modelling may understate the influence of the floodwaters closest to the Grantham quarry.³⁸⁰ That was said to be because the modelling did not include a wave effect and did not take into account the viscosity of the floodwaters and did not take into account the effect of debris.
285. Many witnesses described seeing waves in the floodwater. For example, Ms Spierling described the south-western overbank flow, which was the water that came from the south, as being like a wave you see at the beach as it is rolling in. However, there is no evidence that there was a wave effect caused by the Grantham quarry or the collapse of the bunds. Rather, the waves appear to be an ordinary part of water surging across the landscape. There is no evidence that waves were worse close to the quarry. There is no evidence that waves in the water would have any meaningful impact on the damage caused by the huge volume of water surging across the landscape.
286. As I explained, Mr Szylkarski had raised the possibility of needing to model steep-fronted waves because that might be a possible explanation for an apparent inconsistency between the modelled timing and water levels and the actual timing and water levels in the Jordan report. However, Mr Szylkarski did not think that was necessary for Dr Macintosh's modelling because of the close correlation between the model and what in fact occurred.
287. The opinion of Dr Macintosh and Mr Szylkarski is that there were no hyper-concentrated or debris flows during the flooding in Grantham on 10 January 2011. I have accepted those opinions. There was no evidence to the contrary.
288. In addition, there was no evidence that a significant proportion of the material that was scoured from the western embankment was directed towards the properties closest to the Grantham. There was no evidence that this material was even washed out of the quarry pit. There was no evidence or explanation for how it would be washed towards those properties when the majority of the flow out of the quarry pit was to the south east back to the Lockyer Creek. There was no evidence that this material would have had a meaningful impact on the damage caused by the floodwaters. The premise of this hypothesis is that Dr Macintosh's modelling understates the capacity of the floodwaters to damage property but the flows as modelled by Dr Macintosh were sufficient to cause the damage that occurred.
289. Dr Macintosh considered the presence of debris in the 10 January 2011 floods as described by eyewitnesses and depicted in photographs and videos (including those showing debris accumulations upstream of the Grantham Quarry)³⁸¹. Dr Macintosh's view was that the amount of debris observed was relatively small in concentration when compared to the intensity of the flow and not sufficient to affect the net depth, intensity or timing of the flooding.³⁸²

For a particular object, such as a crane, debris accumulating against the object might effectively increase the surface area of the object against which the water would press.³⁸³ But that is a different issue from whether the modelled flows were sufficient to explain the damage to property that occurred. They were.

290. I do not accept that Dr Macintosh's modelling underestimates the impact of the floodwaters on the properties closest to the Grantham quarry. No expert supported that hypothesis.

Ninth Issue – That the modelling did not directly match some eyewitness observations

291. The final issue raised was that the modelling did not directly match some eyewitness observations.³⁸⁴

292. As Dr Macintosh explained, the modelling is a schematisation of reality.³⁸⁵ Slight inconsistencies between the modelled outcomes and the eyewitness observations are to be expected and they do not mean that the modelling is unreliable.

293. In any event, the modelling is accurate and reliable in assessing the effect of changes, such as the removal of the quarry and assessing whether a particular feature has caused, contributed or materially influenced the flooding requires an assessment of the effect of changes to such features.

Conclusions regarding issues raised by parties with leave to appear

294. Having regard to the above, I do not consider that any of the issues raised substantively affect the findings of the experts. I accept the experts' opinions as reliable.

Submissions by interested persons without leave to appear

295. Some interested persons without leave to appear made submissions to the Commission in relation to the modelling and the expert opinions. One submission made was that the rainfall in the Lockyer Creek catchment on 11 January 2011 was the same, if not more than the rainfall on 10 January 2011. It was submitted that the modelling did not consider this and why there was not a repeat of the same flooding on 11 January 2011³⁸⁶. This issue was considered and an explanation was given by Dr John Macintosh his Second Supplementary Material.³⁸⁷ I have explained the differences between the rainfall on 10 January 2011 and on 11 January 2011 in Chapter Five.

296. The submission also raised some additional matters as to why the modelling was wrong:

- a) the modelling did not consider the presence of hydraulic jumps that may have occurred at some stage along the Lockyer Creek floodplain;³⁸⁸
- b) the experts did not consider the saturation of the soil in the Lockyer Valley and the implications of that for the rainfall run off rate assumed in the modelling;³⁸⁹
- c) the modelling assumed that rainfall runoff was steady and uniform but that assumption could not be applied to rapidly varied flow as occurred in the Grantham flood;³⁹⁰
- d) Dr Macintosh's modelling relied on a number of parameters on which he had to exercise his own judgment because he had no actual data;³⁹¹
- e) Dr Macintosh's modelling assumed a roughness coefficient that was uniform across the entire floodplain;³⁹²
- f) Dr Macintosh's modelling did not adequately consider the debris and the effect of the floodwaters of debris at Kapernick's Bridge;³⁹³

- g) the modelling did not show a venturi effect. This effect was created when the water back flowing up Sandy Creek flowed through the bridge;³⁹⁴
 - h) the modelling did not show jet stream flows and the continuous momentum currents that they would have generated as a result of the banking back behind the western embankment followed by sudden sectional landslides of that embankment;³⁹⁵
 - i) the modelling did not show zonal jet streams that were directed towards Grantham which emanated from infill of water into the quarry and passed through the haul road exit and between two spoil heaps;³⁹⁶
 - j) the modelling did not consider the surge of water generated when the floodwaters overtopped the western embankment. This surge created a force far in excess of that possible from either the floodwater or the failing embankment on its own;³⁹⁷
 - k) Dr Macintosh's modelling does not explain why mud was found on the top of the roof ridge a house at 1617 Gatton-Helidon Road, which was estimated as being four to five metres from ground level;³⁹⁸
 - l) Dr Macintosh's modelling does not show floodwaters 15 feet deep at Gatton-Helidon Road, which was the estimate of Mr and Ms Arndt;³⁹⁹
 - m) notwithstanding Dr Macintosh's opinion to the contrary, Dr Macintosh's modelling is not consistent with a 12 tonne crane being moved near a house at 1617 Gatton-Helidon Road;⁴⁰⁰ and
 - n) Dr Macintosh's modelling is not consistent with the movement of an Escort car during the flood and the damage caused to that car;⁴⁰¹
 - o) Dr Macintosh's modelling was based on the main breach in the western embankment being eroded on 10 January 2011 but some people do not believe that erosion occurred until after the flood, perhaps on the next day.⁴⁰²
297. The premise of these submissions is that the flooding was different, either generally or in particular areas, to that which was modelled by the experts. The difficulty is that the modelling closely correlates with what was observed and recorded by eyewitnesses and the objective data as to flood and water levels. It follows that the ultimate effect of those submissions is to suggest that the eyewitnesses' accounts and their records, and the data as to flood and water levels, is inaccurate. There is no reason to consider that all of the eyewitness accounts and records and the objective data is inaccurate. On the contrary, I regard the witnesses' evidence of the flood behavior to be accurate.
298. In addition, the expert opinions, while informed by modelling, do not present that modelling as the fact. The experts use the modelling as a tool to test and explain what occurred on 10 January 2011 and the factors that contributed to what occurred. The further submissions that I have summarised do not present a direct or adequate explanation for why the totality of that testing and explanation by the experts is incorrect.
299. For the reasons I have explained, I consider that both the modelling and opinions of the experts are reliable.

- ¹ Exhibit 144, Dr John Macintosh, *Report to Grantham Floods Commission of Inquiry – Expert Hydrology Report 10 January 2011 – Circumstances and Contributing Factors*, 11 August 2015 [p38: para 88]; Transcript, 17 August 2015, Dr John Macintosh [p1110: line 31 - p1111: line 2].
- ² Exhibit 144, Dr John Macintosh, *Report to Grantham Floods Commission of Inquiry – Expert Hydrology Report 10 January 2011 – Circumstances and Contributing Factors*, 11 August 2015.
- ³ Exhibit 144, Dr John Macintosh, *Report to Grantham Floods Commission of Inquiry – Expert Hydrology Report 10 January 2011 – Circumstances and Contributing Factors Supplementary Material*, 17 August 2015.
- ⁴ Exhibit 304, Dr John Macintosh, *Report to Grantham Floods Commission of Inquiry – Expert Hydrology Report 10 January 2011 – Circumstances and Contributing Factors Supplementary Material No. 2*, 3 September 2015
- ⁵ Transcript, 17 August 2015: Dr John Macintosh [p1111: line 23 - p1112: line 17].
- ⁶ Exhibit 144, Various animation files produced by Dr John Macintosh; Exhibit 304, Various animation files produced by Dr John Macintosh.
- ⁷ Transcript, 17 August 2015: Dr John Macintosh [p1110: line 5 - p1175: line 19]; 18 August 2015: Dr John Macintosh [p1181: line 4 - p1236: line 20]; 19 August 2015: Dr John Macintosh [p1238: line 14 - p1312 line 17]; 20 August 2015: Dr John Macintosh [p1315: line 15 - p1350: line 43].
- ⁸ Exhibit 144, Dr John Macintosh, *Report to Grantham Floods Commission of Inquiry – Expert Hydrology Report 10 January 2011 – Circumstances and Contributing Factors*, 11 August 2015 [p19: para 7; p20: Figure 1.2].
- ⁹ A complete list of the eyewitness accounts provided is contained in exhibit 144, Dr John Macintosh, *Report to Grantham Floods Commission of Inquiry – Expert Hydrology Report 10 January 2011 – Circumstances and Contributing Factors Supplementary Material*, 11 August 2015 [p183 - p185: Sections A.2 to A.3 and A.5].
- ¹⁰ Exhibit 3, Sinclair Knight Merz, *Lockyer Creek Flood Risk Management Study for Lockyer Valley Regional Council*, December 2014.
- ¹¹ Exhibit 146, Dr Phillip Jordan, *Provision of Hydrological Advice to the Queensland Floods Commission of Inquiry – Assessment of Impact of Quarrying Operations on Flash Flooding in Grantham on 10 January 2011*, 16 September 2011.
- ¹² Exhibit 40, Statement of Richard Cork, 2 July 2015; Exhibit 156, Ian Rickuss MP, Flood Level Survey Plan TM153 FL 002A.
- ¹³ Exhibit 131, David Starr, *Grantham quarry – Geotechnical Investigations and Expert Opinion on Formation of Earthworks for Grantham Floods Commission of Inquiry*, 28 July 2015.
- ¹⁴ Exhibit 145, Stefan Szykarski, *Grantham and Wagner quarry Review of Flood Impact 10th January 2011 event prepared for Nationwide News Pty Ltd*, February 2015.
- ¹⁵ Exhibit 144, Dr John Macintosh, *Report to Grantham Floods Commission of Inquiry – Expert Hydrology Report 10 January 2011 – Circumstances and Contributing Factors*, 11 August 2015 [p43: paras 100 - 103].
- ¹⁶ Exhibit 144, Dr John Macintosh, *Report to Grantham Floods Commission of Inquiry – Expert Hydrology Report 10 January 2011 – Circumstances and Contributing Factors*, 11 August 2015 [p43: para 102].
- ¹⁷ Exhibit 144, Dr John Macintosh, *Report to Grantham Floods Commission of Inquiry – Expert Hydrology Report 10 January 2011 – Circumstances and Contributing Factors*, 11 August 2015 [p43: para 103].
- ¹⁸ Exhibit 144, Dr John Macintosh, *Report to Grantham Floods Commission of Inquiry – Expert Hydrology Report 10 January 2011 – Circumstances and Contributing Factors*, 11 August 2015 [p46: para 123].
- ¹⁹ Exhibit 144, Dr John Macintosh, *Report to Grantham Floods Commission of Inquiry – Expert Hydrology Report 10 January 2011 – Circumstances and Contributing Factors*, 11 August 2015 [p46: para 124].
- ²⁰ Exhibit 144, Dr John Macintosh, *Report to Grantham Floods Commission of Inquiry – Expert Hydrology Report 10 January 2011 – Circumstances and Contributing Factors*, 11 August 2015 [p55: para 151].
- ²¹ Exhibit 144, Dr John Macintosh, *Report to Grantham Floods Commission of Inquiry – Expert Hydrology Report 10 January 2011 – Circumstances and Contributing Factors*, 11 August 2015 [p55: para 151].
- ²² Exhibit 144, Dr John Macintosh, *Report to Grantham Floods Commission of Inquiry – Expert Hydrology Report 10 January 2011 – Circumstances and Contributing Factors*, 11 August 2015 [p46: para 128; p57: para 161].
- ²³ Exhibit 144, Dr John Macintosh, *Report to Grantham Floods Commission of Inquiry – Expert Hydrology Report 10 January 2011 – Circumstances and Contributing Factors*, 11 August 2015 [p55: paras 153-154].
- ²⁴ Transcript, 17 August 2015: John Macintosh [p1143: line 15 -33].
- ²⁵ Exhibit 144, Dr John Macintosh, *Report to Grantham Floods Commission of Inquiry – Expert Hydrology Report 10 January 2011 – Circumstances and Contributing Factors*, 11 August 2015 [p55: para 156 - p56: para 157].
- ²⁶ Exhibit 144, Dr John Macintosh, *Report to Grantham Floods Commission of Inquiry – Expert Hydrology Report 10 January 2011 – Circumstances and Contributing Factors*, 11 August 2015 [p15]; Transcript, 17 August 2015; John Macintosh [p1117: line 6-16].
- ²⁷ Transcript, 17 August 2015: John Macintosh [p1117: lines 6-16].
- ²⁸ Exhibit 144, Dr John Macintosh, *Report to Grantham Floods Commission of Inquiry – Expert Hydrology Report 10 January 2011 – Circumstances and Contributing Factors*, 11 August 2015 [p23: para 17].
- ²⁹ Transcript, 17 August 2015: Dr John Macintosh [p1121: lines 29-44].
- ³⁰ Exhibit 144, Dr John Macintosh, *Report to Grantham Floods Commission of Inquiry – Expert Hydrology Report 10 January 2011 – Circumstances and Contributing Factors*, 11 August 2015 [p44: para 104].
- ³¹ Exhibit 144, Dr John Macintosh, *Report to Grantham Floods Commission of Inquiry – Expert Hydrology Report 10 January 2011 – Circumstances and Contributing Factors*, 11 August 2015 [p44: para 106].
- ³² Transcript, 17 August 2015: Dr John Macintosh [p1117: lines 39-43].
- ³³ Transcript, 17 August 2015: Dr John Macintosh [p1120: lines 3- 39].
- ³⁴ Transcript, 17 August 2015: Dr John Macintosh [p1121: lines 3-27]

- ³⁵ Exhibit 144, Dr John Macintosh, *Report to Grantham Floods Commission of Inquiry – Expert Hydrology Report 10 January 2011 – Circumstances and Contributing Factors*, 11 August 2015 [p187: para 4]
- ³⁶ Transcript, 17 August 2015: Dr John Macintosh [p1124 line 10-13].
- ³⁷ Exhibit 144, Dr John Macintosh, *Report to Grantham Floods Commission of Inquiry – Expert Hydrology Report 10 January 2011 – Circumstances and Contributing Factors*, 11 August 2015 [p187 para 5 - p188 para 6].
- ³⁸ Transcript, 17 August 2015: Dr John Macintosh [p1124 line 27-38].
- ³⁹ Exhibit 144, Dr John Macintosh, *Report to Grantham Floods Commission of Inquiry – Expert Hydrology Report 10 January 2011 – Circumstances and Contributing Factors*, 11 August 2015 [p58: Table 8.1; p61: para 182].
- ⁴⁰ Exhibit 144, Dr John Macintosh, *Report to Grantham Floods Commission of Inquiry – Expert Hydrology Report 10 January 2011 – Circumstances and Contributing Factors*, 11 August 2015 [p58: Table 8.1; p61: para 183].
- ⁴¹ Exhibit 144, Dr John Macintosh, *Report to Grantham Floods Commission of Inquiry – Expert Hydrology Report 10 January 2011 – Circumstances and Contributing Factors*, 11 August 2015 [p58: Table 8.1; p61: para 183]; Transcript, 17 August 2015: Dr John Macintosh [p1125: line 26-38].
- ⁴² Exhibit 144, Dr John Macintosh, *Report to Grantham Floods Commission of Inquiry – Expert Hydrology Report 10 January 2011 – Circumstances and Contributing Factors*, 11 August 2015 [p61: para 183]; Transcript, 17 August 2015, Dr John Macintosh [p1125: lines 10-16].
- ⁴³ Exhibit 144, Dr John Macintosh, *Report to Grantham Floods Commission of Inquiry – Expert Hydrology Report 10 January 2011 – Circumstances and Contributing Factors*, 11 August 2015 [p63: para 192]; Transcript, 17 August 2015: Dr John Macintosh [p1126: lines 15-23]
- ⁴⁴ Exhibit 144, Dr John Macintosh, *Report to Grantham Floods Commission of Inquiry – Expert Hydrology Report 10 January 2011 – Circumstances and Contributing Factors*, 11 August 2015 [p63: para 192]; Transcript, 17 August 2015: Dr John Macintosh [p1125: line 40 - p1126: line 2]
- ⁴⁵ Exhibit 144, Dr John Macintosh, *Report to Grantham Floods Commission of Inquiry – Expert Hydrology Report 10 January 2011 – Circumstances and Contributing Factors*, 11 August 2015 [p3: para 193]
- ⁴⁶ Exhibit 144, Dr John Macintosh, *Report to Grantham Floods Commission of Inquiry – Expert Hydrology Report 10 January 2011 – Circumstances and Contributing Factors*, 11 August 2015 [p3: para 193]; Transcript, 17 August 2015: Dr John Macintosh [p1126: line 4-8]
- ⁴⁷ Exhibit 144, Dr John Macintosh, *Report to Grantham Floods Commission of Inquiry – Expert Hydrology Report 10 January 2011 – Circumstances and Contributing Factors*, 11 August 2015 [p63: para 195]
- ⁴⁸ Exhibit 144, Dr John Macintosh, *Report to Grantham Floods Commission of Inquiry – Expert Hydrology Report 10 January 2011 – Circumstances and Contributing Factors*, 11 August 2015 [p63: para 195]; Transcript, 17 August 2015: John Macintosh [p1126: lines 30-40]
- ⁴⁹ Exhibit 144, Dr John Macintosh, *Report to Grantham Floods Commission of Inquiry – Expert Hydrology Report 10 January 2011 – Circumstances and Contributing Factors*, 11 August 2015 [p75: para 253]
- ⁵⁰ Transcript, 17 August 2015: John Macintosh [p1158 line 6-12]
- ⁵¹ Exhibit 144, Dr John Macintosh, *Report to Grantham Floods Commission of Inquiry – Expert Hydrology Report 10 January 2011 – Circumstances and Contributing Factors*, 11 August 2015 [p76: para 256]
- ⁵² Transcript, 19 August 2015: Dr John Macintosh [p1294: lines 10-19]
- ⁵³ Transcript, 19 August 2015: Dr John Macintosh [p1294: lines 21-26]
- ⁵⁴ Exhibit 144, Dr John Macintosh, *Report to Grantham Floods Commission of Inquiry – Expert Hydrology Report 10 January 2011 – Circumstances and Contributing Factors*, 11 August 2015 [p75: para 253]; Transcript, 19 August 2015, Dr John Macintosh [p1295: line 35-39].
- ⁵⁵ Exhibit 144, Dr John Macintosh, *Report to Grantham Floods Commission of Inquiry – Expert Hydrology Report 10 January 2011 – Circumstances and Contributing Factors*, 11 August 2015 [p76: para 254]
- ⁵⁶ Exhibit 144, Dr John Macintosh, *Report to Grantham Floods Commission of Inquiry – Expert Hydrology Report 10 January 2011 – Circumstances and Contributing Factors*, 11 August 2015 [p76: para 255]
- ⁵⁷ Exhibit 144, Dr John Macintosh, *Report to Grantham Floods Commission of Inquiry – Expert Hydrology Report 10 January 2011 – Circumstances and Contributing Factors*, 11 August 2015 [p76: para 255]
- ⁵⁸ Exhibit 144, Dr John Macintosh, *Report to Grantham Floods Commission of Inquiry – Expert Hydrology Report 10 January 2011 – Circumstances and Contributing Factors*, 11 August 2015 [p76: para 256].
- ⁵⁹ Exhibit 144, Dr John Macintosh, *Report to Grantham Floods Commission of Inquiry – Expert Hydrology Report 10 January 2011 – Circumstances and Contributing Factors*, 11 August 2015 [p235]
- ⁶⁰ Exhibit 144, Dr John Macintosh, *Report to Grantham Floods Commission of Inquiry – Expert Hydrology Report 10 January 2011 – Circumstances and Contributing Factors*, 11 August 2015 [p73: para 233]
- ⁶¹ Exhibit 48, Statement of Anthony McIntosh dated 1 July 2015 [Attachment AM-3, Video 1 and Video 2].
- ⁶² Transcript, 17 August 2015, Dr John Macintosh [p 1148: lines 12-17]
- ⁶³ Exhibit 144, Dr John Macintosh, *Report to Grantham Floods Commission of Inquiry – Expert Hydrology Report 10 January 2011 – Circumstances and Contributing Factors*, 11 August 2015 [p74: para 235]
- ⁶⁴ Transcript, 17 August 2015, Dr John Macintosh [p1148: lines 9-24]
- ⁶⁵ Exhibit 144, Dr John Macintosh, *Report to Grantham Floods Commission of Inquiry – Expert Hydrology Report 10 January 2011 – Circumstances and Contributing Factors*, 11 August 2015 [p74: para 238]; Transcript, 17 August 2015, John Macintosh [p1148: lines 26 -34]
- ⁶⁶ Exhibit 28b, Statement of Wayne Douglas Lack dated 7 July 2015
- ⁶⁷ Transcript, 17 August 2015, Dr John Macintosh [p1155: line 4-17]
- ⁶⁸ Transcript, 17 August 2015, Dr John Macintosh [p1155: line 19-25]
- ⁶⁹ Transcript, 17 August 2015, Dr John Macintosh [p1155: lines 35-42]
- ⁷⁰ Transcript, 17 August 2015, Dr John Macintosh [p1155: line 45 - p1156: line 3]
- ⁷¹ Transcript, 21 July 2015, Mr Jonathan Sippel [p138: lines 8-10]
- ⁷² Exhibit 304, Dr John Macintosh, *Report to Grantham Floods Commission of Inquiry – Expert Hydrology Report 10 January 2011 – Circumstances and Contributing Factors Supplementary Material No. 2*, 3 September 2015 [p38: paras 51-53]

- ⁷³ Exhibit 131, David Starr, *Grantham quarry – Geotechnical Investigations and Expert Opinion on Formation of Earthworks for Grantham Floods Commission of Inquiry*, 28 July 2015.
- ⁷⁴ Exhibit 144, Dr John Macintosh, *Report to Grantham Floods Commission of Inquiry – Expert Hydrology Report 10 January 2011 – Circumstances and Contributing Factors*, 11 August 2015 [p66: para 201]
- ⁷⁵ Exhibit 144, Dr John Macintosh, *Report to Grantham Floods Commission of Inquiry – Expert Hydrology Report 10 January 2011 – Circumstances and Contributing Factors*, 11 August 2015 [p72: para 222]; Transcript, 17 August 2015: Dr John Macintosh [p1129 line 10 to 13]
- ⁷⁶ Exhibit 144, Dr John Macintosh, *Report to Grantham Floods Commission of Inquiry – Expert Hydrology Report 10 January 2011 – Circumstances and Contributing Factors*, 11 August 2015 [p72: para 223]
- ⁷⁷ Transcript, 17 August 2015: Dr John Macintosh [p1129: line 15-17]
- ⁷⁸ Transcript, 17 August 2015: Dr John Macintosh [p1120: line 3-4]
- ⁷⁹ Exhibit 144, Dr John Macintosh, *Report to Grantham Floods Commission of Inquiry – Expert Hydrology Report 10 January 2011 – Circumstances and Contributing Factors*, 11 August 2015 [p72: paras 221 and 225]; Transcript, 17 August 2015, Dr John Macintosh [p1129: lines 19-38]
- ⁸⁰ Exhibit 144, Dr John Macintosh, *Report to Grantham Floods Commission of Inquiry – Expert Hydrology Report 10 January 2011 – Circumstances and Contributing Factors*, 11 August 2015 [p72: paras 226-227]; Transcript, 17 August 2015: Dr John Macintosh [p1129: line 40 - p1130: line 18]
- ⁸¹ Exhibit 144, Dr John Macintosh, *Report to Grantham Floods Commission of Inquiry – Expert Hydrology Report 10 January 2011 – Circumstances and Contributing Factors*, 11 August 2015 [p72: para 228 - p73: para 229]; Transcript, 17 August 2015, Dr John Macintosh [p1130: line 20 - p1131: line 5]
- ⁸² Exhibit 144, Dr John Macintosh, *Report to Grantham Floods Commission of Inquiry – Expert Hydrology Report 10 January 2011 – Circumstances and Contributing Factors*, 11 August 2015 [p73: para 231]; Transcript, 17 August 2015: Dr John Macintosh [p1131: lines 7-25]
- ⁸³ Exhibit 144, Dr John Macintosh, *Report to Grantham Floods Commission of Inquiry – Expert Hydrology Report 10 January 2011 – Circumstances and Contributing Factors*, 11 August 2015 [p73: paras 230-231]; Transcript, 17 August 2015: Dr John Macintosh [p1131: lines 10-11]
- ⁸⁴ Exhibit 144, Dr John Macintosh, *Report to Grantham Floods Commission of Inquiry – Expert Hydrology Report 10 January 2011 – Circumstances and Contributing Factors*, 11 August 2015 [p70: para 216 - p71: para 218]
- ⁸⁵ Exhibit 144, Dr John Macintosh, *Report to Grantham Floods Commission of Inquiry – Expert Hydrology Report 10 January 2011 – Circumstances and Contributing Factors*, 11 August 2015 [p71: para 219].
- ⁸⁶ Exhibit 144, Dr John Macintosh, *Report to Grantham Floods Commission of Inquiry – Expert Hydrology Report 10 January 2011 – Circumstances and Contributing Factors*, 11 August 2015 [p71: para 218]; Transcript, 17 August 2015, Dr John Macintosh [p1133: line 22-29]
- ⁸⁷ Exhibit 144, Dr John Macintosh, *Report to Grantham Floods Commission of Inquiry – Expert Hydrology Report 10 January 2011 – Circumstances and Contributing Factors*, 11 August 2015 [p69: para 213].
- ⁸⁸ Exhibit 144, Dr John Macintosh, *Report to Grantham Floods Commission of Inquiry – Expert Hydrology Report 10 January 2011 – Circumstances and Contributing Factors*, 11 August 2015 [p69: para 214; p99-100: para 340]
- ⁸⁹ Transcript, 17 August 2015, Dr John Macintosh [p1133: line 11 - p1138: line 26]
- ⁹⁰ Transcript, 17 August 2015, Dr John Macintosh [p1133: lines 35-42]
- ⁹¹ Transcript, 17 August 2015, Dr John Macintosh [p1119: lines 2-9]
- ⁹² Transcript, 17 August 2015, Dr John Macintosh [p1133: lines 11-45]
- ⁹³ Transcript, 17 August 2015, Dr John Macintosh [p1134: lines 1-9]
- ⁹⁴ Exhibit 144, Dr John Macintosh, *Report to Grantham Floods Commission of Inquiry – Expert Hydrology Report 10 January 2011 – Circumstances and Contributing Factors*, 11 August 2015 [p23: para 16]; Transcript, 17 August 2015, Dr John Macintosh [p1118: lines 20-24]
- ⁹⁵ Exhibit 144, Dr John Macintosh, *Report to Grantham Floods Commission of Inquiry – Expert Hydrology Report 10 January 2011 – Circumstances and Contributing Factors*, 11 August 2015 [p23: para 16]; Transcript, 17 August 2015, Dr John Macintosh [p1118: lines 26-27]
- ⁹⁶ Exhibit 144, Dr John Macintosh, *Report to Grantham Floods Commission of Inquiry – Expert Hydrology Report 10 January 2011 – Circumstances and Contributing Factors*, 11 August 2015 [p69: para 209]
- ⁹⁷ Transcript, 17 August 2015, Dr John Macintosh [p1134: line 28 - p1135: line 45]
- ⁹⁸ Exhibit 144, Dr John Macintosh, *Report to Grantham Floods Commission of Inquiry – Expert Hydrology Report 10 January 2011 – Circumstances and Contributing Factors*, 11 August 2015 [p26: para 28]
- ⁹⁹ Transcript, 17 August 2015: Dr John Macintosh [p1135: lines 22-30]
- ¹⁰⁰ Exhibit 144, Dr John Macintosh, *Report to Grantham Floods Commission of Inquiry – Expert Hydrology Report 10 January 2011 – Circumstances and Contributing Factors*, 11 August 2015 [p26: para 28]; Transcript, 17 August 2015, Dr John Macintosh [p1134: lines 11-17]
- ¹⁰¹ Exhibit 144, Dr John Macintosh, *Report to Grantham Floods Commission of Inquiry – Expert Hydrology Report 10 January 2011 – Circumstances and Contributing Factors*, 11 August 2015 [p26-p27: para 29; p100: para 342 – p104: para 350]
- ¹⁰² Exhibit 144, Dr John Macintosh, *Report to Grantham Floods Commission of Inquiry – Expert Hydrology Report 10 January 2011 – Circumstances and Contributing Factors*, 11 August 2015 [p26: para 28]; Transcript, 17 August 2015, Dr John Macintosh [p1137: lines 13-25]
- ¹⁰³ Exhibit 144, Dr John Macintosh, *Report to Grantham Floods Commission of Inquiry – Expert Hydrology Report 10 January 2011 – Circumstances and Contributing Factors*, 11 August 2015 [p200: Table B.2]; Transcript, 17 August 2015, Dr John Macintosh [p1138: lines 13-26]
- ¹⁰⁴ Exhibit 144, Dr John Macintosh, *Report to Grantham Floods Commission of Inquiry – Expert Hydrology Report 10 January 2011 – Circumstances and Contributing Factors*, 11 August 2015 [p100: para 350]
- ¹⁰⁵ Exhibit 144, Dr John Macintosh, *Report to Grantham Floods Commission of Inquiry – Expert Hydrology Report 10 January 2011 – Circumstances and Contributing Factors*, 11 August 2015 [p104: para 350; p105 – 106: para 352]
- ¹⁰⁶ Exhibit 144, Dr John Macintosh, *Report to Grantham Floods Commission of Inquiry – Expert Hydrology Report 10 January 2011 – Circumstances and Contributing Factors*, 11 August 2015 [p106: para 354]; Transcript, 17 August 2015: Dr John Macintosh [p1137: line 45 - p1138: line 11]

- ¹⁰⁷ Transcript, 17 August 2015, Dr John Macintosh [p1132: line 43 - p1133: line 3]; Transcript, 19 August 2015, Dr John Macintosh [p1264: lines 26-27]
- ¹⁰⁸ Transcript, 17 August 2015, Dr John Macintosh [p1142: lines 24-29]
- ¹⁰⁹ Transcript, 17 August 2015, Dr John Macintosh [p1116: line 42 – p1117: line 5]
- ¹¹⁰ Exhibit 144, Dr John Macintosh, *Report to Grantham Floods Commission of Inquiry – Expert Hydrology Report 10 January 2011 – Circumstances and Contributing Factors*, 11 August 2015 [p38: para 88]
- ¹¹¹ Transcript, 17 August 2015 Dr John Macintosh [p1157: line 31-33]
- ¹¹² Exhibit 144, Dr John Macintosh, *Report to Grantham Floods Commission of Inquiry – Expert Hydrology Report 10 January 2011 – Circumstances and Contributing Factors*, 11 August 2015 [p176: para 508]
- ¹¹³ Exhibit 304, Dr John Macintosh, *Report to Grantham Floods Commission of Inquiry – Expert Hydrology Report 10 January 2011 – Circumstances and Contributing Factors Supplementary Material No. 2*, 3 September 2015 [p39: para 55 - p46: para 89]
- ¹¹⁴ Exhibit 144, Dr John Macintosh, *Report to Grantham Floods Commission of Inquiry – Expert Hydrology Report 10 January 2011 – Circumstances and Contributing Factors*, 11 August 2015 [p151: para 454 - p154: para 459; p176: para 506]
- ¹¹⁵ Exhibit 22, Statement of Frances Arndt, 29 January 2011 [p3: para 11].
- ¹¹⁶ Exhibit 23, Statement of Frances Arndt, 1 July 2015 [p2: para 5 - p3: para 8]
- ¹¹⁷ Exhibit 23, Statement of Frances Arndt, 1 July 2015 [p2: para 5 - p3: para 8]
- ¹¹⁸ Exhibit 304, Dr John Macintosh, *Report to Grantham Floods Commission of Inquiry – Expert Hydrology Report 10 January 2011 – Circumstances and Contributing Factors Supplementary Material No. 2*, 3 September 2015 [p50: para 107 - p51: para 116]
- ¹¹⁹ Exhibit 144, Dr John Macintosh, *Report to Grantham Floods Commission of Inquiry – Expert Hydrology Report 10 January 2011 – Circumstances and Contributing Factors*, 11 August 2015 [p154: paras 460-462; p176: para 506]; Transcript, 17 August 2015, Dr John Macintosh [p1152: line 39 - p1153: line 5]; Transcript, 19 August 2015: Dr John Macintosh [p1306: line 24 - p1308: line 5]
- ¹²⁰ Exhibit 152, Transcripts of 000 calls made by Mr Bruce Marshall on 10 January 2011
- ¹²¹ Exhibit 144, Dr John Macintosh, *Report to Grantham Floods Commission of Inquiry – Expert Hydrology Report 10 January 2011 – Circumstances and Contributing Factors*, 11 August 2015 [p155: para 463 - p159: para 473]; Exhibit 304, Dr John Macintosh, *Report to Grantham Floods Commission of Inquiry – Expert Hydrology Report 10 January 2011 – Circumstances and Contributing Factors Supplementary Material No. 2*, 3 September 2015 [p38: paras 50-54]; Transcript, 17 August 2015, Dr John Macintosh [p1149: line 16 - p1150: line 9; p1153: line 44 - p1154: line 41]
- ¹²² Exhibit 25, Statement of Jonathan Sippel, 1 July 2015 [p5: paras 27-28]; Transcript, 21 July 2015, Mr Jonathan Sippel [p123: lines 18 - 25; p123: line 39 - p124: line 45]
- ¹²³ Exhibit 25, Statement of Jonathan Sippel, 1 July 2015 [p10: para 55]
- ¹²⁴ Transcript, 21 July 2015, Jonathan Sippel [p138: lines 5-17]
- ¹²⁵ Exhibit 144, Dr John Macintosh, *Report to Grantham Floods Commission of Inquiry – Expert Hydrology Report 10 January 2011 – Circumstances and Contributing Factors*, 11 August 2015 [p160: para 474 - p163: para 483; p176: para 506]; Transcript, 17 August 2015, Dr John Macintosh [p1150: line 13 - p1151: line 13]
- ¹²⁶ Exhibit 29, Statement of Helen Besley, 2 July 2015 [p2: para 11 – p4: para 30]
- ¹²⁷ Exhibit 153, Transcript of 000 call placed by Helen Besley on 10 January 2011
- ¹²⁸ Exhibit 144, Dr John Macintosh, *Report to Grantham Floods Commission of Inquiry – Expert Hydrology Report 10 January 2011 – Circumstances and Contributing Factors*, 11 August 2015 [p163: para 481 - p165: para 483]
- ¹²⁹ Exhibit 144, Dr John Macintosh, *Report to Grantham Floods Commission of Inquiry – Expert Hydrology Report 10 January 2011 – Circumstances and Contributing Factors*, 11 August 2015 [p164: para 484 - p170: para 491; p176: para 506]; Transcript, 17 August 2015, Dr John Macintosh [p1154: line 43 - p1156: line 6]
- ¹³⁰ Exhibit 28, Statement of Mr Wayne Lack, 7 July 2015 [p4: paras 20-21]
- ¹³¹ Exhibit 28, Photographs taken by Mr Wayne Lack on 10 January 2011
- ¹³² Exhibit 144, Dr John Macintosh, *Report to Grantham Floods Commission of Inquiry – Expert Hydrology Report 10 January 2011 – Circumstances and Contributing Factors*, 11 August 2015 [p170: para 492 - p172: para 495; p176: para 506]; Transcript, 17 August 2015, Dr John Macintosh [p1153: lines 15-33]
- ¹³³ Exhibit 26, Statement of Lance William Richardson, 1 July 2015 [p4 – 5: para 18]
- ¹³⁴ Exhibit 26, Statement of Lance William Richardson, 1 July 2015 [Attachment LWR-2, Videos taken by Mr Lance Richardson on 10 January 2011]
- ¹³⁵ Exhibit 144, Dr John Macintosh, *Report to Grantham Floods Commission of Inquiry – Expert Hydrology Report 10 January 2011 – Circumstances and Contributing Factors*, 11 August 2015 [p172: para 496 - p176: para 505; p176: para 506]; Transcript, 17 August 2015, Dr John Macintosh [p1147: line 34 - p1149 line 10]
- ¹³⁶ Exhibit 48, Statement of Anthony McIntosh, 1 July 2015 [Attachment AM-3, Video 1 taken by Anthony McIntosh on 10 January 2011]
- ¹³⁷ Exhibit 48, USB stick containing additional photographs provided by Anthony McIntosh and taken on 10 January 2011
- ¹³⁸ Exhibit 48, USB stick containing additional photographs provided by Anthony McIntosh and taken on 10 January 2011
- ¹³⁹ Exhibit 304, Dr John Macintosh, *Report to Grantham Floods Commission of Inquiry – Expert Hydrology Report 10 January 2011 – Circumstances and Contributing Factors Supplementary Material No. 2*, 3 September 2015 [p41: para 66 - p46: para 83; p46: para 87]
- ¹⁴⁰ Exhibit 282, Statements of Harry Castle dated 29 January 2011 and 26 August 2015
- ¹⁴¹ Exhibit 304, Dr John Macintosh, *Report to Grantham Floods Commission of Inquiry – Expert Hydrology Report 10 January 2011 – Circumstances and Contributing Factors Supplementary Material No. 2*, 3 September 2015 [p39: para 56 - p41: para 65; p46: paras 86 and 88]
- ¹⁴² Exhibit 164, Statutory Declaration of Anthony McIntosh, 20 August 2015

- ¹⁴³ Exhibit 144, Dr John Macintosh, *Report to Grantham Floods Commission of Inquiry – Expert Hydrology Report 10 January 2011 – Circumstances and Contributing Factors*, 11 August 2015 [p176: para 507]; Exhibit 304, Dr John Macintosh, *Report to Grantham Floods Commission of Inquiry – Expert Hydrology Report 10 January 2011 – Circumstances and Contributing Factors Supplementary Material No. 2*, 3 September 2015 [p46: paras 87-88]
- ¹⁴⁴ Exhibit 144, Dr John Macintosh, *Report to Grantham Floods Commission of Inquiry – Expert Hydrology Report 10 January 2011 – Circumstances and Contributing Factors*, 11 August 2015 [p132: para 414]
- ¹⁴⁵ Exhibit 144, Dr John Macintosh, *Report to Grantham Floods Commission of Inquiry – Expert Hydrology Report 10 January 2011 – Circumstances and Contributing Factors*, 11 August 2015 [p132: para 415 - p136: para 420]
- ¹⁴⁶ Exhibit 144, Dr John Macintosh, *Report to Grantham Floods Commission of Inquiry – Expert Hydrology Report 10 January 2011 – Circumstances and Contributing Factors*, 11 August 2015 [p132: paras 415 and 417]; Transcript, 17 August 2015, Dr John Macintosh [p1157: lines 35-45]
- ¹⁴⁷ Exhibit 144, Dr John Macintosh, *Report to Grantham Floods Commission of Inquiry – Expert Hydrology Report 10 January 2011 – Circumstances and Contributing Factors*, 11 August 2015 [p132: para 417]; Transcript, 17 August 2015, Dr John Macintosh [p1159: lines 1-11]
- ¹⁴⁸ Exhibit 144, Dr John Macintosh, *Report to Grantham Floods Commission of Inquiry – Expert Hydrology Report 10 January 2011 – Circumstances and Contributing Factors*, 11 August 2015 [p135-p136: para 420]; Transcript, 17 August 2015: Dr John Macintosh [p1158: line 35-44]
- ¹⁴⁹ Exhibit 144, Dr John Macintosh, *Report to Grantham Floods Commission of Inquiry – Expert Hydrology Report 10 January 2011 – Circumstances and Contributing Factors*, 11 August 2015 [p135: para 419]; Transcript, 17 August 2015, Dr John Macintosh [p1158: line 27-33]
- ¹⁵⁰ Transcript, 17 August 2015, Dr John Macintosh [p1159: lines 4-11]
- ¹⁵¹ Exhibit 144, Dr John Macintosh, *Report to Grantham Floods Commission of Inquiry – Expert Hydrology Report 10 January 2011 – Circumstances and Contributing Factors*, 11 August 2015 [p132: para 418]; Transcript, 17 August 2015, Dr John Macintosh [p1159: lines 13 -20]
- ¹⁵² Transcript, 17 August 2015: Dr John Macintosh [p1159: lines 16-20]
- ¹⁵³ Transcript, 17 August 2015: Dr John Macintosh [p1157: lines 35-45]
- ¹⁵⁴ Exhibit 144, Dr John Macintosh, *Report to Grantham Floods Commission of Inquiry – Expert Hydrology Report 10 January 2011 – Circumstances and Contributing Factors*, 11 August 2015 [p41-42: para 98]; Exhibit 144, Dr John Macintosh, *Report to Grantham Floods Commission of Inquiry – Expert Hydrology Report 10 January 2011 – Circumstances and Contributing Factors*, 11 August 2015 [p21-p22: para 10]; Transcript, 17 August 2015, Dr John Macintosh [p1112: line 44-p1113: line 37]
- ¹⁵⁵ Transcript, 17 August 2015, Dr John Macintosh [p1112: line 44 - p1113: line 37]
- ¹⁵⁶ Exhibit 144, Dr John Macintosh, *Report to Grantham Floods Commission of Inquiry – Expert Hydrology Report 10 January 2011 – Circumstances and Contributing Factors*, 11 August 2015 [p80: para 269]; Exhibit 304, Dr John Macintosh, Animation of most likely scenario, 3 September 2015; Transcript, 17 August 2015, Dr John Macintosh [p1143: line 36 – p1144: line 1]
- ¹⁵⁷ Exhibit 144, Dr John Macintosh, *Report to Grantham Floods Commission of Inquiry – Expert Hydrology Report 10 January 2011 – Circumstances and Contributing Factors*, 11 August 2015 [p80: para 270; p89: Figure 9.3]
- ¹⁵⁸ Exhibit 144, Dr John Macintosh, *Report to Grantham Floods Commission of Inquiry – Expert Hydrology Report 10 January 2011 – Circumstances and Contributing Factors*, 11 August 2015 [p90: para 309]
- ¹⁵⁹ Exhibit 304, Dr John Macintosh, *Report to Grantham Floods Commission of Inquiry – Expert Hydrology Report 10 January 2011 – Circumstances and Contributing Factors Supplementary Material No. 2*, 3 September 2015 [p20: paras 15-16].
- ¹⁶⁰ Exhibit 304, Dr John Macintosh, *Report to Grantham Floods Commission of Inquiry – Expert Hydrology Report 10 January 2011 – Circumstances and Contributing Factors Supplementary Material No. 2*, 3 September 2015 [p20-21: paras 19-20]; Exhibit 303, Mr David Starr, *Supplementary report concerning pre-quarry terrain at sand batching plant*, 2 September 2015.
- ¹⁶¹ Exhibit 144, Dr John Macintosh, *Report to Grantham Floods Commission of Inquiry – Expert Hydrology Report 10 January 2011 – Circumstances and Contributing Factors Supplementary Material No. 1*, 17 August 2015 [p9: para 2]
- ¹⁶² Transcript, 17 August 2015, Dr John Macintosh [p1166: lines 29-33]
- ¹⁶³ Transcript, 17 August 2015, Dr John Macintosh [p1165: lines 1 -19]
- ¹⁶⁴ Transcript, 17 August 2015: Dr John Macintosh [p1166: lines 16-21; p1169: lines 22-23; p1171: lines 39-40]
- ¹⁶⁵ Exhibit 144, Dr John Macintosh, *Report to Grantham Floods Commission of Inquiry – Expert Hydrology Report 10 January 2011 – Circumstances and Contributing Factors*, 11 August 2015 [p106: para 358 NB. The report refers to 122.0mRL. This is a typo and should have read 122 metres AHD.]; Transcript, 17 August 2015, Dr John Macintosh [p1165: line 21 - p1166: line 27].
- ¹⁶⁶ Exhibit 144, Dr John Macintosh, *Report to Grantham Floods Commission of Inquiry – Expert Hydrology Report 10 January 2011 – Circumstances and Contributing Factors*, 11 August 2015 [p106: para 356]
- ¹⁶⁷ Exhibit 144, Dr John Macintosh, *Report to Grantham Floods Commission of Inquiry – Expert Hydrology Report 10 January 2011 – Circumstances and Contributing Factors*, 11 August 2015 [p109: Figure 10.15]
- ¹⁶⁸ Transcript, 17 August 2015: Dr John Macintosh [p1166: lines 1-27]
- ¹⁶⁹ Transcript, 17 August 2015: Dr John Macintosh [p1166: lines 16-18]
- ¹⁷⁰ Transcript, 17 August 2015: Dr John Macintosh [p1166: lines 20-21]
- ¹⁷¹ Transcript, 17 August 2015: Dr John Macintosh [p1166: lines 23-27]
- ¹⁷² Exhibit 144, Dr John Macintosh, *Report to Grantham Floods Commission of Inquiry – Expert Hydrology Report 10 January 2011 – Circumstances and Contributing Factors*, 11 August 2015 [p106: para 358; p108: paras 361-363]
- ¹⁷³ Exhibit 144, Dr John Macintosh, *Report to Grantham Floods Commission of Inquiry – Expert Hydrology Report 10 January 2011 – Circumstances and Contributing Factors*, 11 August 2015 [p108: para 364]
- ¹⁷⁴ Exhibit 144, Dr John Macintosh, *Report to Grantham Floods Commission of Inquiry – Expert Hydrology Report 10 January 2011 – Circumstances and Contributing Factors*, 11 August 2015 [p30: paras 46-47]; Transcript, 17 August 2015, Dr John Macintosh [p1166: lines 29-33]
- ¹⁷⁵ Transcript, 17 August 2015, Dr John Macintosh [p1171: line 28 - p1172: line 6]; Transcript, 20 August 2015, Mr Stefan Szykarski [p1361: line 44 - p1362: line 23]

- ²³² Exhibit 163, Mr Stefan Szykarski, *Review of Expert Hydrology Report – 10th January 2011 Flood*, 13 August 2015 [p4: para 21]; Transcript, 20 August 2015: Mr Stefan Szykarski [p1353: line 45 - p1354: line 7].
- ²³³ Transcript, 20 August 2015: Mr Stefan Szykarski [p1356: line 45 - p1357: line 11].
- ²³⁴ Transcript, 20 August 2015: Mr Stefan Szykarski [p1352: line 43 - p1353: line 3].
- ²³⁵ Exhibit 163, Mr Stefan Szykarski, *Review of Expert Hydrology Report – 10th January 2011 Flood*, 13 August 2015 [p4: para 21]; Transcript, 20 August 2015: Mr Stefan Szykarski [p1353: line 32 - p1354: line 7].
- ²³⁶ Exhibit 163, Mr Stefan Szykarski, *Review of Expert Hydrology Report – 10th January 2011 Flood*, 13 August 2015 [p5: paras 22-23]; Transcript, 20 August 2015: Mr Stefan Szykarski [p1354: line 9-22].
- ²³⁷ Exhibit 163, Mr Stefan Szykarski, *Review of Expert Hydrology Report – 10th January 2011 Flood*, 13 August 2015 [p5: para 22].
- ²³⁸ Exhibit 163, Mr Stefan Szykarski, *Review of Expert Hydrology Report – 10th January 2011 Flood*, 13 August 2015 [p5: paras 23-24].
- ²³⁹ Exhibit 163, Mr Stefan Szykarski, *Review of Expert Hydrology Report – 10th January 2011 Flood*, 13 August 2015 [p5: para 24]; Transcript, 20 August 2015: Mr Stefan Szykarski [p1354: lines 9-26].
- ²⁴⁰ Exhibit 163, Mr Stefan Szykarski, *Review of Expert Hydrology Report – 10th January 2011 Flood*, 13 August 2015 [p5: para 26].
- ²⁴¹ Transcript, 20 August 2015, Mr Stefan Szykarski [p1355: line 10-23].
- ²⁴² Transcript, 20 August 2015, Mr Stefan Szykarski [p1355: line 35-39].
- ²⁴³ Exhibit 163, Mr Stefan Szykarski, *Review of Expert Hydrology Report – 10th January 2011 Flood*, 13 August 2015 [p5: para 28]; Transcript, 20 August 2015, Mr Stefan Szykarski [p1355: line 25-27].
- ²⁴⁴ Transcript, 20 August 2015, Mr Stefan Szykarski [p1355: line 42 - p1356: line 2].
- ²⁴⁵ Transcript, 20 August 2015, Mr Stefan Szykarski [p1355: line 42 - p1356: line 2].
- ²⁴⁶ Exhibit 163, Mr Stefan Szykarski, *Review of Expert Hydrology Report – 10th January 2011 Flood*, 13 August 2015 [p6 -7: para 31]; Transcript, 20 August 2015, Mr Stefan Szykarski [p1356, line 29-36].
- ²⁴⁷ Exhibit 163, Mr Stefan Szykarski, *Review of Expert Hydrology Report – 10th January 2011 Flood*, 13 August 2015 [p7: para 32]; Transcript, 20 August 2015, Mr Stefan Szykarski [p1380: line 44 -p1381: line 17].
- ²⁴⁸ Exhibit 163, Mr Stefan Szykarski, *Review of Expert Hydrology Report – 10th January 2011 Flood*, 13 August 2015 [p6: para 33]; Transcript, 20 August 2015, Mr Stefan Szykarski [p1356: line 45 - p1357, line 11].
- ²⁴⁹ Exhibit 163, Mr Stefan Szykarski, *Review of Expert Hydrology Report – 10th January 2011 Flood*, 13 August 2015 [p6: para 33].
- ²⁵⁰ Exhibit 163, Mr Stefan Szykarski, *Review of Expert Hydrology Report – 10th January 2011 Flood*, 13 August 2015 [p6: para 33].
- ²⁵¹ Exhibit 163, Mr Stefan Szykarski, *Review of Expert Hydrology Report – 10th January 2011 Flood*, 13 August 2015 [p2: para 7(c); p10: para 54(a)]; Transcript, 20 August 2015, Mr Stefan Szykarski [p1362: lines 25-36].
- ²⁵² Exhibit 163, Mr Stefan Szykarski, *Review of Expert Hydrology Report – 10th January 2011 Flood*, 13 August 2015 [p2: para 7(c); p10: para 54(a)]; Transcript, 20 August 2015, Mr Stefan Szykarski [p1382, lines 38-40].
- ²⁵³ Transcript, 20 August 2015, Mr Stefan Szykarski [p1382, line 34-36].
- ²⁵⁴ Exhibit 163, Mr Stefan Szykarski, *Review of Expert Hydrology Report – 10th January 2011 Flood*, 13 August 2015 [p2: para 7(e), p10-11: para 55]; Transcript, 20 August 2015, Mr Stefan Szykarski [p1363: lines 12-34].
- ²⁵⁵ Exhibit 163, Mr Stefan Szykarski, *Review of Expert Hydrology Report – 10th January 2011 Flood*, 13 August 2015 [p8: para 45].
- ²⁵⁶ Exhibit 163, Mr Stefan Szykarski, *Review of Expert Hydrology Report – 10th January 2011 Flood*, 13 August 2015 [p9: para 47].
- ²⁵⁷ Transcript, 20 August 2015, Mr Szykarski [p1369: line 25-30].
- ²⁵⁸ Exhibit 163, Mr Stefan Szykarski, *Review of Expert Hydrology Report – 10th January 2011 Flood*, 13 August 2015 [p10: para 54(b) and 54(c)]; Transcript, 20 August 2015, Mr Stefan Szykarski [p1361: line 24-43].
- ²⁵⁹ Exhibit 19, Dr David Newton, *Impact of the Grantham Sand quarry on the January 2011 Flood in Grantham*, 3 July 2015 [p13: para 22].
- ²⁶⁰ Exhibit 19, Dr David Newton, *Impact of the Grantham Sand quarry on the January 2011 Flood in Grantham*, 3 July 2015 [p13: para 21].
- ²⁶¹ Exhibit 19, Dr David Newton, *Impact of the Grantham Sand quarry on the January 2011 Flood in Grantham*, 3 July 2015 [p13: para 21].
- ²⁶² Exhibit 19, Dr David Newton, *Impact of the Grantham Sand quarry on the January 2011 Flood in Grantham*, 3 July 2015.
- ²⁶³ Exhibit 166, Dr David Newton, *January 2011 flood in Grantham Supplementary Report 1*, 17 August 2015.
- ²⁶⁴ Exhibit 167, Dr David Newton, four videos prepared by Dr Newton, August 2015.
- ²⁶⁵ Exhibit 19, Dr David Newton, *Impact of the Grantham Sand quarry on the January 2011 Flood in Grantham*, 3 July 2015 [p91-100, Appendix A]; Exhibit 167, Dr David Newton, Four videos prepared by Dr Newton, August 2015 [p10: para 14].
- ²⁶⁶ Exhibit 146, Dr Phillip Jordan, *Provision of Hydrological Advice to the Queensland Floods Commission of Inquiry – Assessment of Impact of Quarrying Operations on Flash Flooding in Grantham on 10 January 2011*, 16 September 2011.
- ²⁶⁷ Exhibit 145, Stefan Szykarski, *Grantham and Wagner quarry Review of Flood Impact 10th January 2011 event prepared for Nationwide News Pty Ltd*, February 2015.
- ²⁶⁸ Exhibit 110, Coroners Court, *Inquest into the deaths caused by the South-East Queensland floods of January 2011*, Office of State Coroner, 5 June 2012.
- ²⁶⁹ Exhibit 69, channel 9, Aerial video footage of flooding in Grantham, 10 January 2011; Exhibit 120, channel 10, Aerial video footage of flooding in Grantham, 10 January 2011.
- ²⁷⁰ Exhibit 109, Lockyer Valley Regional Council, Post-flood peak flood survey data for Grantham, 10 January 2011.
- ²⁷¹ Exhibit 40, Statement of Richard Cork, 2 July 2015.
- ²⁷² Exhibit 107, OWR Surveyors, Ground level survey plan of Grantham quarry, 2008.
- ²⁷³ Exhibit 3, Sinclair Knight Merz, Lockyer Creek Flood Risk Management Study for Lockyer Valley Regional Council, December 2014.
- ²⁷⁴ Exhibit 19, Dr David Newton, *Impact of the Grantham Sand quarry on the January 2011 Flood in Grantham*, 3 July 2015 [p13: para 21].
- ²⁷⁵ Exhibit 19, Dr David Newton, *Impact of the Grantham Sand quarry on the January 2011 Flood in Grantham*, 3 July 2015 [p49: para 88].
- ²⁷⁶ Exhibit 19, Dr David Newton, *Impact of the Grantham Sand quarry on the January 2011 Flood in Grantham*, 3 July 2015 [p49: para 90].

- ²⁷⁷ Exhibit 19, Dr David Newton, *Impact of the Grantham Sand quarry on the January 2011 Flood in Grantham*, 3 July 2015 [p49: para 90].
- ²⁷⁸ Exhibit 19, Dr David Newton, *Impact of the Grantham Sand quarry on the January 2011 Flood in Grantham*, 3 July 2015 [p53: para 104].
- ²⁷⁹ Exhibit 19, Dr David Newton, *Impact of the Grantham Sand quarry on the January 2011 Flood in Grantham*, 3 July 2015 [p53: para 104].
- ²⁸⁰ Exhibit 19, Dr David Newton, *Impact of the Grantham Sand quarry on the January 2011 Flood in Grantham*, 3 July 2015 [p53: para 104].
- ²⁸¹ Exhibit 19, Dr David Newton, *Impact of the Grantham Sand quarry on the January 2011 Flood in Grantham*, 3 July 2015 [p56: para 114].
- ²⁸² Exhibit 19, Dr David Newton, *Impact of the Grantham Sand quarry on the January 2011 Flood in Grantham*, 3 July 2015 [p54: paras 106-107].
- ²⁸³ Exhibit 19, Dr David Newton, *Impact of the Grantham Sand quarry on the January 2011 Flood in Grantham*, 3 July 2015 [p54: para 107].
- ²⁸⁴ Exhibit 19, Dr David Newton, *Impact of the Grantham Sand quarry on the January 2011 Flood in Grantham*, 3 July 2015 [p55: paras 108-109]; Exhibit 166, Dr David Newton, *January 2011 flood in Grantham Supplementary Report 1*, 17 August 2015 [p26-27: paras 53 and 57].
- ²⁸⁵ Exhibit 19, Dr David Newton, *Impact of the Grantham Sand quarry on the January 2011 Flood in Grantham*, 3 July 2015 [p55: paras 109-110].
- ²⁸⁶ Exhibit 19, Dr David Newton, *Impact of the Grantham Sand quarry on the January 2011 Flood in Grantham*, 3 July 2015 [p55: para 110]; Exhibit 166, Dr David Newton, *January 2011 flood in Grantham Supplementary Report 1*, 17 August 2015 [p26-27: para 57].
- ²⁸⁷ Exhibit 19, Dr David Newton, *Impact of the Grantham Sand quarry on the January 2011 Flood in Grantham*, 3 July 2015 [p53: para 104].
- ²⁸⁸ Exhibit 19, Dr David Newton, *Impact of the Grantham Sand quarry on the January 2011 Flood in Grantham*, 3 July 2015 [p56: para 114].
- ²⁸⁹ Exhibit 19, Dr David Newton, *Impact of the Grantham Sand quarry on the January 2011 Flood in Grantham*, 3 July 2015 [p51: paras 99-100].
- ²⁹⁰ Exhibit 19, Dr David Newton, *Impact of the Grantham Sand quarry on the January 2011 Flood in Grantham*, 3 July 2015 [p51: paras 101-102].
- ²⁹¹ Exhibit 19, Dr David Newton, *Impact of the Grantham Sand quarry on the January 2011 Flood in Grantham*, 3 July 2015 [p50: paras 92-93].
- ²⁹² Exhibit 19, Dr David Newton, *Impact of the Grantham Sand quarry on the January 2011 Flood in Grantham*, 3 July 2015 [p18: para 22 - p19: para 44; p50: para 94].
- ²⁹³ Exhibit 19, Dr David Newton, *Impact of the Grantham Sand quarry on the January 2011 Flood in Grantham*, 3 July 2015 [p18: paras 38-40].
- ²⁹⁴ Exhibit 19, Dr David Newton, *Impact of the Grantham Sand quarry on the January 2011 Flood in Grantham*, 3 July 2015 [p73: para 146].
- ²⁹⁵ Exhibit 19, Dr David Newton, *Impact of the Grantham Sand quarry on the January 2011 Flood in Grantham*, 3 July 2015 [p73: para 151].
- ²⁹⁶ Exhibit 19, Dr David Newton, *Impact of the Grantham Sand quarry on the January 2011 Flood in Grantham*, 3 July 2015 [p50: para 98].
- ²⁹⁷ Exhibit 19, Dr David Newton, *Impact of the Grantham Sand quarry on the January 2011 Flood in Grantham*, 3 July 2015 [p57: para 121].
- ²⁹⁸ Exhibit 166, Dr David Newton, *January 2011 flood in Grantham Supplementary Report 1*, 17 August 2015 [p10: para 15].
- ²⁹⁹ Exhibit 166, Dr David Newton, *January 2011 flood in Grantham Supplementary Report 1*, 17 August 2015 [p10: para 15].
- ³⁰⁰ Exhibit 166, Dr David Newton, *January 2011 flood in Grantham Supplementary Report 1*, 17 August 2015 [p10: para 16].
- ³⁰¹ Exhibit 166, Dr David Newton, *January 2011 flood in Grantham Supplementary Report 1*, 17 August 2015 [p10: para 16].
- ³⁰² Exhibit 19, Dr David Newton, *Impact of the Grantham Sand quarry on the January 2011 Flood in Grantham*, 3 July 2015 [p57: para 126 - p 58: para 129]; Exhibit 166, Dr David Newton, *January 2011 flood in Grantham Supplementary Report 1*, 17 August 2015 [p12: para 21 - page 25: para 51]; Exhibit 167, Dr David Newton, Validation Animation, August 2015.
- ³⁰³ Exhibit 167, Dr David Newton, Validation Animation, August 2015; Exhibit 48, USB stick containing additional photographs provided by Anthony McIntosh and taken on 10 January 2011.
- ³⁰⁴ Exhibit 166, Dr David Newton, *January 2011 flood in Grantham Supplementary Report 1*, 17 August 2015 [p12: para 21 to p13: para 22]; Exhibit 167, Dr David Newton, Validation Animation, August 2015; Exhibit 246, Statement of Annaka Sippel, 1 July 2015.
- ³⁰⁵ Exhibit 167, Dr David Newton, Validation Animation, August 2015; Exhibit 153, Transcript of 000 call placed by Helen Besley on 10 January 2011.
- ³⁰⁶ Exhibit 167, Dr David Newton, Validation Animation, August 2015; Transcript, 21 July 2015, Statement of Jonathan Sippel [p138: line 5-17].
- ³⁰⁷ Exhibit 166, Dr David Newton, *January 2011 flood in Grantham Supplementary Report 1*, 17 August 2015 [p14: paras 23-25]; Exhibit 167, Dr David Newton, Validation Animation, August 2015; Exhibit 150, Statement of Troy Brendan Steffens, 1 July 2015.
- ³⁰⁸ Exhibit 166, Dr David Newton, *January 2011 flood in Grantham Supplementary Report 1*, 17 August 2015 [p15: para 26 - p16]; Exhibit 167, Dr David Newton, Validation Animation, August 2015; Exhibit 251, Statement of Matthew Stibbard, 2 February 2011.
- ³⁰⁹ Exhibit 167, Dr David Newton, Validation Animation, August 2015; Exhibit 236, Statement of Luke Alexander Owen, 9 February 2011.
- ³¹⁰ Exhibit 19, Dr David Newton, *Impact of the Grantham Sand quarry on the January 2011 Flood in Grantham*, 3 July 2015 [p58: paras 128-129]; Exhibit 167, Dr David Newton, Validation Animation, August 2015; Exhibit 24, Statement of Ian William Pinkerton, 1 July 2015.
- ³¹¹ Exhibit 166, Dr David Newton, *January 2011 flood in Grantham Supplementary Report 1*, 17 August 2015 [p16: para 29 - p19: Figure 3.10]; Exhibit 28, Statement of Mr Wayne Lack, 7 July 2015.
- ³¹² Exhibit 166, Dr David Newton, *January 2011 flood in Grantham Supplementary Report 1*, 17 August 2015 [p19: para 38 - p21: Figure 3.13]; Exhibit 26, Statement of Lance William Richardson, 1 July 2015.
- ³¹³ Exhibit 166, Dr David Newton, *January 2011 flood in Grantham Supplementary Report 1*, 17 August 2015 [p21: para 41 - p22: Figure 3.14]; Exhibit 167, Dr David Newton, Validation Animation, August 2015; Exhibit 12, Extracts of videos taken by Katherine Godley, 10 January 2011.
- ³¹⁴ Exhibit 167, Dr David Newton, Validation Animation, August 2015; Exhibit 42, Audio of 000 phone calls made by Mr Daniel McGuire on 10 January 2011.
- ³¹⁵ Exhibit 166, Dr David Newton, *January 2011 flood in Grantham Supplementary Report 1*, 17 August 2015 [p23: para 51]; Exhibit 38, Photographs taken by Mr Martin Warburton, 10 January 2011; Exhibit 43, Videos taken by Mr Martin Warburton, 10 January 2011.
- ³¹⁶ Exhibit 166, Dr David Newton, *January 2011 flood in Grantham Supplementary Report 1*, 17 August 2015 [p23: para 51]; Transcript, 24 July 2015, Mr Martin Warburton [p404: line 32-36].
- ³¹⁷ Exhibit 166, Dr David Newton, *January 2011 flood in Grantham Supplementary Report 1*, 17 August 2015 [p10: para 18; p27: para 62].
- ³¹⁸ Exhibit 167, Dr David Newton, Validation animation file prepared by Dr Newton, August 2015.
- ³¹⁹ Exhibit 109, Lockyer Valley Regional Council, Post-flood peak flood survey data for Grantham, 10 January 2011; Exhibit 40, Statement of Richard Cork, 2 July 2015.

- ³²⁰ Exhibit 19, Dr David Newton, *Impact of the Grantham Sand quarry on the January 2011 Flood in Grantham*, 3 July 2015 [p46: paras 81-83; p57: paras 124-125].
- ³²¹ Exhibit 166, Dr David Newton, *January 2011 flood in Grantham Supplementary Report 1*, 17 August 2015 [p10: para 20 to p12: Table 3.1].
- ³²² Exhibit 166, Dr David Newton, *January 2011 flood in Grantham Supplementary Report 1*, 17 August 2015 [p10: para 20 to p12: Table 3.1].
- ³²³ Exhibit 166, Dr David Newton, *January 2011 flood in Grantham Supplementary Report 1*, 17 August 2015 [p10: para 20 to p12: Table 3.1].
- ³²⁴ Exhibit 19, Dr David Newton, *Impact of the Grantham Sand quarry on the January 2011 Flood in Grantham*, 3 July 2015 [p65: para 131]; Exhibit 166, Dr David Newton, *January 2011 flood in Grantham Supplementary Report 1*, 17 August 2015 [p29: para 63].
- ³²⁵ Exhibit 166, Dr David Newton, *January 2011 flood in Grantham Supplementary Report 1*, 17 August 2015 [p29: paras 64-65].
- ³²⁶ Exhibit 166, Dr David Newton, *January 2011 flood in Grantham Supplementary Report 1*, 17 August 2015 [p29: para 64].
- ³²⁷ Exhibit 166, Dr David Newton, *January 2011 flood in Grantham Supplementary Report 1*, 17 August 2015 [p29: para 65].
- ³²⁸ Exhibit 166, Dr David Newton, *January 2011 flood in Grantham Supplementary Report 1*, 17 August 2015 [p30: Table 5.1].
- ³²⁹ Exhibit 166, Dr David Newton, *January 2011 flood in Grantham Supplementary Report 1*, 17 August 2015 [p29: para 67].
- ³³⁰ Exhibit 167, Dr David Newton), Velocity animation file, August 2015.
- ³³¹ Exhibit 19, Dr David Newton, *Impact of the Grantham Sand quarry on the January 2011 Flood in Grantham*, 3 July 2015 [p74: para 151].
- ³³² Exhibit 19, Dr David Newton, *Impact of the Grantham Sand quarry on the January 2011 Flood in Grantham*, 3 July 2015 [p31: para 48].
- ³³³ Exhibit 19, Dr David Newton, *Impact of the Grantham Sand quarry on the January 2011 Flood in Grantham*, 3 July 2015 [p31: para 50].
- ³³⁴ Exhibit 19, Dr David Newton, *Impact of the Grantham Sand quarry on the January 2011 Flood in Grantham*, 3 July 2015 [p31: para 51; p74-75: para 151].
- ³³⁵ Exhibit 19, Dr David Newton, *Impact of the Grantham Sand quarry on the January 2011 Flood in Grantham*, 3 July 2015 [p75: para 152].
- ³³⁶ Exhibit 19, Dr David Newton, *Impact of the Grantham Sand quarry on the January 2011 Flood in Grantham*, 3 July 2015 [p75: para 153].
- ³³⁷ Exhibit 19, Dr David Newton), *Impact of the Grantham Sand quarry on the January 2011 Flood in Grantham*, 3 July 2015 [p75: para 154 - p76: para 156].
- ³³⁸ Exhibit 19, Dr David Newton), *Impact of the Grantham Sand quarry on the January 2011 Flood in Grantham*, 3 July 2015 [p76-p77: para 159].
- ³³⁹ Exhibit 19, Dr David Newton, *Impact of the Grantham Sand quarry on the January 2011 Flood in Grantham*, 3 July 2015 [p79: Table 10.2].
- ³⁴⁰ Exhibit 166, Dr David Newton, *January 2011 flood in Grantham Supplementary Report 1*, 17 August 2015 [p40: Figure 6.1].
- ³⁴¹ Exhibit 19, Dr David Newton, *Impact of the Grantham Sand quarry on the January 2011 Flood in Grantham*, 3 July 2015 [p77: para 162; p79: Table 10.2].
- ³⁴² Exhibit 19, Dr David Newton, *Impact of the Grantham Sand quarry on the January 2011 Flood in Grantham*, 3 July 2015 [p77: para 167-p78: para 171].
- ³⁴³ Exhibit 19, Dr David Newton, *Impact of the Grantham Sand quarry on the January 2011 Flood in Grantham*, 3 July 2015 [p4: para 10].
- ³⁴⁴ Exhibit 19, Dr David Newton, *Impact of the Grantham Sand quarry on the January 2011 Flood in Grantham*, 3 July 2015 [p4: para 10]; Exhibit 166, Dr David Newton, *January 2011 flood in Grantham Supplementary Report 1*, 17 August 2015 [p39: para 70].
- ³⁴⁵ Exhibit 19, Dr David Newton, *Impact of the Grantham Sand quarry on the January 2011 Flood in Grantham*, 3 July 2015 [p89: para 185].
- ³⁴⁶ Exhibit 19, Dr David Newton, *Impact of the Grantham Sand quarry on the January 2011 Flood in Grantham*, 3 July 2015 [p89: para 186].
- ³⁴⁷ Exhibit 19, Dr David Newton, *Impact of the Grantham Sand quarry on the January 2011 Flood in Grantham*, 3 July 2015 [p89: paras 182-184].
- ³⁴⁸ Exhibit 19, Dr David Newton, *Impact of the Grantham Sand quarry on the January 2011 Flood in Grantham*, 3 July 2015 [p89: paras 182- 183].
- ³⁴⁹ Closing Submissions made on behalf of Grantham Families, 2 September 2015 [p16- 17: para 92].
- ³⁵⁰ Transcript, 19 August 2015: Dr John Macintosh [p1263: line 5- 15].
- ³⁵¹ Transcript, 19 August 2015: Dr John Macintosh [p1263: line 5- 15].
- ³⁵² Transcript, 19 August 2015: Dr John Macintosh [p1263: line 17- 39].
- ³⁵³ Transcript, 20 August 2015: Mr Stefan Szykarski [p1383: line 44- p1384: line 4].
- ³⁵⁴ Closing Submissions made on behalf of West Grantham Residents, 2 September 2015 [p7: para 39- 40]; Closing Submissions made on behalf of Grantham Families, 2 September 2015 [p16- 17: para 92].
- ³⁵⁵ Exhibit 131, David Starr, *Grantham quarry – Geotechnical Investigations and Expert Opinion on Formation of Earthworks for Grantham Floods Commission of Inquiry*, 28 July 2015 [p27: para 114]; Transcript, 6 August 2015, Mr David Starr [p1004: line 10- 40]; Exhibit 303, David Starr, *Grantham Quarry – Geotechnical Investigations and Expert Opinion on Formation of Earthworks – Supplementary report concerning pre-quarry terrain at sand batching plant*, 2 September 2015 [p5: para 29- p6: para 30].
- ³⁵⁶ Closing Submissions made on behalf of West Grantham Residents, 2 September 2015 [p12: para 62]; Closing Submissions made on behalf of Grantham Families, 2 September 2015 [p16- 17: paras 92- 94].
- ³⁵⁷ Exhibit 144, Dr John Macintosh, *Report to Grantham Floods Commission of Inquiry – Expert Hydrology Report 10 January 2011 – Circumstances and Contributing Factors*, 11 August 2015 [p56: para 157].
- ³⁵⁸ Transcript, 20 August 2015: Mr Stefan Szykarski [p1355: line 42- p1356: line 2].
- ³⁵⁹ Transcript, 20 August 2015: Mr Stefan Szykarski [p1355: line 42- p1356: line 2].
- ³⁶⁰ Closing Submissions made on behalf of Grantham Families, 2 September 2015 [p16- 17: para 92].
- ³⁶¹ Transcript, 19 August 2015: Dr John Macintosh [p1291: line 45- p1293: line 22].
- ³⁶² Transcript, 19 August 2015: Dr John Macintosh [p1292: line 35- 43].
- ³⁶³ Transcript, 14 September 2015: Closing Submissions [p1439: line 41- p1440 line 5].
- ³⁶⁴ Exhibit 144.07, Dr John Macintosh, *Report to Grantham Floods Commission of Inquiry – Expert Hydrology Report 10 January 2011 – Circumstances and Contributing Factors Supplementary Material*, 17 August 2015 [p9: para 2]; Exhibit 304, Dr John Macintosh, *Report to Grantham Floods Commission of Inquiry – Expert Hydrology Report 10 January 2011 – Circumstances and Contributing Factors Supplementary Material No. 2*, 3 September 2015 [p20: paras 15 to 27].

- ³⁶⁵ Exhibit 144.07, Dr John Macintosh, Report to Grantham Floods Commission of Inquiry – Expert Hydrology Report 10 January 2011 – Circumstances and Contributing Factors Supplementary Material, 17 August 2015 [p28 -33: Figures 1.29 to 1.39]; Exhibit 304, Dr John Macintosh, Report to Grantham Floods Commission of Inquiry – Expert Hydrology Report 10 January 2011 – Circumstances and Contributing Factors Supplementary Material No. 2, 3 September 2015 [p22: Figure 3.3; p23: Figure 3.4; p25: Figure 3.5 - p28: Figure 3.11].
- ³⁶⁶ Closing Submissions made on behalf of West Grantham Residents, 2 September 2015 [p9: para 50 - p12: para 58]. This submission was also made by an unrepresented party – Submission of Robert French, 15 August 2015.
- ³⁶⁷ Transcript, 19 August 2015: Dr John Macintosh [p1283: line 8 -11].
- ³⁶⁸ Transcript, 19 August 2015: Dr John Macintosh [p1283: line 13- 14]; Transcript, 20 August 2015: Mr Stefan Szykarski [p1358: line 14- 42].
- ³⁶⁹ Transcript, 19 August 2015: Dr John Macintosh [p1283: line 22- 26]; Transcript, 20 August 2015: Mr Stefan Szykarski [p1358: line 23- 31].
- ³⁷⁰ Transcript, 20 August 2015: Mr Stefan Szykarski [p1358: line 38- 42].
- ³⁷¹ Closing Submissions made on behalf of West Grantham Residents, 2 September 2015 [p10: para 54 -56].
- ³⁷² Closing Submissions made on behalf of West Grantham Residents, 2 September 2015 [p11: para 57].
- ³⁷³ Transcript, 19 August 2015: Dr John Macintosh [p1284: line 23- 28].
- ³⁷⁴ Transcript, 20 August 2015: Mr Stefan Szykarski [p1358: line 44- p1359: line 22].
- ³⁷⁵ Transcript, 20 August 2015: Mr Stefan Szykarski [p1359: line 24- 39].
- ³⁷⁶ Exhibit 304, Dr John Macintosh, *Report to Grantham Floods Commission of Inquiry – Expert Hydrology Report 10 January 2011 – Circumstances and Contributing Factors Supplementary Material No. 2*, 3 September 2015 [p37: para 48].
- ³⁷⁷ Exhibit 145, Mr Stefan Szykarski, *Grantham and Wagner quarry Review of Flood Impact 10th January 2011 event prepared for Nationwide News Pty Ltd*, February 2015. [p8: Section 4].
- ³⁷⁸ Closing Submissions made on behalf of West Grantham Residents, 2 September 2015 [p12: para 59- 60].
- ³⁷⁹ Exhibit 163, Mr Stefan Szykarski, *Review of Expert Hydrology Report – 10th January 2011 Flood, 13 August 2015* [p4: para 21]; Transcript, 20 August 2015: Mr Stefan Szykarski [p1353: line 45- p1354: line 7].
- ³⁸⁰ Transcript, 14 September 2015, Closing Submissions [p1444: line 35 - p1445: line 43].
- ³⁸¹ Exhibit 144, Dr John Macintosh, *Report to Grantham Floods Commission of Inquiry – Expert Hydrology Report 10 January 2011 – Circumstances and Contributing Factors*, 11 August 2015 [p75: para 248].
- ³⁸² Exhibit 144, Dr John Macintosh, *Report to Grantham Floods Commission of Inquiry – Expert Hydrology Report 10 January 2011 – Circumstances and Contributing Factors*, 11 August 2015 [p75: para 249].
- ³⁸³ Transcript, 14 September 2015, Closing Submissions [p1445: lines 33 -43].
- ³⁸⁴ Closing Submissions made on behalf of West Grantham Residents, 2 September 2015 [p13: paras 67- 70]; Closing Submissions made on behalf of Grantham Families, 2 September 2015 [p17: para 99- 100].
- ³⁸⁵ Transcript, 17 August 2015: Dr John Macintosh [p1132: line 43- p1133: line 3]; Transcript, 19 August 2015: Dr John Macintosh [p1264: line 26- 27].
- ³⁸⁶ Submission of Mr John Gallagher, 11 September 2015; Submission of Ms Amanda Gearing, 3 July 2015 and 24 August 2015
- ³⁸⁷ Exhibit 304, Dr John Macintosh, Report to Grantham Floods Commission of Inquiry – Expert Hydrology Report 10 January 2011 – Circumstances and Contributing Factors Supplementary Material No. 2, 3 September 2015 [p54: para 125-126].
- ³⁸⁸ Submissions of Dr Jim Galletly made on 26 June 2015, 5 August 2015, 12 August 2015, 20 August 2015, 13 September 2015 and 17 September 2015; Submission of Mr John Gillespie, 15 September 2015; Exhibit 304, Dr John Macintosh, *Report to Grantham Floods Commission of Inquiry – Expert Hydrology Report 10 January 2011 – Circumstances and Contributing Factors Supplementary Material No. 2*, 3 September 2015 [p48: para 100].
- ³⁸⁹ Submissions of Dr Jim Galletly made on 26 June 2015, 5 August 2015, 12 August 2015; Exhibit 304, Dr John Macintosh, *Report to Grantham Floods Commission of Inquiry – Expert Hydrology Report 10 January 2011 – Circumstances and Contributing Factors Supplementary Material No. 2*, 3 September 2015 [p48: para 95 - p49: para 106].
- ³⁹⁰ Submissions of Dr Jim Galletly, 13 September 2015 and 17 September 2015.
- ³⁹¹ Submission of Dr Jim Galletly, 20 August 2015; Exhibit 304, Dr John Macintosh, *Report to Grantham Floods Commission of Inquiry – Expert Hydrology Report 10 January 2011 – Circumstances and Contributing Factors Supplementary Material No. 2*, 3 September 2015 [p48: para 95 - p49: para 106].
- ³⁹² Submission of Dr Jim Galletly, 20 August 2015; Exhibit 304, Dr John Macintosh, *Report to Grantham Floods Commission of Inquiry – Expert Hydrology Report 10 January 2011 – Circumstances and Contributing Factors Supplementary Material No. 2*, 3 September 2015 [p48: para 95- p49: para 106].
- ³⁹³ Submission of Ms Amanda Gearing, 24 August 2015; Exhibit 304, Dr John Macintosh, *Report to Grantham Floods Commission of Inquiry – Expert Hydrology Report 10 January 2011 – Circumstances and Contributing Factors Supplementary Material No. 2*, 3 September 2015 [p54: para 123].
- ³⁹⁴ Submission of Mr Robert Bowyer, 7 September 2015.
- ³⁹⁵ Submission of Mr Robert Bowyer, 1 September 2015.
- ³⁹⁶ Submission of Mr Robert Bowyer, 1 September 2015.
- ³⁹⁷ Submissions of Mr Kenneth Pearce, 15 July 2015 and 23 September 2015.
- ³⁹⁸ Submission of Ms Amanda Gearing, 24 August 2015; Exhibit 304, Dr John Macintosh, *Report to Grantham Floods Commission of Inquiry – Expert Hydrology Report 10 January 2011 – Circumstances and Contributing Factors Supplementary Material No. 2*, 3 September 2015 [p54: para 128 - p55: para 131].
- ³⁹⁹ Submission of Ms Amanda Gearing, 24 August 2015; Exhibit 304, Dr John Macintosh, Report to Grantham Floods Commission of Inquiry – Expert Hydrology Report 10 January 2011 – Circumstances and Contributing Factors Supplementary Material No. 2, 3 September 2015 [p54: para 128 - p55: para 131].

⁴⁰⁰ Submission of Mr John Gallagher, 11 September 2015; Submission of Mr John Gillespie, 2 July 2015; Statutory Declaration of Mr John Gillespie of 31 August 2015; Exhibit 304, Dr John Macintosh, *Report to Grantham Floods Commission of Inquiry – Expert Hydrology Report 10 January 2011 – Circumstances and Contributing Factors Supplementary Material No. 2*, 3 September 2015 [p52: paras 117- 120].

⁴⁰¹ Submission of Mr John Gillespie, 28 September 2015.

⁴⁰² Submission of Mr John Gillespie, 2 July 2015; Submission of Mr John Gallagher, 11 September 2015.

Appendix D: Expert advice Hazard of flood waters

1. To support the interpretation of Dr Macintosh's modelling of the 10 January 2011 flood, the Commission engaged a flood hazard expert, Mr Grantley Smith.

Mr Smith's qualifications and experience

2. Mr Smith is a Chartered Professional Engineer and is presently employed as the Principal Engineer and Manager of the Water Research Laboratory at the University of New South Wales. He has extensive experience in the fields of flood hydrology, flood flow hydraulics and floodplain management gained over 24 years working with industry and government, in Australia and overseas. He also has specialist skills and knowledge of the physical processes of flood flows, modelling of flood flows, and the assessment of the vulnerability of communities, community assets and infrastructure during floods.¹

Scope of work performed by Mr Smith

3. Mr Smith was engaged to provide an opinion in relation to:²
 - a) the likely effect of fast flowing water on a town environment like Grantham i.e. a rural town with a range of buildings of different structures (brick, wood and prefabricated), all one or two stories in height and where buildings are generally well spread out; and
 - b) the effect of moving water, both with and without debris, on the type of buildings common in the Grantham area, and on people and vehicles, where the water is flowing at:
 - (i) velocities between 20 km/h to 80 km/h and
 - (ii) depths between 0.5 m to 3 m.
4. Mr Smith provided an expert report to the Commission entitled *Stability of People, Vehicles and Buildings in Flood Water* in August 2015.³ In addition, Mr Smith gave evidence concerning his report during the hearing on 17 August 2015.⁴

Velocity of floodwaters

5. Mr Smith provided advice that the most extreme natural flows occur in steep, rock lined river channels or at large flow structures such as dam spillways. In these extreme cases under large flow rates, flow speeds might peak at 75 km/hr (as was calculated for the flows at the base of Wivenhoe Dam at the height of the January 2011 flood with all spillway gates open). In the Colorado River rapids, flows have been reported by estimation as up to 55 km/hr although only measured at 22 km/hr.⁵
6. Flood waters on an alluvial floodplain would, however, rarely reach speeds greater than 20 km/h (5.5 m/s)⁶. In his opinion, flows on an alluvial flood plain might, in situations where extreme erosion of vegetation and topsoil has occurred, reach flow speeds up to 14 to 18 km/hr (4 to 5 m/s).⁷
7. In controlled tests, it has been shown that flows of 16 km/hr (4.4 m/s) can erode rocks 0.2 m in diameter. In Mr Smith's view, the amount of erosion that occurred on farmland in the Lockyer Valley in January 2011 would be consistent with flows in the order of 7 to 11 km/hr (2 to 3 m/s),⁸ and the scour in the creek channel indicated flows of

14 to 18 km/hr (4 to 5 m/s).⁹ Photographs of scour in Lockyer Creek taken near Murphys Creek, where speeds would be higher as the gradient is steeper, indicated speeds of 18 to 21.6 km/hr (5 to 6 m/s) in the channel, less on the overbank areas.¹⁰

The hazardous nature of floodwaters

8. In Mr Smith's opinion, the hazard created by flowing water largely depends on the depth and the speed with which the waters are moving, although the rate of rise of floodwaters, the amount and type of debris and sediment carried by the flows, and the warning time available prior to the flood occurring also contributes to the level of danger and the potential for damage.¹¹
9. The Flood Hazard Vulnerability Curves were developed by the National Flood Risk Action Group and are extracted from the Best Practice Floodplain Manual prepared by the Australian Emergency Management Institute (Figure D1).¹² Those curves are classified from H1 to H6 and show that flowing water becomes hazardous at relatively low depths and speeds.

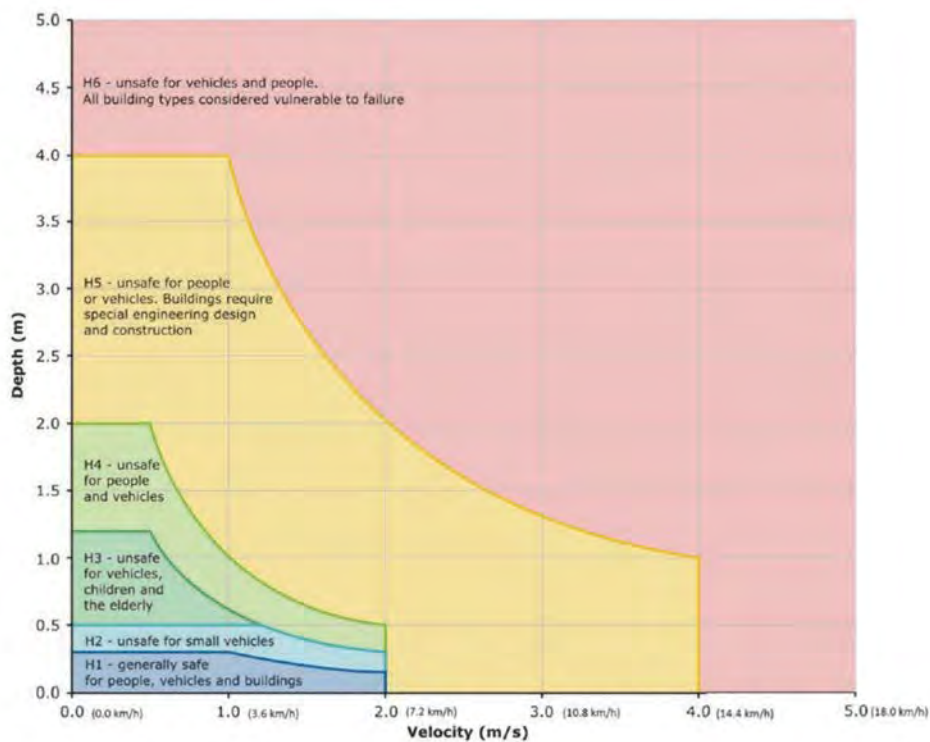

Figure D1: Flood Hazard Vulnerability Curves (AEM, 2014). Source: AEM (2014) *Australian Emergency Management Handbook: Managing the Floodplain: best practice in flood risk management in Australia* (AEM Handbook 7) available at: <https://ema.infoservices.com.au/items/HB7-2ND>

10. Mr Smith explained that small cars can become buoyant and be washed off roads in flows as shallow as 0.3m, and large four wheel drive vehicles can become unstable when flow depths are above 1.2m. Primary school age children and the elderly can become unstable and lose their footing in flows as shallow as 0.5 m and fit adults walking through floodwaters can become unstable when flow depths exceed 1.2 m.
11. Residential buildings are at risk of failure once flood flows are greater than 1.0m deep in combination with flow speeds greater than 3.6 km/hr (1 m/s). All types of buildings, including industrial buildings made of reinforced

concrete, are prone to failure once flood flows are greater than two metres deep in combination with flow speeds greater than 7.2 km/hr (2 m/s).¹³ By way of illustration, a building in a flood plain flow 2 metres deep and 20 metres wide travelling at 3.6 km/hr (1 m/s) would be exposed to a similar force as being hit by a 40 tonne semi-trailer every 15 seconds.¹⁴

12. Mr Smith explained that buildings can fail in flood waters in a number of different ways. If there is a high depth of water outside and a lower depth of water within the building, the differential imparts a force on the walls that can cause more lightly structured buildings (such as ones constructed of fibro, cladding, or light timber) to collapse. Even if the doors are opened so that the depth of water inside and outside are the same, the greater turbulence and undulation of the water outside can create dynamic forces that flex the walls in a way they are not designed to cope with, causing failure.¹⁵
13. At lower depths, different mechanisms may cause failure. Even at 1m deep and a low flow speed of 1.5 m/s, water accelerating to get around the corners of a building may, depending on the ground conditions, erode the foundations. Once the foundations start eroding then the building can become unstable and the walls collapse. At velocities of 1.5 to 2 m/s, suction forces created at the back of the building are able to pull bricks out of the wall. At faster velocities, if the flow gets underneath a building it creates an uplift force on it. Wooden buildings can sometimes become buoyant unless they are designed to withstand flood forces,¹⁶ and if buildings and structures are close together, then the velocity of flood waters passing between buildings can increase, producing a higher level of hazard.¹⁷

Mr Smith's opinion as to the effect of the 10 January 2011 flood on people, vehicles and buildings

14. Mr Smith prepared his report for the Commission independently, without having seen the work of the Commission's expert hydraulic engineer, and without the Commission providing details of witness statements.
15. At the hearing, however, he was asked to consider the observations of the following witnesses:
 - c) Mr Martin Warburton, who recalled that the flood removed a concrete skate park estimated to be approximately 70 square metres in size;¹⁸
 - d) Mr Francis King, who described his experiences during the flooding and described being lifted horizontally by the floodwaters while he held onto a tree so that he was "*straight like a pole*";¹⁹
 - e) Mrs Frances Arndt, who described the effect of floodwaters on her and her husband's (Mr Kenley Arndt) vehicle while she and her husband attempted to drive the vehicle along Gatton-Helidon Road;²⁰
 - f) Mr Lance Richardson, who took video footage during the floods that showed floodwaters forcing out bricks from the Grantham Hotel.²¹
16. Mr Smith's opinion was that a concrete structure such as a skate ramp 1.5 m high could be damaged if overtopped by flows moving between 1 to 2 m/s. This would create enough force to lift the structure and break it apart. In addition, the foundations could be eroded, creating a hole into which the structure could drop and break.²²
17. A person clinging to a pole could be lifted horizontally by water flowing in the order of 2 to 3 m/s. Mr Smith's opinion was that it would become very difficult to cling on to the pole for any length of time in water faster than this.²³

18. A four wheel drive such as Mr and Mrs Arndt's vehicle would, in Mr Smith's opinion, just start to become unstable in water 1m deep flowing at 1 m/s. As the water grew deeper, the vehicle would then become completely unstable and be swept away.²⁴
19. It was likely that the bricks were forced out of the walls of the Grantham hotel when water got under the floor of the building and then accelerated as it escaped through openings. This would have increased the force of the water at these points sufficiently to pull the bricks out of the wall.²⁵

Reliability of Mr Smith's opinion

20. I consider Mr Smith's opinion to be sound and reliable. The Commission has not received any submissions to the contrary.

Use of Mr Smith's opinion to understand other flooding effects

21. Mr Smith's opinion can be used to assist in understanding the effect of floodwaters on other structures in Grantham. In this respect, the Commission has been provided with a photograph of the railway line taken in the vicinity of the Grantham railway bridge showing substantial erosion of the blue aggregate and twisting of the railway lines themselves (Figure D2). Prior to the flood, the railway was elevated above ground level by an embankment about two metres high.
22. As discussed in Appendix C of this report, the Commission engaged an expert hydraulic engineer, Dr John Macintosh, to conduct investigations on the likely factors that may have contributed to the flooding in Grantham. Dr Macintosh considered the likely maximum average depth, average velocity and average intensity (depth multiplied by velocity) of floodwaters across the length of the railway embankment.²⁶ In Dr Macintosh's opinion, the maximum average depth was 2.6 metres, the maximum average velocity was 1.2 m/s, and the maximum average intensity was $2.8\text{m}^2/\text{s}$.²⁷
23. Inspection of Figure D1 above shows that in these conditions, the floodwaters had reached the H5 flood hazard level – meaning that buildings were vulnerable to damage unless specially engineered to withstand flooding, and even concrete reinforced structures were becoming close to their limit of stability.
24. In my view, this assessment is consistent with the damage that was observed to the railway line on 10 January 2011.



Figure D2: Grantham railway.

Source: Submission of Ian Garrard, 14 July 2015.

¹ Exhibit 142, Grantley Smith, *Expert opinion: Stability of People, Vehicles and Buildings in Flood Water, 2015* [section 1.1 and Appendix B]; Transcript 17 August 2015: Grantley Smith [p1079 line-9]

² Exhibit 142, Grantley Smith, *Expert opinion: Stability of People, Vehicles and Buildings in Flood Water, 2015* [p1, Section 1]; Transcript 17 August 2015: Mr Grantley Smith [p1079, line 21 - 27]

³ Exhibit 142, Grantley Smith, *Expert opinion: Stability of People, Vehicles and Buildings in Flood Water, 2015*

⁴ Transcript 17 August 2015: Grantley Smith [p1078 - 1109]

⁵ Exhibit 142, Grantley Smith, *Expert opinion: Stability of People, Vehicles and Buildings in Flood Water, 2015* [sections 3.1, 3.2]

⁶ Exhibit 142, Grantley Smith, *Expert opinion: Stability of People, Vehicles and Buildings in Flood Water, 2015* [section 3.3: para 5]

⁷ Exhibit 142, Grantley Smith, *Expert opinion: Stability of People, Vehicles and Buildings in Flood Water, 2015* [section 3.4: para 1 -2]

⁸ Exhibit 142, Grantley Smith, *Expert opinion: Stability of People, Vehicles and Buildings in Flood Water, 2015* section 3.3: 4th paragraph; Transcript 17 August 2015: Grantley Smith [p1081 line 21-31]

⁹ Transcript 17 August 2015: Grantley Smith [p1081 L133-36]

¹⁰ Transcript 17 August 2015: Grantley Smith [P 1094 L29 - p1095 L9]

¹¹ Exhibit 142, Grantley Smith, *Expert opinion: Stability of People, Vehicles and Buildings in Flood Water, 2015* [section 4, para 2 - 3]

¹² Exhibit 142, Grantley Smith, *Expert opinion: Stability of People, Vehicles and Buildings in Flood Water, 2015* [section 4, para 1]

¹³ Exhibit 142, Grantley Smith, *Expert opinion: Stability of People, Vehicles and Buildings in Flood Water, 2015* [section 6 para 1].

¹⁴ Exhibit 142, Grantley Smith, *Expert opinion: Stability of People, Vehicles and Buildings in Flood Water, 2015* [section 5, Section 6]; Transcript 17 August 2015: Grantley Smith [p 1086 line 31 – p1087 line 1]

¹⁵ Transcript 17 August 2015: Grantley Smith [P1085 line 26 – 34; p1089 line 30 – 43]

¹⁶ Transcript 17 August 2015: Grantley Smith [P1085 line35 – p1086 line 9]

¹⁷ Transcript 17 August 2015: Grantley Smith [P1108 line 44 – 1109 line 1]

¹⁸ Transcript 25 July 2015: Mr Martin Warburton [P391, lines 30 - 40]

¹⁹ Exhibit 27, Statement of Frances King, 21 January 2011 [p3, para 11; p4, para 20 – 21]; Transcript 22 July 2015: Mr Frances King, [p188, lines 38 - 41].

²⁰ Transcript 21 July 2015: Mrs Frances Arndt [p91, line 45 - p95, line 10]; Exhibit 23, Statement of Frances Arndt, 1 July 2015 [p2 - 3, para 5 - 8].

-
- ²¹ Exhibit 26, Statement of Lance William Richardson, 1 July 2015 [Attachment LWR-2, Videos taken by Lance Richardson on 10 January 2011]; Transcript 21 July 2015: Mr Lance Richardson, [p171, lines 16 - 21].
- ²² Transcript 17 August 2015: Grantley Smith [P1087 lines 5 - 26]
- ²³ Transcript 17 August 2015: Grantley Smith [P1087 lines 27 - 40]
- ²⁴ Transcript 17 August 2015: Grantley Smith [P1088 lines 1 - 27]
- ²⁵ Transcript 17 August 2015: Grantley Smith [P1090 lines 3 - 20]
- ²⁶ Exhibit 304, Dr John Macintosh, *Report to the Grantham Floods Commission of Inquiry – Expert Hydrology Report 10 January 2011 – Circumstances and Contributing Factors Supplementary Material No 2, 3 September 2015*, [p29, para 32].
- ²⁷ Exhibit 304, Dr John Macintosh, *Report to the Grantham Floods Commission of Inquiry – Expert Hydrology Report 10 January 2011 – Circumstances and Contributing Factors Supplementary Material No 2, 3 September 2015*, [p36, Table 4.1].

Appendix E: Matters outside the terms of reference

1. During the course of the Commission, residents, concerned individuals and other parties raised a number of matters outside the Commission's Terms of Reference. However, information addressing some of those matters was provided to me as part of my investigations and is included below for completeness.

The allegation the State refused offers of assistance from the Australian Defence Force to deploy Blackhawk helicopters to rescue Grantham residents

2. One of the concerns raised by Lockyer Valley Regional Council Mayor, Mr Jones, was that he had been told¹, by an unnamed army officer, that the Oakey Army Aviation Base offered to provide Blackhawk helicopters to assist in the evacuation of Grantham on the afternoon of 10 January 2011, but this offer was refused by the State. The information provided to Mr Jones was, as Mr Jones accepted, incorrect.²
3. When a disaster is of such immensity that it cannot be managed at the local, district and State government levels, the State government can request assistance of the Australian Defence Force from the Commonwealth Government through Emergency Management Australia, a division in the Department of the Commonwealth Attorney-General.³ The protocol is that the State Disaster Coordination Centre requests assistance from the Australian Defence Force, which then determines whether it can assist and if so, how.⁴ An Australian Defence Force liaison officer is a permanent member of the State Disaster Coordination Centre to facilitate such liaison.
4. At 4 pm on 10 January 2011, the Toowoomba District Disaster Management Group made a telephone request to the State Disaster Coordination Centre for Australian Defence Force helicopter support requesting Australian Defence Force Blackhawk assistance for the Toowoomba and Lockyer Valley area. This was confirmed in a follow up email to the District Disaster Management Group.⁵ At 4:09 pm the State Disaster Coordination Centre Australian Defence Force liaison officer, Major Ian Dunn, asked the Australian Defence Force Chief of Staff, Colonel Luke Foster, whether there was anything that Oakey Army Aviation Base could do to assist.⁶ Colonel Foster agreed to look into what support might be available. However, shortly after this, at 4:22 pm, Major Dunn advised Colonel Foster that helicopters with winches had been deployed by Queensland Fire and Rescue Service, and that no further assistance was required at that time but asked that the Oakey Army Aviation Base be put on notice that further assistance might be needed the next day.
5. The recordings of the telephone discussions over approximately the following two hours between Major Dunn and Colonel Foster capture the growing understanding by the State Disaster Coordination Centre of the afternoon's events in the Lockyer Valley. At 5:07 pm, there was a brief discussion in which Major Dunn said that the police needed helicopter support as fog was preventing aircraft flying out of Toowoomba. Colonel Foster suggested that the Blackhawks at Oakey Army Aviation Base could be called out however they are on 24 hours' notice to move. There was discussion about weather conditions and capability and Colonel Foster told Major Dunn that if he needed him to do any work to get the Blackhawks from Oakey Army Aviation Base ready to let him know. Major Dunn advised Colonel Foster that he did not think there was an issue at the moment.
6. At 6:20 pm, Major Dunn made a request for the Blackhawk helicopters to be used to transport a Special Emergency Response Team from the Police Academy at Oxley to Grantham, noting that it could take up to four hours for a

helicopter to be operational. However, shortly afterwards, the Australian Defence Force advised that cloud and storm conditions prevented helicopters flying from Oakey over the Toowoomba range that evening.

7. The Australian Defence Force provided two Sea King and two Blackhawk helicopters in the early morning of 11 January 2011.⁷
8. There is no evidence to suggest that either the District Disaster Management Group or the State Disaster Coordination Centre refused the assistance of Australian Defence Force helicopter support, and where Australian Defence Force helicopter support was considered it was in relation to police support activities rather than rescue or evacuation.
9. Further, there is no evidence to suggest that the rescue efforts in Grantham were in any way compromised by the absence of the Blackhawk helicopters, which would have taken a number of hours to deploy. In practice, five helicopters were deployed to the Lockyer Valley by the State very quickly on the afternoon of 10 January 2011. Four of those helicopters performed search and rescue missions in Grantham, with the first rescue taking place at about 5 pm on 10 January 2011.⁸

The claim there were more missing and deceased people than were reported to the State Coroner

10. In his statement to the Queensland Police Service dated 20 January 2011, Mr Martin Warburton stated that while he was sitting on the roof of his service station he saw two bodies swept past in the flow. He further stated that he saw two motor vehicles with a man and woman on the roof, and a second motor vehicle with a man on the roof, none of whom he had seen in town before, float by and disappear.⁹ He gave similar oral evidence to the Commission on 24 July 2015.¹⁰ This evidence, and the number of damaged and abandoned motor vehicles located in the Grantham area immediately following the 10 January 2011 flood, gave rise to concerns in the community that there may have been more missing and deceased people than were reported to the State Coroner.
11. The investigation into the deaths in the Toowoomba, Lockyer Valley and Ipswich regions was conducted by the Queensland Police Service for the State Coroner under the auspices of Taskforce Galaxy. The scope and conduct of the Taskforce's work is discussed in more detail in Chapter 6.
12. The search for missing persons and the recovery of deceased persons was led by Superintendent Mark Kelly of the Queensland Police Service. The Queensland Police Service, State Emergency Service, civilian contractors and the military undertook a painstaking search from Spring Bluff in Toowoomba to the Brisbane River – an area comprising 660 square kilometres including 131 kilometres of creek line.¹¹ In many cases locations were searched multiple times.
13. Detective Inspector David Isherwood gave evidence about the process adopted in the recovery, search and management of the 767 motor vehicles located between Toowoomba and the Lockyer Valley, of which 162 were located in the Grantham area.¹² This included inspecting every vehicle or contacting the owners.
14. Detective Inspector Isherwood also gave evidence about the governance surrounding the management and investigation of the 572 reported missing persons.¹³ Every report was followed up and, in all but the 25 deaths which were considered by the State Coroner¹⁴, every person was located. Significant local, national and international media coverage means that it is very unlikely that there were any unreported missing persons who were living in or transiting the Toowoomba, Lockyer Valley or Ipswich areas during the 2011 flood event.

15. There is no evidence to suggest there were any additional missing or deceased people than were reported to the State Coroner.

Allegations about property damage caused during searches of Grantham after 10 January 2011

16. Some residents were concerned there may have been unnecessary damage to properties in Grantham when they were being searched after 10 January 2011¹⁵.
17. Superintendent Mark Kelly of the Queensland Police Service described the search effort in Grantham, noting there were 46 people missing when the search was commenced on 12 January 2011 and, at that time, it was still hoped survivors would be found¹⁶. There were at least six residences in Harris Street from which people had been reported missing.¹⁷
18. There was a large amount of debris, vegetation and mud in the area which made the search of the residences difficult.¹⁸ Superintendent Kelly acknowledged that some property, including cars and irrigation equipment, was damaged during the search effort because of the use of excavators.¹⁹ However, it was necessary to lift and move wrecked vehicles due to the possibility of someone being trapped underneath them.²⁰ At that time, understandably, concerns about property damage were secondary.
19. Some residents claimed and received a payment under the *Disaster Management Act 2003*, which provides for compensation for loss or damage to property as a result of police or other emergency personnel exercising their disaster management powers.²¹²²

The claim that on the day of the flood 000 received a call warning about a wall of water heading to Grantham but that it was disregarded by the State Disaster Coordination Centre

20. Mr Jones noted in his statement²³ that he had been made aware that “*in social media one of the people involved in the 000 call centre with the ambulance service...had made comment that he received a call regarding a wave of water heading towards Grantham and reported this. At some time later he had received a call back from the State Disaster Coordination Centre to say there was nothing to be concerned about*”. This issue was also canvassed in his oral evidence at the hearings.²⁴ Mr Jones expressed the view that, although he did not accept the on-line post as fact, it was necessary for the Commission to scrutinise the matter given its apparently disturbing contents for the people of Grantham.²⁵ Ultimately, after being taken through the material, Mr Jones accepted that the allegation was untrue.²⁶
21. The comment was posted by “Richard” (no surname) to the on-line comments section appearing at the end of a newspaper article in *The Weekend Australian* about the findings of a review of the 2011 SKM report into the impact of the Grantham quarry on the flooding of Grantham. A screen-shot of the comment was provided to the Commission.²⁷
22. “Richard” self-identified as an emergency medical dispatcher on duty on the day of the flood and claimed that information he received in the course of his work at the emergency control centre about ‘*a dam wall being breached and a wall of water heading for Grantham*’ was disregarded by authorities.

23. There is no evidence that such a call to 000 was ever made. All 000 telephone services are recorded and then digitally archived. Queensland Health searched every channel recorded over the 24 hour period from midnight 10 January 2011 to midnight 11 January 2011 and nothing was identified that resembled the claim made by "Richard".²⁸
24. Queensland Health also undertook a review of rosters, timesheets and attendance records in an attempt to identify if the author "Richard" was working in the centre at the time. The records show that an emergency medical dispatcher by the name of Richard ended his shift at the centre at 6:30 am on 10 January 2011 but there was no-one of that name working in the centre at the time of the alleged call.
25. There is no evidence that there is any substance to the on-line comment by "Richard".

The timing of the State Emergency Service response to flooding in Grantham on 10 January 2011

26. In an affidavit dated 6 August 2015 and in oral testimony to this Commission, Ms Lisa Spierling raised concerns about the reported timing of the local State Emergency Service response to the flooding emergency in Grantham on 10 January 2011, and the significance the acceptance of that timing had on the evidence of residents about the flooding of the township.²⁹
27. In her statement to the Queensland Floods Commission of Inquiry dated 2 December 2011, State Emergency Service member Ms Annette Fifoot stated she received a telephone call from her group leader at 2:40 pm, and as a result of that call she attended the Gatton State Emergency Service headquarters at 2:50 pm to assist in warning the residents of Grantham of the flooding.³⁰ Her recollection of the timing was based on the Gatton State Emergency Service attendance logs. This Commission obtained copies of those logs,³¹ and Ms Fifoot's telephone records for 10 January 2011,³² and established the call from the group leader was in fact made to Ms Fifoot at 3:51 pm.
28. In her oral evidence to the Commission on 4 August 2015, Ms Fifoot accepted the time recorded in the attendance log was incorrect, having regard to her phone records and the five to ten minutes travel time from her home to the Gatton State Emergency Service headquarters.³³
29. The revised estimated time of arrival at the Gatton State Emergency Service headquarters of about 4 pm on 10 January 2011, and her observations of flooding in the Grantham area thereafter, is consistent with the observations of other witnesses and the flood modelling.

The claim about removal of Acting Senior Sergeant Bernie Wilce from the Local Disaster Management Group immediately after the floods

30. A further matter of concern to Mr Jones was the removal of Acting Senior Sergeant Bernie Wilce from his role as the police liaison officer with the Local Disaster Management Group on 13 January 2011, apparently due to Mr Wilce being "too close to Council". Mr Jones accepted this was not in fact the reason that Mr Wilce was removed.³⁴ However, Mr Jones did not know, at the time, the reason Mr Wilce had been replaced, although others in the Lockyer Valley Regional Council may have known the reason.³⁵ Mr Jones considered the replacing of Mr Wilce on the Local Disaster Management Group added an additional difficulty to communications with other agencies because while Mr Wilce's replacement was very co-operative he did not have Mr Wilce's local knowledge.³⁶
31. Mr Wilce, now a retired police officer, was relieving in the position of Acting Senior Sergeant and Acting Officer in Charge of the Gatton Police Station as at 10 January 2011. Mr Wilce was also a police liaison officer with the Local Disaster Management Group, a role he had held for a number of years.³⁷ In this role, he was heavily involved in the

emergency response to the flood event of 10 January 2011. On 13 January 2011, Senior Sergeant Stahlhut replaced Mr Wilce as police liaison officer for the Local Disaster Management Group.³⁸

32. Inspector Michael Curtin of the Queensland Police Service and Mr Wilce gave evidence to the Commission that Mr Wilce was replaced in his role as police liaison to the Local Disaster Management Group to allow him to focus on his duties as Officer in Charge and to ensure the continued performance of core police duties and services to the Gatton community during the disaster event.³⁹ This appears to be a reasonable and responsible decision, given the extraordinary demands on Mr Wilce and the rapidly mounting tasks at the Gatton Police Station⁴⁰ that arose during the 10 January 2011 disaster and continued for some time thereafter. There is no evidence that Mr Wilce was replaced for any other reason.

- ¹ Exhibit 96, Statement of Stephen Jones, 30 June 2015 [p2: paras 8-9]; Transcript 5 August 2015: Stephen Jones [p932: line 13 - p938: line 15].
- ² Transcript 6 August 2015: Jones [p940 line 24 – p951 line 32]; p997 line 42 – p995 line 5]
- ³ Exhibit 133, Statement of Air Vice-Marshal Kevin John Paule 10.05.2011 [paragraphs 14-28]
- ⁴ Exhibit 133, Statement of Air Vice-Marshal Kevin Paule, 10 May 2011 [p4: paras 14-28]; Exhibit 73, Affidavit of Acting Chief Superintendent Brett Schafferius, 23 July 2015 [p2: para 7].
- ⁵ Exhibit 273, Affidavit of Steven Dunn, 14 August 2015 [p3: para 5]; Exhibit 309, Audio recording of telephone communication between Major Ian Dunn, Australian Defence Force Liaison Officer in the State Disaster Coordination Centre and Colonel Luke Foster, Australian Defence Force Chief of Staff, 10 January 2011.
- ⁶ Exhibit 309, Audio recording of telephone communication between Major Ian Dunn, Australian Defence Force Liaison Officer in the State Disaster Coordination Centre and Colonel Luke Foster, Australian Defence Force Chief of Staff 10 January 2011.
- ⁷ Exhibit 133, Statement of Air Vice-Marshal Kevin Paule, 10 May 2011 [p10: para 66]; Exhibit 73, Affidavit of Acting Chief Superintendent Brett Schafferius, 23 July 2015 [p3: para 10].
- ⁸ Exhibit 290, Statement of Commissioner Lee Johnson, 12 December 2011 [Attachment LAJ-7: Statement of John McDermott 6 April 2011]; Exhibit 284, Statement of Stuart Wark, 5 March 2011; Exhibit 285, Statement of David Turnbull, 1 April 2011; Exhibit 286, Statement of Benjamin Sutherland 9 March 2011; Exhibit 287, Statement of Daren Parsons, 14 February 2011; Exhibit 217, Statement of Mark Kempton 17 February 2011.
- ⁹ Exhibit 38, Statement of Martin Warburton, 20 January 2011 [pp12-13: paras 76-80 and pp 14-15: para 82-90].
- ¹⁰ Transcript 24 July 2015: Martin Warburton [p390: line 4 - p391: line 3].
- ¹¹ Exhibit 89, Statement of Superintendent Mark Kelly, 10 July 2015 [p2: para5]; Transcript 4 August 2015: Superintendent Mark Kelly [p830: lines 12-19].
- ¹² Transcript 4 August 2015: Detective Inspector David Isherwood [p762: line 32-p764: line 17]; Exhibit 82, Two spreadsheets of vehicles located by the Queensland Police Service.
- ¹³ Transcript 4 August 2015: Detective Inspector David Isherwood [p760: line 18 - p762: line 30]; Exhibit 81, Three spreadsheets of missing persons and deceased.
- ¹⁴ Coronial Inquest, Office of the State Coroner: *Inquest into the deaths caused by the south-east Queensland floods of January 2011*, 5 June 2012.
- ¹⁵ Transcript 23 July 2015: Raymond Van Dijk [p363: lines 10-26]; Exhibit 259, Affidavit of Raymond Van Dijk, 29 July 2015 [p1: para 4].
- ¹⁶ Transcript 4 August 2015: Superintendent Mark Kelly [p842: lines 1 - 21]; Exhibit 89, Statement of Superintendent Mark Kelly, 10 July 2015 [Attachment: Statement of Superintendent Mark Kelly, 24 May 2011, p3].
- ¹⁷ Exhibit 89, Statement of Superintendent Mark Kelly, 10 July 2015 [Attachment: Statement of Superintendent Mark Kelly, 24 May 2011, p3].
- ¹⁸ Exhibit 89, Statement of Superintendent Mark Kelly, 10 July 2015 [Attachment: Statement of Superintendent Mark Kelly, 24 May 2011, p3].
- ¹⁹ Transcript 4 August 2015: Superintendent Mark Kelly [p841: lines 37-45].
- ²⁰ Transcript 4 August 2015: Superintendent Mark Kelly [p842: lines 9-13].
- ²¹ Part 11, *Disaster Management Act 2003*.
- ²² Transcript 4 August 2015: Superintendent Mark Kelly [p842: lines 29-35].
- ²³ Exhibit 96, Statement of Stephen Jones, 30 June 2015 [p2: para 6].
- ²⁴ Transcript 5 August 2015: Stephen Jones [p930: line 35 – p932: line 10].
- ²⁵ Transcript 5 August 2015: Stephen Jones [p931: lines 37 – 41].
- ²⁶ Transcript 6 August 2015: Stephen Jones [p946: lines13-19] .
- ²⁷ Exhibit 124, Comment by Richard on The Australian website.
- ²⁸ Exhibit 126, Response to notice to produce from Queensland Health, 22 June 2015.
- ²⁹ Exhibit 138, Affidavit of Lisa Spierling, 6 August 2015 [p2: para 6]; Transcript 7 August 2015: Lisa Spierling [p1063: line 27 - p1064: line 42].
- ³⁰ Exhibit 85, Statement of Annette Fifoot, 2 December 2011 [p1: paras 2-3].
- ³¹ Exhibit 276, Affidavit of Acting Assistant Commissioner Peter Jeffrey, 29 July 2015 [Attachment PRJ-4].
- ³² Exhibit 293, Telephone records of Annette Fifoot.
- ³³ Transcript 4 August 2015: Annette Fifoot [p816, line 4 - p819 line24].
- ³⁴ Transcript 5 August 2015: Stephen Jones [p926: line 42 – p927: line 1].
- ³⁵ Transcript 5 August 2015: Stephen Jones [p923: lines 40 – 44].
- ³⁶ Exhibit 96, Statement of Stephen Jones, 30 June 2015 [p2: para 5; pp3-4: para 15]; Transcript 5 August 2015: Stephen Jones [p922: line 24 – p923: line 35].
- ³⁷ Exhibit 92, Affidavit of Bernard Wilce, 23 July 2015 [p2: para 4].
- ³⁸ Exhibit 92, Affidavit of Bernard Wilce, 23 July 2015 [p17: para 91]; Exhibit 188, Affidavit of Inspector Michael Curtin 17 July 2015 [p2: para 8].
- ³⁹ Exhibit 92, Affidavit of Bernard Wilce, 23 July 2015 [pp17-18: paras 91-95]; Exhibit 188, Affidavit of Inspector Michael Curtin 17 July 2015 [pp2-3: para 8]; Transcript 5 August 2015: Bernard Wilce [p856: line 36 - p857: line 14].
- ⁴⁰ Transcript 5 August 2015: Bernard Wilce [p856: lines 31-34; p857: lines 11-14].

Appendix F: Terms of Reference

Commissions of Inquiry Order (No. 3) 2015

Short title

1. This Order in Council may be cited as the Commissions of Inquiry Order (No. 3) 2015.

Commencement

2. This Order in Council commences on 11 May 2015.

Appointment of Commission

3. UNDER the provisions of the Commissions of Inquiry Act 1950 the Governor in Council hereby appoints Walter Sofronoff QC, from 11 May 2015, to make full and careful inquiry in an open and independent manner with respect to the following matters, but not so as to include a review or investigation of the way in which the Queensland Floods Commission of Inquiry was conducted:
 - a) the flooding of the Lockyer Creek between Helidon and Grantham on 10 January 2011, with specific reference to any natural or man-made features of the landscape which could have altered or contributed to the flooding;
 - b) whether the existence or breach of the Grantham quarry caused or contributed to the flooding of Grantham;
 - c) whether the existence or breach of the Grantham quarry had a material impact on the damage caused by the flooding at Grantham;
 - d) whether the breach of the Grantham quarry had implications for evacuation of Grantham;
 - e) how these matters were first investigated and how eyewitness accounts were dealt with, particularly by State Government agencies and Emergency Services.
4. AND directs that the Commission carry out its inquiry by calling on expert hydrologists, expert engineers, law enforcement, emergency services and relevant industry; and reviewing relevant literature and data.
5. AND further directs that, in carrying out the inquiry the Commission may have regard to the experiences of individuals and other entities directly or indirectly affected by the flooding of the Lockyer Creek between Helidon and Grantham on 10 January 2011 to the extent the Commissioner considers relevant.
6. AND further directs that the Commission is to have regard to any reports, evidence, data, eyewitness accounts and video footage, in relation to the flooding of the Lockyer Creek between Helidon and Grantham on 10 January 2011, including the findings of the Queensland Floods Commission of Inquiry.

Commission to report

7. AND directs that the Commissioner make full and faithful report and recommendations which he considers appropriate on the aforesaid subject matter of inquiry, and transmit the same to the Honourable the Premier and Minister for the Arts by 31 August 2015.

Report to be made public

8. AND further directs that the Report transmitted to the Honourable the Premier and Minister for the Arts be made public upon its transmission to the Honourable the Premier and Minister for the Arts.

Application of Act

9. THE provisions of the Commissions of Inquiry Act 1950 shall be applicable for the purposes of this inquiry, except for section 19C (Authority to use listening devices).

Conduct of Inquiry

10. THE Commissioner may hold hearings in such a manner and in such locations as may be necessary and convenient.

Endnotes

1. Made by the Governor in Council on 7 May 2015.
2. Notified in the Gazette on 8 May 2015.
3. Not required to be laid before the Legislative Assembly.
4. The administering agency is the Department of the Premier and Cabinet.

-
1. On 3 September, the Governor in Council extended the reporting time to 30 September 2015 and on 24 September a further one week extension was made requiring the Commissioner to report by 7 October 2015.

Appendix G: Specific findings with respect to the Terms of Reference

- a) **The flooding of the Lockyer Creek between Helidon and Grantham on 10 January 2011, with specific reference to any natural or man-made features of the landscape which could have altered or contributed to the flooding.**

The flooding of the Lockyer Creek between Helidon and Grantham on 10 January 2011 was the product of the combination of a rare rainfall event that caused a rapid and significant rise in the Lockyer Creek and the natural topography of that part of the Lockyer Valley. The flooding of Grantham was not caused by either the Grantham quarry, or the Grantham sand plant taken as a whole, or the railway line that passed through Grantham. Each of the Grantham quarry and the railway line had an effect, but not a material effect on the flooding of Grantham. The most likely effect of the Grantham quarry was to delay the flooding of Grantham for an insignificant period of up to a very few minutes. The most likely effect of the railway line was to cause a slight increase in the depth and intensity of the flooding but in circumstances where the flooding would, in any event, have been extremely hazardous.

- b) **Whether the existence or breach of the Grantham quarry caused or contributed to the flooding of Grantham.**

Neither the existence nor breach of the Grantham quarry caused the flooding of Grantham. The pit that formed part of the Grantham quarry delayed the flooding of Grantham by no more than an insignificant few minutes.

- c) **Whether the existence or breach of the Grantham quarry had a material impact on the damage caused by the flooding at Grantham.**

Neither the existence nor breach of the Grantham quarry had any material impact on the damage caused by the flooding at Grantham.

- d) **Whether the breach of the Grantham quarry had implications for evacuation of Grantham.**

The breach of the Grantham quarry did not have implications for the evacuation of Grantham.

- e) **How these matters were first investigated and how eye witness accounts were dealt with, particularly by State Government Agencies and Emergency Services.**

The investigation by police was conducted in accordance with the appropriate protocols and procedures. It was thorough, professional and was carried out as well as it could have been in difficult circumstances.

Appendix H: Expert reports

The Commission engaged a number of experts to investigate and report on specific aspects of the 2011 flood in Grantham. These experts and the reports they produced for the Commission are listed below.

Dr John Macintosh, Water Solutions Pty Ltd

- Expert hydrology report 10 January 2011 flood—circumstances and contributing factors, 17 August 2015
- Expert hydrology report 10 January 2011—flood circumstances and contributing factors supplementary material, 17 August 2015
- Expert hydrology report 10 January 2011—flood circumstances and contributing factors supplementary material no. 2, 3 September 2015

Mr David Starr, Golder Associates Pty Ltd

- Geotechnical investigations and expert opinion on formation of earthworks, 28 August 2015
- Geotechnical investigations and expert opinion on formation of earthworks - supplementary report concerning location of failed power pole P182127, 28 August 2015
- Geotechnical investigations and expert opinion on formation of earthworks - supplementary report concerning pre-quarry terrain at sand batching plant, 2 September 2015

Mr Stefan Szyrkarski, DHI Water and Environment Pty Ltd

- Review of expert hydrology report 10th January 2011 Grantham flood, 13 August 2015

Mr Colin MacKenzie, MacKenzie Consulting

- Investigation of timber utility pole failure, 4 August 2015

Mr Grantley Smith, Water Research Laboratory, UNSW

- Expert opinion: Stability of people, vehicles and buildings in flood water, 13 August 2015

Copies of these reports are available for download from the Commission website at www.granthaminquiry.qld.gov.au.

Appendix I: Parties granted leave to appear

Party	Represented by	Instructed by	Terms of Reference
The State of Queensland	Mr J Rolls	Crown Law	3(d), 3(e)
Lockyer Valley Regional Council	Mr K Wilson QC	Australian Property Lawyers	3(a), 3(b), 3(c), 3(d), 3(e)
Wagners Pty Ltd	Mr P Davis QC Mr N Andreatidis	Wotton+Kearney	3(a), 3(b), 3(c), 3(d)
Ms Elizabeth Fraser, Mr Daniel McGuire, Mr Chris Barrett, Mr Kenley Arndt, Ms Frances Arndt, Mr Martin Warburton, Mr Wayne Lack, Ms Christine Lack, Mr Daniel Brian, Ms Sharon Watkins, Ms Lisa Spierling, Mr Raymond Van Dijk, Mr Christopher Short, Ms Sabina Short, Ms Janelle Warburton, Ms Gilda Tate, Ms Bronwen Baxter.	Mr S Holt QC Mr B Power	Boe Williams Anderson	3(a), 3(b), 3(c), 3(d), 3(e)
Ms Sheryl McMullen, Mr David McMullen, Mr John (Sean) Gillespie, Mr John Gallagher, Ms Noreen Gallagher, Mr Tom Friend, Ms Sandra Friend, Mr Jonathan Sippel, Mr Wayne Sippel, Ms Dell Sippel, Mr Peter Kuhle.	Mr T Tobin SC	Maddens Lawyers	3(a), 3(b), 3(c)
Queensland Rail	Ms J Brien	Clayton Utz	3(a)

Appendix J: Exhibits, witnesses, public submissions and statements

Exhibits

During the course of the inquiry 309 exhibits were tendered as evidence to be considered by the Commissioner.

The exhibits are available via the Commission website at www.granthaminquiry.qld.gov.au.

Witness appearances

A total of 41 witnesses gave evidence during the public hearings, including five expert witnesses and 21 eyewitnesses.

Frances Arndt	Kathleen Mahon
Kenley Arndt	Allan Marshall
Helen Besley	Daniel McGuire
Athol Fowler	Anthony McIntosh
Annette Fifoot	Plain Clothes Constable Hayley Munro
Ian Flint	Ian Pinkerton
Thomas Friend	Lance Richardson
Patrick John Gallagher	Jonathan Sippel
John (Sean) Gillespie	Grantley Smith
Senior Constable Debbie Haworth	Lisa Spierling
Dean Heit	John Stark
Detective Inspector David Isherwood	David Starr
John Johnson	Henry Stephenson
Counsellor Stephen Jones	Stefan Szykarski
Superintendent Mark Kelly	Raymond Van Dijk
Francis King	Denis Wagner
Christine Lack	Martin Warburton
Wayne Lack	Robert Ward
Trevor Leishman	Sharon Watkins
Dr John Macintosh	Bernard Wilce
Colin MacKenzie	

Public Submissions

A total of 32 individuals made submissions to the Commission which are published on the Commission website at www.granthaminquiry.qld.gov.au.

Submissions were not published where they were provided in confidence, subject to the copyright of another party, obscene or potentially defamatory.

Robert Bowyer	Daniel McGuire
Lee-Ann Crowley	David Pascoe
Stuart Damrow	Kenneth Pearce
Robert French	Brendan Pendergast
Patrick John Gallagher	Neil Pennell
Jim C Galletly	Katherine Plint
Ian Garrard	Greg Rogencamp
Amanda Gearing	Gary Smith
John (Sean) Gillespie	Lisa Spierling
Graeme Harrison	Lynette Rashleigh Thompson
Patrick Hill (Jacobs)	John Tyson
John V Hodgkinson	Wagners
John	Gary Webb
Neville Jones	Max Winders
Nadesu Kailainathan	Graham Wode
Haydn Kelly	Name withheld
Ian McEwan	

Statements

A total of 101 people provided statements or affidavits to the Grantham Floods Commission of Inquiry.

Kelvin Anderson Public Safety Business Agency	Counsellor Stephen Jones Lockyer Valley Regional Council
Frances Arndt	Dr Phillip Jordan
Kenley Arndt	Superintendent Mark Kelly Queensland Police Service
Ronald Barbagallo Energex Limited	Francis King
Leanne Barbeler Department of Natural Resources and Mines	Christine Lack
Wilma Baukema	Wayne Lack
Fiona Beatty Lockyer Valley Regional Council	Trevor Leishman
Graham Besley	John Mahon
Helen Besley	Kathleen Mahon
Jon Black Department of Environment and Heritage Protection	Charmaine Mallon
Scott Blanchard Department of Environment and Heritage Protection	Neville Mallon
Shane Brennan Queensland Health	Allan Marshall
Kara Lee Butler Wotton + Kearney	Detective Inspector Andrew Massingham Queensland Police Service
Mark Campbell Holcim (Australia) Pty Ltd	Daniel McGuire
Katarina Carroll Queensland Fire and Emergency Services	Anthony McIntosh
Harry Castle	Andrew McLoughlin
Miriam Cathcart Department of Natural Resources and Mines	Wallace Morris
Cameron Coleman	Plain Clothes Constable Hayley Munro Queensland Police Service
Raisa Conchin Wotton + Kearney	Nicole Naylor Department of Environment and Heritage Protection
Andrew Connor Department of Environment and Heritage Protection	Phillip Neumann

Richard Cork	Susan Nightingale Department of Infrastructure, Local Government and Planning
Margaret Cover	Ian Pinkerton
Janet Crust	John Price Energex
Michael Curtin Queensland Police Service	Lance Richardson
Stuart Damrow	Neil Robertson
Assistant Commissioner Alistair Dawson Queensland Police Service	Gerard Ross
Gwendolene Drury	Sue Ryan Department of Natural Resources and Mines
Nicholas Duff	Acting Chief Superintendent Brett Schafferius
Steven Dunn Queensland Fire and Emergency Services	Jamie Simmonds Lockyer Valley Regional Council
Ian Flint Lockyer Valley Regional Council	Annaka Sippel
Athol Fowler	Darryl Sippel
Andrea Foyle	Jonathan Sippel
Major General John Frewen Department of Defence	Lisa Spierling
Thomas Friend	John Stark
James Friis	Troy Steffens
John Gallagher	Henry (Bob) Stephenson
John Gillespie	Gilda Tate
Deputy Commissioner Stephan Gollschewski Queensland Police Service	Peter Todd Department of Natural Resources and Mines
Phillip Gregory	Raymond Van Dijk
Daniel Harris Department of Energy and Water Supply	Marie Van Straten
Senior Constable Debbie Haworth Queensland Police Service	Denis Wagner Wagners
Dean Heit	Martin Warburton
Caroline Helman Department of the Premier and Cabinet	Robert Ward Nine Network
Detective Inspector David Isherwood Queensland Police Service	Sharon Watkins

Zelda Jamieson	Acting Superintendent Mark Wheeler Queensland Police Service
Peter Jeffrey Queensland Fire and Emergency Services	Stephen Whitehouse
Simon Jeffery Boral Resources Qld Pty Ltd	Bernard Wilce
Stanley Jibson	Nathan Williamson Queensland Ambulance Service
John Johnson	Inspector Bradley Wright Queensland Police Service
Stephen Johnston Department of Infrastructure, Local Government and Planning	Gavin Zischke
Simon Johnstone	

Appendix K: Commission staff

Commissioner

Walter Sofronoff QC

Counsel Assisting

Michael Hodge

Junior Counsel

Julia O'Connor

The Commissioner and counsel assisting the Commission were supported in their roles by Commission staff who were drawn from a range of professions.

Name	Position
Sally Badcock	Principal Project Officer
Rachel Barley	Principal Project Officer
Louise Burke	Senior Administration Officer
Kate Dodgson	Legal Officer
Shaun Goodwin	Communications Officer
Timea Havas	Legal Officer
Travis Jones	Hearings Officer
Christopher Jory	Detective Inspector
Andrew Kennedy	Detective Senior Sergeant
Ben Osborne	Records Management Officer
Joanne Paterson	Director
Eryn Voevodin	Principal Project Officer

Appendix L: Glossary of terms

Term	Description
Australian Height Datum (AHD)	A level datum, uniform throughout Australia, based on an origin determined from observations of mean sea level at tide gauge stations, located at more than 30 points along the Australian coastline.
Bank	The natural side of the creek, rising from the creek bed to the edge of the flood plain (see embankment).
Bund	A man-made mound of earth or other natural material, which may form a barrier to the flow of water.
Breach	An opening or hole created through a barrier. In a flood event, the overtopping of a bund will usually lead to erosion of the bund and possibly the natural terrain beneath.
Catchment	That area determined by topographical or equivalent features, upon any part of which rain falling will contribute to the discharge of the stream at the point under consideration.
Central Grantham	That area within the township of Grantham close to Sandy Creek, between the railway embankment to the north, the Gatton-Helidon Road to the south between around 1332 Gatton-Helidon Road to the west and 12 Anzac Avenue to the east.
Commission	The Grantham Floods Commission of Inquiry. The Commission was established on 11 May 2015 to make full and careful inquiry into the flooding of the Lockyer Creek between Helidon and Grantham on 10 January 2011, with specific reference to any natural or man-made features of the landscape which could have altered or contributed to the flooding.
Commissioner	The Commissioner of the Grantham Floods Commission of Inquiry.
Conductors	Overhead lines that conduct electricity.
Discharge	The rate of flow of water measured in terms of volume per unit time, for example, cubic metres per second (m ³ /s).
Eastern bund	The earthen bund running on the pit side of the access track on the embankment that separates the Grantham quarry pit from Lockyer Creek on the western side of the pit.
Eastern Grantham	That area within the township of Grantham to the east of Sandy Creek and bounded by the railway embankment to the north and Gatton-Helidon Road to the south.
Embankments	The features lying between the Lockyer Creek bank and the quarry pit on three sides of the quarry pit, each roughly trapezoid in cross section, with one side being the creek bank and the other side being the side of the pit. Bunds and stockpiles are or were located on top of the embankments. (see also bank).

Flash flooding	Flooding which is sudden and unexpected. It is often caused by sudden local or nearby heavy rainfall. Often defined as flooding which peaks within six hours of the causative rain.
Flood	Water inundating land that is normally dry.
Floodplain	The relatively flat area adjoining the channel of a natural stream which has been or may be inundated with floodwaters.
Flood storage areas	Those parts of the floodplain that are important for the temporary storage of floodwaters during the passage of a flood. The extent and behaviour of flood storage areas may change with flood severity, and loss of flood storage can increase the severity of flood impacts by reducing natural flood attenuation. The floodplain areas adjacent the main channel of a river or creek usually provides storage capacity.
GFCOI model	Hydraulic model developed for the purposes of the Grantham Floods Commission of Inquiry.
Grantham quarry	The part of the Grantham sand plant that is located on Lot 2 RP 142079 and Lot 103 CH31505. It comprises the quarry pit, bunds and other surface disturbances such as spoil piles, stockpiles and tracks associated with the quarry operations.
Grantham sand plant	Located at Quarry Access Road, Grantham. It comprises the Grantham quarry and the plant area located over three lots (Lot 3 RP 157143, Lot 2 RP 142079 and Lot 103 CH31505).
Hydraulics	The study of water flow in waterways, in particular the evaluation of flow parameters such as water level and velocity.
Hydraulic roughness	Refers to a hydraulic parameter used by a computer simulation hydraulic modelling program that represents the roughness of the surface over which the modelled water is to flow. The greater the roughness the slower and deeper the water flows (see also Manning's n).
Hydrograph	A graph that shows how the discharge or flood level at any particular location varies with time during a flood.
Hydrology	The study of rainfall and runoff processes, in particular the evaluation of peak flows, flow volumes and the derivation of hydrographs for a range of floods.
Intensity	A measure of the force of flood waters, being the velocity multiplied by the depth of the water, for example, metres squared per second (m ² /s).
LiDAR	The measurement of the ground surface using a device usually mounted in a plane or helicopter. The device is used to measure surface levels by measuring the time it takes for a light beam to return to the device after bouncing off the surface below. The method produces high density data points that must be carefully processed to filter out erroneous readings and the effects of vegetation (e.g. trees, grass). LiDAR cannot penetrate water and will therefore pick up only the surface level of a water body (e.g. dam or lake surface).
LVRC models	Hydrology and hydraulic models used by Lockyer Valley Regional Council for floodplain management and planning purposes.
Macintosh first supplementary report	Dr John Macintosh, Report to Grantham Floods Commission of Inquiry – Expert Hydrology Report 10 January 2011 – Circumstances and Contributing Factors –

	Supplementary Report, 11 August 2015
Macintosh main report	Dr John Macintosh, Report to Grantham Floods Commission of Inquiry – Expert Hydrology Report 10 January 2011 – Circumstances and Contributing Factors, 11 August 2015.
Macintosh second supplementary report	Dr John Macintosh, Report to Grantham Floods Commission of Inquiry – Expert Hydrology Report 10 January 2011 – Circumstances and Contributing Factors Supplementary Material No. 2, 3 September 2015.
Main breach	The scour channel that developed towards the northern end of the western embankment of the Grantham quarry.
Manning's n	A standard parameter used to quantify hydraulic roughness. The higher the value for Manning's n, the rougher the surface, and the slower and deeper the water flows (see also hydraulic roughness).
Newton main report	Dr David Newton, Impact of the Grantham Sand Quarry on the January 2011 Flood in Grantham, 3 July 2015.
Newton supplementary report	Dr David Newton, January 2011 flood in Grantham Supplementary Report 1, 17 August 2015.
Plant area	The part of the Grantham sand plant that is located on Lot 3 RP 157143, and containing the offices, weighbridge, concrete batching plant, bunded retention ponds and stockpiles. Together with the Grantham quarry it comprises the Grantham sand plant.
Quarry pit	The excavation in the Grantham quarry.
Queensland Floods Commission of Inquiry (QFCOI)	Commission of Inquiry established in 2011 to examine the 2010-11 floods in Queensland.
Rating curve	A relationship between flood level and flow rate at a gauging station, used to convert measured levels to estimated flow rates at the site.
Run time	The amount of time it takes to run a model. Run times for hydrology models usually are of the order of minutes, with complex two-dimensional hydraulic models potentially taking hours or days to run. In a hydraulic model, run time varies with a large number of modelling factors including grid size, extent of area modelled, number of wet cells, time step, duration of the event as well as the solution scheme used by the program and the capability of the computer used.
Runoff	The amount of rainfall which actually ends up as streamflow, also known as rainfall excess.
Slip failure	An engineering term referring to a mechanism by which an earth slope collapses through the action of an area of the slope sliding downwards on a plane of weakness. A slip failure is often characterised by the appearance of an exposed smooth face of material over which the failed slope has moved. Slip failures usually occur when the soil material has become saturated and loses strength, or when the toe of an earth embankment has been undermined by the eroding flow of water.

Starr first supplementary report	Mr David Starr, Grantham Quarry – Geotechnical investigations and expert opinion on formation of earthworks – Supplementary report concerning location of failed power pole P182127, revised 28 August 2015.
Starr main report	Mr David Starr, Grantham Quarry – Geotechnical investigations and expert opinion on formation of earthworks, revised 18 August 2015.
Starr second supplementary report	Mr David Starr, Grantham Quarry – Geotechnical investigations and expert opinion on formation of earthworks – Supplementary report concerning pre-quarry terrain at sand batching plant, 2 September 2015.
Stays	Diagonal braces (usually a multi strand metal cable) that attach to just below the cross arms near the top of a pole and run at an angle to an anchor point in the ground. The stays provide support to the top of a utility pole to counter-balance forces from conductors attached to the top of the pole.
Szylkarski August 2015 report	Mr Stefan Szylkarski, Review of Expert Hydrology Report – 10 January 2011 Flood, 13 August 2015.
Szylkarski February 2015 report	DHI Water & Environment Pty Ltd (Mr Stefan Szylkarski), Grantham and Wagner Quarry Review of Flood Impact 10 January 2011 event prepared for Nationwide News Pty Ltd, February 2015.
Taskforce Galaxy	The specially formed Queensland Police Service taskforce responsible for investigation, on behalf of the State Coroner, of the immediate loss of life through flooding and immediate cause of death as a result of the 2011 flood event.
Terms of Reference	The Terms of Reference of the Grantham Floods Commission of Inquiry are provided as Appendix F.
Water surface profile	A graph showing the flood water level at any given location along a watercourse at a particular time.
Western bund	The earthen bund running on the creek side of the access track on the embankment that separates the Grantham quarry pit from Lockyer Creek on the western side of the pit.
Western Grantham	That area within the township of Grantham to the west of Sandy Creek and bounded by the railway embankment to the north, Gatton-Helidon Road to the south and to/or around Armstrong’s Road to the east.

Nomenclature

Term	Description
2D	Two dimensional
AHD	Australian Height Datum
BOM	Bureau of Meteorology
GFCOI	Grantham Floods Commission of Inquiry
Jacobs	Jacobs Pty Ltd, formerly SKM Pty Ltd
LiDAR	Aerial survey using light detection and ranging
LVRC	Lockyer Valley Regional Council
m	Length in metres
m/s	Velocity in metres per second
m ² /s	Intensity in metres squared per second
m ³ /s	Discharge in cubic metres per second
mAHD	metres above Australian Height Datum
QFCOI	Queensland Floods Commission of Inquiry
RAFTS	A rainfall runoff hydrology model
SKM	Sinclair Knight Merz, now part of Jacobs
TUFLOW	A 2D hydraulic model